



## Programmable differential pressure transmitter SCC-P with auto zero function

The SCC-P is a programmable differential pressure transmitter. The transmitter measures the differential pressure using a ceramic sensor. The signal is temperature compensated and calibrated. An auto zero function ensures that the transmitter has no zero offset. It is performed by default after power-up and periodically once a day. The pressure is measured every 100 ms, giving a sampling frequency of 10 Hz. The number of samples for the averaging filter and the minimum and maximum pressure can be configured with parameters. The transmitter calculates the output signal for the analogue output accordingly.

### Features

- Measures air differential pressure
- Pressure measurement from  $\pm 100$  Pa up to  $\pm 2500$  Pa ( $\pm 10$  mm to  $\pm 250$ mm H<sub>2</sub>O,  $\pm 0.4$  to  $\pm 10$  in H<sub>2</sub>O)
- Integrated auto zeroing function using a solenoid valve
- DIP switch for pressure range pre-set
- Programmable pressure output signal range
- Selectable square root function
- Selectable averaging filter for the measurement signal
- Minimum and maximum pressure memory
- Set display range and value. This may be used to visualize air flow or air volume
- 0(2)...10 V / 0(4)...20 mA measuring signal output (range programmable)

### Applications

- Pressure measurement in the field of heating, ventilation and air conditioning
- Measuring of air flow velocity
- Measuring and control of positive or negative pressure for example for clean rooms
- Measure exactly the pressure range you need
- Recording of minimum and maximum values for critical environments
- Supervision of critical pressures

### Auto Zero

The Auto Zero function zeroes out any differential pressure that may be present in a system during normal operation. This allows the differential pressure in a system to be effectively measured.

- Auto Zero automatically calibrates the zero offset to 0 Pa.
- Auto Zero is performed on start-up.
- The auto-zero process may be repeated in an interval which is defined with IP09. The default setting for this interval is 24 hours. Setting IP09 to 0 will prevent automatic re-calibration.
- During the auto zero process, which takes approximately 5 seconds, the pressure reading and analogue output are frozen.

## Pressure range configuration

The measuring pressure range of the selected SCC-P type can be set with DIP switches or fine-tuned with configuration parameters.

### ▲ Pressure range configuration with DIP switch

The following pre-set pressure ranges can be selected with the DIP switches:

Number (DIP switch)	Pressure Range [Pa]	SCC-P Sensor Type		
		SCC-P2	SCC-P3	SCC-P4
0 <sup>1)</sup>	-100...100% <sup>2)</sup>	± 100 Pa	± 500 Pa	± 2500 Pa
1	0...100%	0...100 Pa	0...500 Pa	0...2500 Pa
2	0...40%	0...40 Pa	0...200 Pa	0...1000 Pa
3	-40...40%	± 40 Pa	± 200 Pa	± 1000 Pa
4	0...50%	0...50 Pa	0...250 Pa	0...1250 Pa
5	-50...50%	± 50 Pa	± 250 Pa	± 1250 Pa
6	0...60%	0...60 Pa	0...300 Pa	0...1500 Pa
7	-60...60%	± 60 Pa	± 300 Pa	± 1500 Pa

1) Standard position of DIP switch

2) Pressure range according to configuration parameter IP 03 and IP 04 (standard range -100%...100%)

For your convenience, use the DIP switches to select a pre-set pressure range. For details see section "Pressure range selection" on page 6.

### ▲ Pressure range fine tuning with configuration parameters

The pressure signal can be fine-tuned to suit your system. Define your signal by setting a minimum and maximum pressure limit. The output will only react when the pressure is above the lower limit. The output signal will span up to the upper limit. This allows the full resolution of the output signal to be used even if only a fraction of the pressure sensor's signal range is used. For example, a 0-300 Pa transmitter can be converted to a 0-100 Pa transmitter. (Note: this does not improve the sensor resolution, only the output signal resolution).

For details see section "Pressure range selection", page 6 and "Configuration Parameters", page 7.

## Minimum and maximum values

Using the optional built-in operation terminal "OPC-S V2" or the external operation terminal "OPA-S", the user has the possibility to read out and reset the minimum and maximum values. The minimum and maximum values can be sent to the output using parameter OP 00. In this way the sensor can be used to monitor pressure in critical environments. The minimum and maximum values are stored in the EEPROM every minute. They are available even after a power failure.

## Square root function

The input signal is multiplied by a square root function. This changes the signal curve to the typical square root shape. This is useful for direct measurement and control of air flows. The air flow is proportional to the square root of the differential pressure. The figure on the right shows the shape of the square root function.

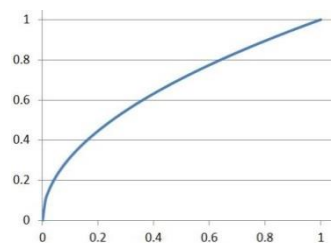

## Safety



### DANGER! Safety advice

This device is intended for use as an operational controller or sensor. It is not a safety device. Where failure of the equipment could endanger life and property, it is the responsibility of the customer, installer and system designer to provide additional safety devices to prevent such failure. Failure to comply with specifications and local regulations may result in damage to the equipment and endanger life and property. Tampering with the unit and misuse will void the warranty.

## Product Testing and Certification



Declaration of  
Conformity

Information on the conformity of our products can be found on our website [www.vectorcontrols.com](http://www.vectorcontrols.com) on the corresponding product page under "Downloads".

### Types and Ordering

Product Name	Product No.	Description / Function
SCC-P2	40-300246	Differential pressure sensor Pressure range $\pm 100$ Pa ( $\pm 10$ mm, 0.4 in H <sub>2</sub> O)
SCC-P3	40-300247	Differential pressure sensor Pressure range $\pm 500$ Pa ( $\pm 50$ mm, 2 in H <sub>2</sub> O)
SCC-P4	40-300248	Differential pressure sensor Pressure range $\pm 2.5$ kPa ( $\pm 250$ mm, 10 in H <sub>2</sub> O)

### Accessories

Product Name	Product No.	Description
<i>Built-in Operation Terminal</i>		
OPC-S	40-500029	Optional built-in operation terminal for SCC-P devices. Replaces housing cover
<i>External Operation Terminal</i>		
OPA-S	40-500006	External operation terminal, for configuration only
OPU-S	40-500030	External operation terminal (US version), for configuration only
<i>Probe</i>		
AMP-1	40-510087	Differential pressure probes with 0.5m tube $\varnothing$ 6mm

### Documentation overview

Document Type	Document No.	Description
SCC-P Data Sheet	70-00-1004	Product data sheet (this document)
SCC-P Install Sheet	70-00-0999	Mounting and installation instructions
OPA-S Operation Manual	70-00-0171	Operations instructions for external operation terminal OPA-S
OPU-S Short Instruction	70-00-0303	Short instructions for external operation terminal OPU-S (US version)

Note: The above list is not complete. The documents on the website are relevant.

## Technical specifications

<b>Power supply</b>	Power requirements	24 VAC ±10% 50/60 Hz, 24 VDC ±10%		
	Power consumption	Max. 2 VA		
	Safety extra low voltage (SELV)	HD 384, Class II		
	Electrical connection	Screw terminal for wire 0.32...2.0 mm <sup>2</sup> (AWG 22...14)		
<b>Signal inputs</b>	Product type	<b>SCC-P2</b>	<b>SCC-P3</b>	<b>SCC-P4</b>
	Static sensor type:	Ceramic	Ceramic	Ceramic
	Auto-zero-function	yes	yes	yes
	Pressure range	± 100 Pa (± 0.4 in H <sub>2</sub> O)	± 500 Pa (±2.0 in H <sub>2</sub> O)	± 2500 Pa (± 10 in H <sub>2</sub> O)
	Error band after zeroing	< 1 % FSS	< 2 %FSS	< 1 %FSS
	Proof pressure (overload pressure)	7 kPa (1.0 psi)	14 kPa (2 psi)	14 kPa (2 psi)
	Burst pressure	20 kPa (2.9 psi)	70 kPa (10 psi)	70 kPa (10 psi)
<b>Signal outputs</b>	Output signal	Analog output for differential pressure signal 0/2...10 VDC or 0/4...20 mA		
	Resolution	9.76 mV or 0.019 mA (10 bit)		
	Maximum load	Voltage: ≥1kΩ Current: ≤500Ω		
<b>Environment</b>	Operation	To IEC 721-3-3 class 3K5		
	Climatic conditions	0...50 °C (32...122 °F)		
	Temperature	<85 % RH non-condensing		
	Humidity			
	Transport & storage	To IEC 721-3-2 and IEC 721-3-1 class 3K3 and class 1K3		
	Climatic conditions	0...50 °C (32...122 °F)		
Temperature	<95 % RH non-condensing			
Humidity	class 2M2			
Mechanical conditions				
<b>Standards</b>	Degree of protection	IP65 to EN 60 529		
	Pollution class	II (EN 60 730-1)		
	Safety class:	III (IEC 60536)		
	Overvoltage category	II (EN 60 730-1)		
<b>General</b>	Material	Flame retardant PC+ABS plastic (UL94 class V-0)		
	Dimensions (H x W x D)	47 x 98 x 90 mm (1.9 x 3.9 x 3.5 in)		
	Weight (including package)			
	with standard housing cover	192 g (6.8 oz)		
with OPC-S V2 operation terminal	239g (8.4 oz)			

## Dimensions, mm (inch)

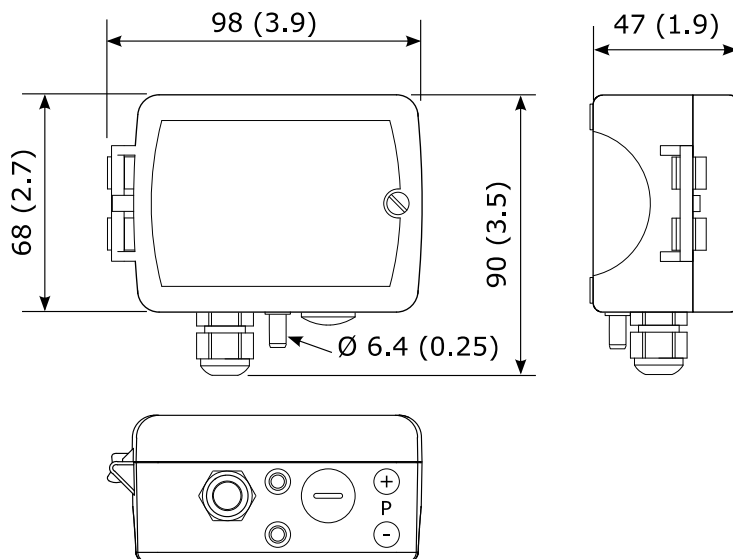

## Mounting and Installation

### Mounting instructions



For details see "SCC-P" install sheet, document no. 70-00-0999 on our webpage [www.vectorcontrols.com](http://www.vectorcontrols.com)

### Connection diagram

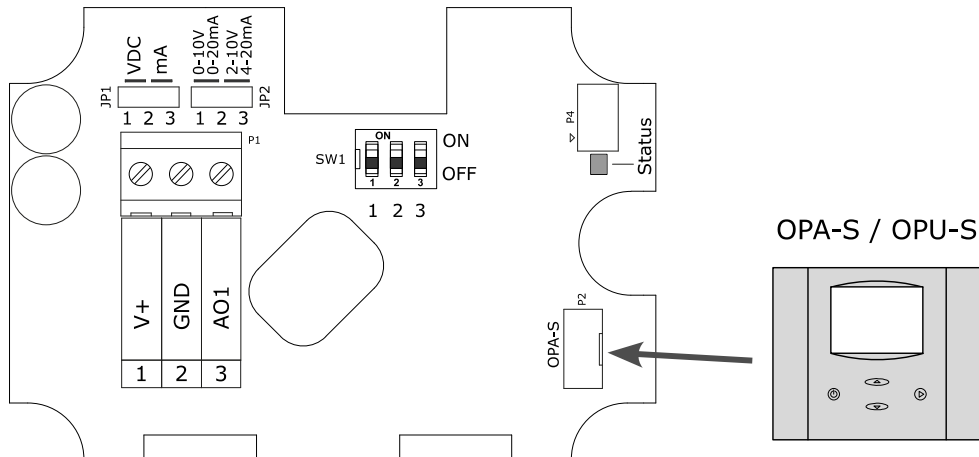

- 1 **+V** Power supply: 24 VAC 50-60 Hz, +24 VDC, ±10%
- 2 **GND** Power supply: 0 V, -24 VDC, internally connected to signal common
- 3 **AO1** Analog output: DC 0(2)...10 V  
DC 0(4)...20 mA

### Jumper settings

Analog output AO1

AO Mode	AO Range
<p>JP1</p> <p><input checked="" type="checkbox"/> VDC 1 2 3</p> <p><input type="checkbox"/> mA 1 2 3</p>	<p>JP2</p> <p><input checked="" type="checkbox"/> 0...10 V 1 2 3 <input type="checkbox"/> 0...20 mA</p> <p><input type="checkbox"/> 2...10 V 1 2 3 <input checked="" type="checkbox"/> 4...20 mA</p>

## Pressure range selection

The pressure range of the selected SCC-P type can be further adjusted according to the following table and by setting the DIP switches accordingly.



For other pressure ranges, set the DIP switch number to 0 and adjust the configuration parameter IP 03 and IP 04 accordingly.

For details see section "Configuration Parameters", page 7.

Number (DIP switch)	Pressure Range [Pa]	SCC-P Sensor Type		
		SCC-P2	SCC-P3	SCC-P4
0 <sup>1)</sup>	-100...100% <sup>2)</sup>	± 100 Pa	± 500 Pa	± 2500 Pa
1	0...100%	0...100 Pa	0...500 Pa	0...2500 Pa
2	0...40%	0...40 Pa	0...200 Pa	0...1000 Pa
3	-40...40%	± 40 Pa	± 200 Pa	± 1000 Pa
4	0...50%	0...50 Pa	0...250 Pa	0...1250 Pa
5	-50...50%	± 50 Pa	± 250 Pa	± 1250 Pa
6	0...60%	0...60 Pa	0...300 Pa	0...1500 Pa
7	-60...60%	± 60 Pa	± 300 Pa	± 1500 Pa

1) Standard position of DIP switch

2) Pressure range according to configuration parameter IP 03 and IP 04 (standard range -100%...100%)

## DIP switch positions

Number	Position DIP switch 1	Position DIP switch 2	Position DIP switch 3
0 <sup>1)</sup> =	OFF	OFF	OFF
1 =	ON	OFF	OFF
2 =	OFF	ON	OFF
3 =	ON	ON	OFF
4 =	OFF	OFF	ON
5 =	ON	OFF	ON
6 =	OFF	ON	ON
7 =	ON	ON	ON

1) Standard position

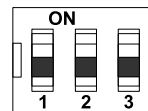

Figure 1: All DIP switches in position OFF

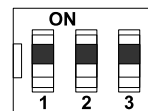

Figure 2: All DIP switches in position ON

## LED-indicator

A status LED is located inside of the transmitter housing.

During normal operation the LED blinks briefly once every 5 seconds.

If there is an alarm or fault condition it will light up steady.

During power up and if a setting is saved, it will light up for 3 seconds.



For details see OPA-S operation manual, document no. 70-00-0171 or OPU-S short instruction, document no. 70-00-0303.

## Configuration Parameters

The transmitter can be perfectly adapted to the application. Its parameters are set using the built-in operation terminal OPC-S V2 or the external operation terminals OPA-S / OPU-S. In order to use all the functions described below and to obtain a correct display, only OPA-S or OPU-S units with firmware version V1.5 or higher should be used.

### Pressure input configuration

Parameter	Description	Range	Standard
IP 00	Display of pressure signal: OFF = no unit, range is defined with IP06 and IP07, ON = range is fixed to -100 to 100%	ON/OFF	ON (%)
IP 01	Samples taken for averaging control signal. The SCC-P is a fast sensor. It measures every 0.1 seconds and applies a low pass filter that is controlled through this parameter. A setting of 20 equals an averaging time of about 3 seconds.	1...255	5
IP 02	Calibration	-10...10%	0
IP 03	Minimum pressure range: Pressure when output is at its minimum Note: This parameter is overwritten by the DIP-Switch. Customized settings must be done with DIP Switch position = 0	-100...100%	-100...100%
IP 04	Maximum pressure range: Pressure when output is at its maximum Note: This parameter is overwritten by the DIP-Switch. Customized settings must be done with DIP Switch position = 0	-100...100%	-100...100%
IP 05	Square root measurement functions OFF = linear measurement ON = the input signal is processed with a square root function	ON/OFF	OFF
IP 06*	Display value range. Converts the display range when IP00 is OFF. Value shown on the display unit when output is 100%. Can be used to visualize air pressure in Pa or inch H <sup>2</sup> O, air flow or air volume based on differential pressure.	0...255	100
IP 07*	Display value scale 0 = x 0.01 (only for OPU-S and OPC-S V2) 1 = x 0.1 (only for OPU-S and OPC-S V2) 2 = x 1 3 = x 10 4 = x 100	0...4	2
IP 08	Scaling factor. The measured value will be divided by this factor. Keep at 100% for standard applications.	0...100%	100%
IP 09	Auto zero interval: After each interval, the device will calibrate. Setting this value to 0, prevents automatic zero calibration.	0...255 h	24 h

See chapter "Display value as pressure (Pa, inches H<sup>2</sup>O) instead of percentage value (%)"

### Analog output configuration

Parameter	Description	Range	Standard
OP 00	Configuration output signal: 0 = Feedback pressure input 1 = Feedback pressure minimum value 2 = Feedback pressure maximum value	0...2	0
OP 01	Minimum limitation of output signal.	0...Max. %	0%
OP 02	Maximum limitation of output signal	Min....100%	100%

**Display value as pressure (Pa, inches H<sup>2</sup>O) instead of percentage value (%)**

When **IP 00 = OFF**, the following parameter combinations can be used to convert from percentage display to pressure display in Pa or inches H<sub>2</sub>O. These parameters do not affect the analog output value.

Parameter	SCC-P2		SCC-P3		SCC-P4	
	-100 ... 100 Pa	-0.40 ... 0.40 inch H <sup>2</sup> O	-500 ... 500 Pa	-2.00 ... 2.00 inch H <sup>2</sup> O	-2500 ... 2500 Pa	-10.0 ... 10.0 inch H <sup>2</sup> O
IP 00	OFF	OFF	OFF	OFF	OFF	OFF
IP 06	100	40	50	200	250	100
IP 07	2	0	3	0	3	1
Interpretation	100*1 = 100 Pa	40*0.01 = 0.4 inH <sup>2</sup> O	50*10 = 500 Pa	200*0.01 = 2 inH <sup>2</sup> O	250*10 = 2500 Pa	100*0.1 = 10 inH <sup>2</sup> O

Calculation of displayed pressure value:  $Value [\%] * IP06 * IP07$

Pa to inch H<sub>2</sub>O conversion:  $\frac{xxx Pa}{250} = xxx in H2O$

Empty page.

## Smart Sensors and Controls Made Easy!

### Quality - Innovation – Partnership

Vector Controls LLC  
USA

[infous@vectorcontrols.com](mailto:infous@vectorcontrols.com)  
[www.vectorcontrols.com](http://www.vectorcontrols.com)

