

## TCY-BH-U Humidistat

### Features

- Control for binary humidifiers and dehumidifiers with or without fan support
  - Low power energy consumption: < 1W per unit
  - Relays switching for outputs each up to 300W
  - Cost saving option with Economy functionality and setpoint limitations
  - External sensor input for setpoint setback based on outdoor temperature
  - Password protected programmable user and control parameters
    - Setpoint range limitation
    - Access control for setpoints and mode change
    - Access control for clock and time programs
    - Select your display contents
    - Selectable behavior after return from power failure
  - Temperature display of external input in Celsius or Fahrenheit
- Deluxe version:
- Clock and time schedule functions
  - Blue backlight for LCD

### Applications

- Humidifiers:
  - On / Off type humidifiers
  - On / Off type humidifiers with single speed fan support
- Dehumidifiers:
  - On / Off type dehumidifiers
  - On / Off type dehumidifiers with single speed fan support
- Combination humidifiers and dehumidifiers without fan support

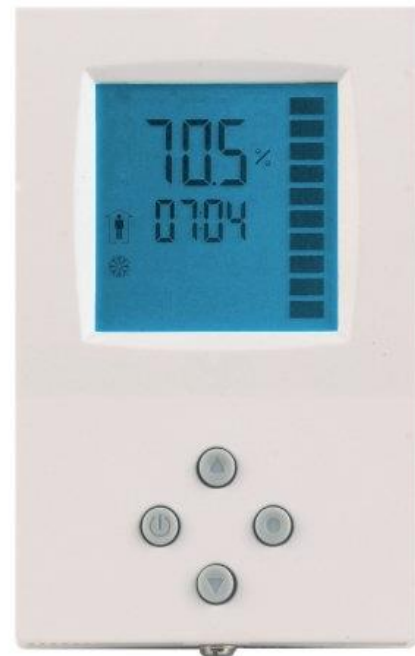

### General description

The TCY-BH-U is a stand-alone electronic binary humidity stat. The TCY-BH-U features one internal humidity sensor, one external NTC temperature sensor input and two binary outputs (Relays).

A detailed parameterization is possible with the use of a simple configuration routine. The TCY-BH-U can be configured using the standard operation terminal. No special tools or software is required.

### Ordering

Item name	Item code	Variant	Features
TCY-BH-U-W20	40-10 0055-20	standard humidifying de-humidifying	Binary controller with: 1 Internal humidity input 1 external temperature input (for setpoint shift) 1 DO (Relay) for humidifier or dehumidifier 1 DO (Relay) for fan (optional)
TCY-BH-U-W24	40-10 0055-24		
TCY-BH-U-W25	40-10 0055-25		
TCY-BH-U-D-W20	40-10 0056-20	Deluxe humidifying de-humidifying	-W20 = Humidify/dehumidify Deluxe = 7-day programmable
TCY-BH-U-D-W24	40-10 0056-24		
TCY-BH-U-D-W25	40-10 0056-25		

### Accessories

S-Tn10-2	40-20 0001		Flying lead sensor with 6 ft cable
SD-Tn10-12-2	40-20 0002		Flying lead duct sensor 4.7 inch immersion depth, 6 ft. cable
SD-Tn10-20-2	40-20 0003		Flying lead duct sensor 7.8 inch immersion depth, 6ft. cable
SDB-Tn10-12	40-20 0051		Duct sensor with housing, 4.7 inch immersion depth
SDB-Tn10-20	40-20 0004		Duct sensor with housing, 7.8 inch immersion depth
SOA-Tn10	40-20 0006		Outdoor sensor
AES3-HT-A5	40-50 0104		Replacement humidity sensor 5% accuracy

### Selection of devices and sensors

External temperature sensors: Use only our approved NTC sensors to achieve maximum accuracy. Recommended is SDB-Tn10-15 as duct sensor and SOA-Tn10 as outdoor sensor.

Binary auxiliary devices: E.g. humidifiers, de-humidifiers and fans. Do not directly connect devices that exceed 2(1.2)A. Observe startup current on inductive loads!

## Technical specification

### Safety advice

**Caution!** This device is intended to be used for comfort applications. Where a device failure endangers human life and/or property, it is the responsibility of the owner, designer and installer to add additional safety devices to prevent or detect a system failure caused by such a device failure. Vector Controls or its affiliates cannot be held liable for any damage caused by such a failure. Failure to follow specifications and local regulations may endanger life, cause equipment damage and void warranty.

<b>Power supply</b>	Operating voltage	24V AC/DC $\pm$ 10 %, 50...60 Hz, Class II, 48VA max
	Power consumption	Max. 1.5 VA
	Electrical connection	Terminal connectors, wire 0.34...2.5 mm <sup>2</sup> (AWG 24...12)
	Deluxe type only: Power backup for real time clock	Min 48h if charged for 24h
<b>Signal inputs</b>	Humidity input: Range Accuracy	Element: Polymer-Based Capacity Sensor 0...100 % r.H. 10%...90% r.H. $\pm$ 5.0 % 0...10% and 90...100% $\pm$ 7.0 %
	Hysteresis	$\pm$ 1% r.H.
	Temperature input Range Accuracy	External NTC (Sxx-Tn10 sensor): -40...70 °C (-40...158 °F) -40...0 °C (-40...32 °F): 0.5 K 0...50 °C (32...122 °F): 0.2 K 50...70 °C (122...158 °F): 0.5 K
	<b>Signal outputs</b>	Digital switching outputs Switching type AC Switching power
<b>Environment</b>	Operation Climatic conditions Temperature Humidity	To IEC 721-3-3 class 3 K5 0°C ...50°C (32°F...122°F) <95% R.H. non-condensing
	Transport & storage Climatic conditions Temperature Humidity Mechanical conditions	To IEC 721-3-2 and IEC 721-3-1 class 3 K3 and class 1 K3 -25°C...70°C (-13°F...158°F) <95% R.H. non-condensing class 2M2
<b>General</b>	Degree of protection	IP30 to EN 60 529
	Safety class	III (IEC 60536)
	Cover, back part Mounting plate	Fire proof ABS plastic (UL94 class V-0) Galvanized steel
	Dimensions (H x W x D) Front part: Power case:	112 x 73 x 15 mm (4.4" x 2.9" x 0.6") $\varnothing$ 58 x 32 mm ( $\varnothing$ 2.3" x 1.3")
	Weight (including package)	270g (9.5 oz)

### Dimensions mm (inch)

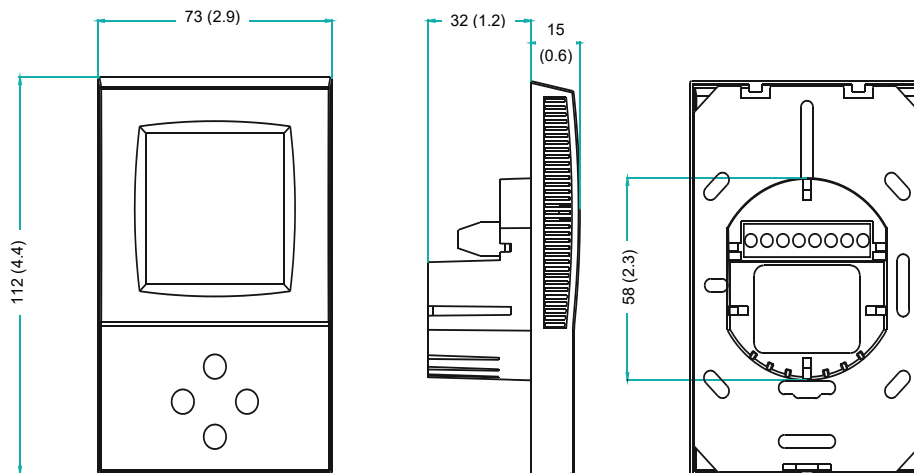

**Wiring diagram**

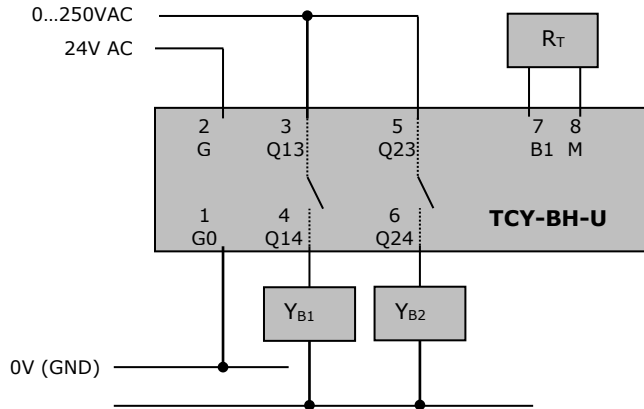

**Description:**

Connections depend on parameter CP10 and CP11! (See page 10)

CP10	YB1 DO1	YB2 DO2	RT
CP10 = 0	Humidify	Dehumidify	Temperature input for setback NTC 10kΩ @ 25°C (77°F)
CP10 = 1	Humidify	CP11 = ON: FAN	
CP10 = 2	If CP11 = ON: FAN	Dehumidify	

**Mechanical design and installation**

The unit consists of two parts: (a) The power case with attached mounting plate and (b) the front part.

**Mounting location**

- On an easy accessible interior wall, approx. 1.5 m (4.5') above the floor in an area of average temperature.
- Avoid exposure to direct sunlight or other heat sources, e.g. the area above radiators and heat emitting electrical equipment.
- Avoid locations behind doors, outside walls and below or above air discharge grills and diffusers.
- Location of mounting is less critical if external temperature sensors are used.

**Installation**

1. Connect the wires to be connected to the terminals of the power case according to wiring diagram
2. Install the mounting plate to the flush mounting box. Make sure that the nipple with the front retaining screw is at the bottom. Make sure the mounting screw heads do not stand out more than 5 mm (0.2") from the surface of the mounting plate.
3. Ensure that the jumpers are set correctly.
4. Slide the two latches located on the top of the front part into the hooks at the upper side of the mounting plate.
5. Carefully lower the front part until the interconnector reaches the mounting-plate. Continue pressing in a gentle way until the front part is fully connected. While inserting the connectors, a slight resistance can be felt. This is normal. Do not use excessive force!
6. With a Philips-type screw driver of size #2, carefully tighten the front holding screw to secure the front part to the mounting plate. This screw is located on the front lower side of the unit. There is no need to tighten the screw too much.

## Display and operation

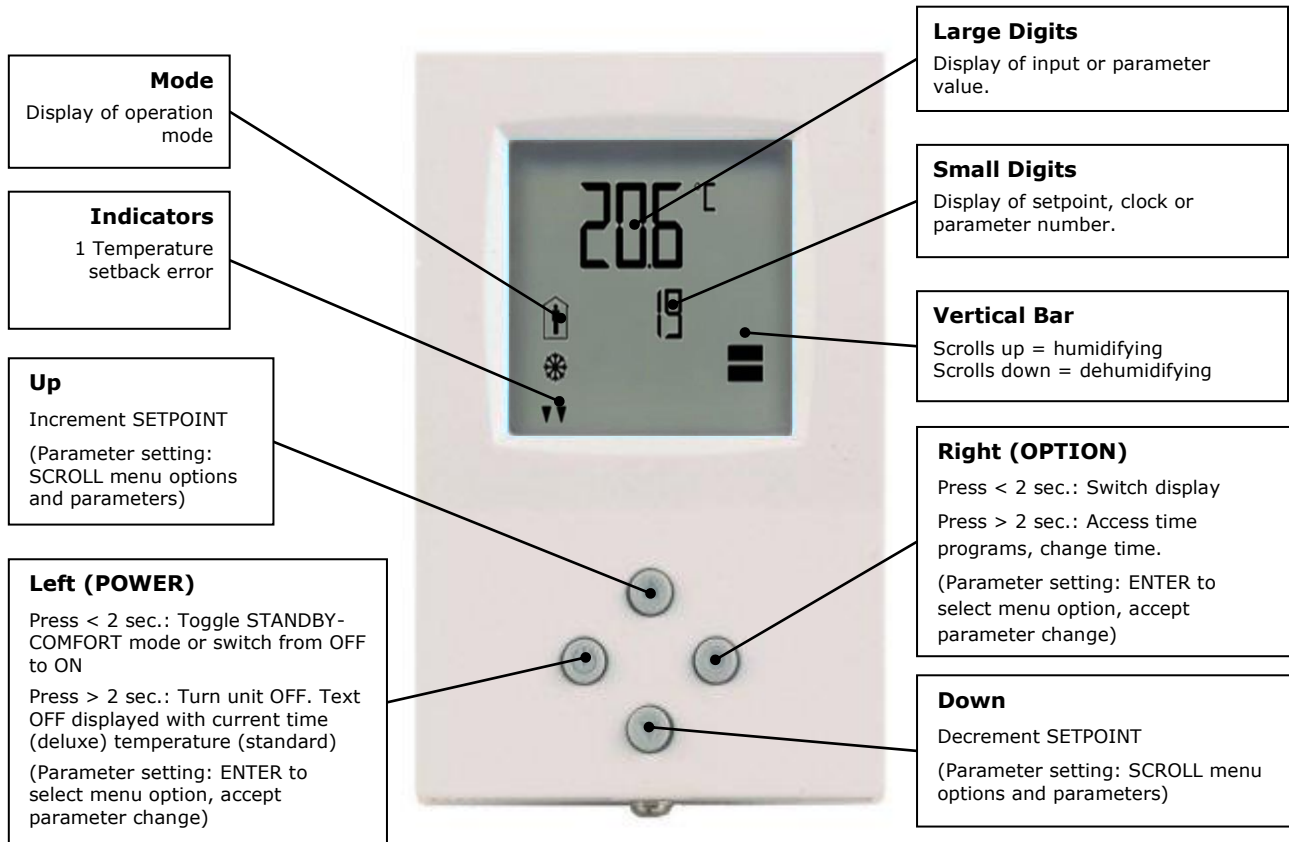

### Operation mode and state indication

	Comfort (occupied)	All control functions operating per setpoints.
	Economy (unoccupied):	Setpoints shifted according to <i>Parameters CP04</i> . Economy mode and setpoint shift may be disabled with UP04
<b>OFF</b>	Energy hold Off	Outputs are off, inputs monitored for alarm condition
	Fan active	Fan is running
	Temperature setback	Temperature setback is active and shifts setpoint

### Power failure

All the parameters and setpoints are memorized and don't need to be reentered. Depending on Parameter UP-03 the unit will remain switched off, switch on automatically or return to the operation mode it was in before the power failure. The deluxe version includes a real time clock with a 48h backup battery powered through a super capacitor. The time does not need to be re-entered after a power failure.

### Error messages

The TCY-BH-U may display the following error condition:

- Err1:** Humidity sensor faulty. The humidity sensor is damaged or removed. Verify if sensing element!
- Err2:** External input for temperature setback missing or damaged.

## Advanced user setup menu

To enter the advanced user setup menu, activate the controller by pressing the POWER button. Press the ENTER key for 3 sec until SEL is shown in the large digits. The menu can be left by pressing the POWER / ESC button or by not pressing a button for more than 5 minutes.

### Temperature Unit setup (°C/°F)

Start the advanced menu as described above. Select C-F with the UP/DOWN buttons.

Press the ENTER key to change the temperature unit (°C or °F).

Press the POWER button to exit the advanced user setup menu.

### Sensor calibration

Start the advanced menu as described above. Select CALH or CALt with the UP/DOWN buttons.

Small digits show CALH (internal humidity sensor calibration) and CALt (temperature setback sensor calibration). The current calibration value is displayed. Press ENTER and then change the value with the UP/DOWN buttons, and save it with the ENTER button.

### Clock setup (for deluxe versions only)

A blinking clock indicates that the time needs to be set. Time programs will not operate if the time is not defined.

- Start advanced menu as described above and select the clock display by pressing the UP or DOWN keys.
- The current time is now displayed in the small digits. Press the ENTER button to enter the clock setup. The minute digits start to blink and can be changed with the UP/DOWN buttons.
- Pressing ENTER saves minutes and steps to hours. The hour digits blink now and can be changed with the UP/DOWN buttons.
- Press ENTER again to step to the day setting. DAY1-7 is displayed. Day 1 stands for Monday, Day 2 for Tuesday and so forth. Select the day according to current weekday.
- Pressing ENTER again saves the settings and moves back to the SELECT menu. To leave the setup mode press the POWER button.

### Time schedules (for deluxe versions only)

Four individual time programs (Pro1, Pro2, Pro3, Pro4), each with four switching events, are available. A switching event changes the controller from one operation mode to another.

Time schedules and their switching events can be individually enabled. Make sure that undefined time schedules and switching events are disabled.

Enter the advanced menu as described above and select PRO by pressing UP or DOWN buttons. Press the ENTER key.

Pro1 is now shown in the large digits, while the number 1 is blinking. Select time schedule Pro1-Pro4 by using UP/DOWN keys and pressing the ENTER key.

- 1) Enable or disable the Pro1 time schedule. Choose ON or OFF with the UP/DOWN keys. The following steps will only be accessible if ON is selected. OFF disables this time schedule and its switching events.
- 2) Select day(s) with UP/DOWN. Day 1 stands for Monday, day 2 for Tuesday and so forth. Options are d1-7, d1-6, d1-5, d6-7, day1, day2, day3, day4, day5, day6, day7. This time schedule will be active during the selected day or days. Press ENTER to continue.

- 3) Select desired operation mode below with UP/DOWN, press ENTER to continue

Name on display	Function	Override reset
no	Switching event not used	
OFF	Operation mode changes to off mode	Reset is active
ECO	Operation mode changes to economy mode	Reset is active
ON	Operation mode changes to comfort mode	Reset is not active
UNI	Operation mode does not change	Reset is not active

- 4) Select switching time 00:00 to 23:45 in 15-minute steps with UP/DOWN.

- 5) Press ENTER to continue and repeat step 3 and 4 for each switching event.

UNI: University mode: This switching mode is used for rooms such as lecture rooms and auditoriums that might be occupied during a certain time. During this time the reset is not active. The unit will not start itself when UNI mode is active. It still needs to be manually activated. This is to avoid unnecessary heating or cooling of such rooms while they are not occupied.

Override reset function: The override reset applies when the unit is manually switched on, while in scheduled off or ECO mode. The unit will return to the scheduled mode when the reset time defined in UP08 expires.

Setting UP08 to 0 disables the override reset.

**Example**

From Monday to Friday the controller shall be in Comfort mode between 08:00 in the morning and 18:00 in the evening. Between 18:00 and 08:00 it shall be in OFF mode. One time schedule with two switching events is required to achieve this time schedule:

**Setting procedure:**

- Select the desired time schedule (Pro1) with UP/DOWN key,
- Press enter, select ON to activate Pro1 with UP/DOWN keys, Press enter,
- Select d1-5 (Monday – Friday) with UP/DOWN keys and confirm with ENTER key
- Select ON mode with UP / DOWN key and confirm with ENTER
- Select the time of the first desired switching event for Pro1 (ON mode) to 08:00 with the UP/DOWN keys;
- Press ENTER to conclude this switching event (first of 4 available).

## Configuration parameters

The TCY-BH-U is preset to work for most applications. For special requirements it can be fine-tuned to work ideally with a simple parameter setup routine. The parameters can be changed on the unit without the need of additional equipment.

### Identifying the firmware version

The parameters and functionality of controller depend on its firmware version and revision. It is therefore important to use a matching product version and parameter set. The Firmware version and revision version can be found when pressing simultaneously the ▲ and ▼ keys during several seconds. On the upper 7 segment display, the firmware version can be found, on the lower 7 segment display the current revision index (or "sub-version").

### Access to parameters

The TCY-BH-U is an *intelligent* controller and can be adapted to fit perfectly into your application. The control operation is defined by parameters. The parameters are set during operation by using the standard operation terminal.

The parameters are password protected. There are two levels of parameters: User operation parameters for access control settings and Expert parameters for control functions and unit setup. The passwords for user levels and expert levels are different. Only control experts should be given the control parameter password.

The parameters can be changed as follows:

1. Press UP and DOWN button simultaneously for three seconds. The display will indicate the firmware version in the upper large digits and the revision in the lower small digits. Pressing any key will show: CODE.
2. Select a password using UP or DOWN buttons. Select 009 in order to get access to the user parameters, 241 for controls parameters.  
Press OPTION after selecting the correct password.
3. Once logged in, the parameter is displayed immediately
4. Select the parameters with the UP/DOWN keys. Change a parameter by pressing the OPTION key. The MIN and MAX symbols show up and indicate that the parameter may be modified now. Use UP and DOWN key to adjust the value.
5. After you are done, press OPTION or POWER in order to return to the parameter selection level.
6. Press the POWER key again so as to leave the menu. The unit will return to normal operation if no key is pressed for more than 5 minutes.

## User parameters (code 009)

Parameter	Description	Setting Range	Factory Setting
UP 00	Enable change of operation modes	ON, OFF	ON (Enabled)
UP 01	Enable change of setpoints	ON, OFF	ON (Enabled)
UP 02	Enable access to Time programs	ON, OFF	ON (Enabled)
UP 03	State after power failure: 0 = Switched OFF, 1 = Switched ON, 2 = state before power failure	0, 1, 2	2
UP 04	Enable Economy functionality	ON, OFF	OFF (Disabled)
UP 05	Celsius or Fahrenheit, Select ON for Fahrenheit, OFF for Celsius	ON, OFF	-W20, 24, 25 ON (°F) -W00, 04, 05 OFF (°C)
UP 06	Select contents of small digits in standard mode: 00 = OFF 01 = Setpoint 02 = Humidity Sensor 03 = External Temperature Sensor 04 = Clock	0...5	04 Deluxe: show clock 01 Standard: show setpoint
UP 07	New: Resolution 0.5% or 1% RH OFF = Display resolution is 0.5% RH ON = Display resolution is 1% RH	ON, OFF	OFF (0.5% RH)
UP 08 Deluxe only	Clock display type: OFF = Show 24hour clock ON = Show 12hour clock (AM, PM)	ON, OFF	-W20, 24, 25 ON (12h) -W00, 04, 05 OFF (24h)
UP 09 Deluxe only	Reset timer for override mode: Only available for deluxe version 0 = Reset of override mode is not active. 1...255 = delay in minutes to return to scheduled operation if the device is activated while scheduled to be in OFF or ECO mode.	0...255	60 (Min)

## Control functions (code 241)

Warning! Only experts should change these settings! See user parameters for login procedure.

Parameter	Description	Range	Standard
CP 00	Minimum setpoint limit in humidification mode	0...100%	10%
CP 01	Maximum setpoint limit in humidification mode	0...100%	90%
CP 02	Minimum setpoint limit in de-humidification mode	0...100%	10%
CP 03	Maximum setpoint limit in de-humidification mode	0...100%	90%

### Controls configuration

CP 04	Economy humidity shift: The comfort (occupied) setpoint is shifted by the value set here. If humidifying is active the comfort setpoint will be decreased, if dehumidifying is active, the setpoint will be increased. (Enable with UP04.)	0...100%	10%
CP 05	This parameter is only used if CP10 = 0 <b>Dead zone span:</b> The Dead Zone Span defines the deviation setpoint to input value required for the controller to switch from humidifying to dehumidifying or vice versa. The output is off while the measured value is within the dead zone span. A negative dead zone is not possible.	0...100%	10%
CP 06	This parameter is only used if CP10 = 0 Delay on humidify – de-humidify change over	0...255 min	5 min
CP 07	Switching Hysteresis Defines the difference between switching on and switching off an output. A small hysteresis will increase the number of switching cycles and thus the wear on associated equipment.	0...100%	3%
CP 08	Delay OFF (Minimum running time) [MM:SS] Prevents a too short running cycle for the control output by setting a minimum running time	00:00 to 98:30	00:10s
CP 09	Delay ON (Minimum stopping time) [MM:SS] Prevents a too short running cycle for the control output by setting a minimum stopping time	00:00 to 98:30	00:10s
CP 10	Configuration of control mode 0 = W20 = Both Humidification and de-humidification 1 = W24 = Humidification only 2 = W25 = De-humidification only	0 - 2	TCY-BH-U-W20: 0 TCY-BH-U-W24: 1 TCY-BH-U-W25: 2

### Output configuration

CP 11	Enable fan (only if CP 10 ≠ 0)	ON, OFF	TCY-BH-U-W20: OFF TCY-BH-U-W24: ON TCY-BH-U-W25: ON
CP 12	Start delay for fan [MM:SS] (Time the fan runs before control output starts)	00:00 – 98:30	00:10
CP 13	Stop delay for fan [MM:SS] (Time the fan keeps running after control output stops)	00:00 – 98:30	01:30

### Control logic TCY-BH-U

System type	CP10	CP11	DO1	DO2
Humidify and de-humidify	0	OFF	Humidifying	Dehumidifying
Humidify only	1	OFF	Humidifying	OFF
Humidify with fan	1	ON	Humidifying	FAN
De-humidify only	2	OFF	OFF	Dehumidifying
De-humidify with fan	2	ON	FAN	Dehumidifying

### Fan delay

Once there is an output demand, the humidistat will first activate the fan, wait the required start delay time (CP12) and then activate the control output. This will ensure stable air for humidification or de-humidification.

The control output will be switched off when the setpoint is reached. The fan keeps running until stop delay (CP13) has expired. This will ensure that no left over humidity remains in the device or its ducts.

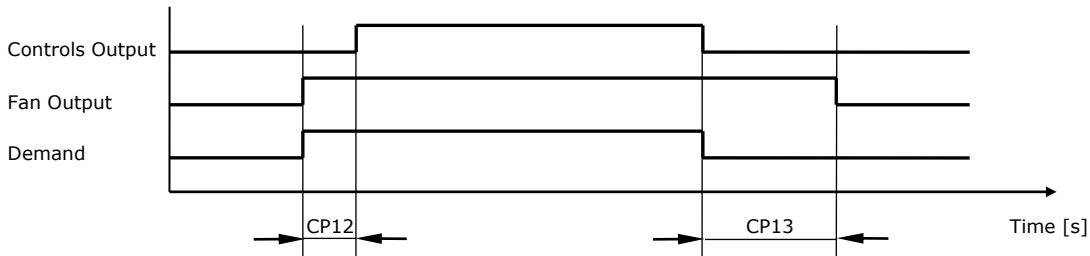

### Input configuration

CP 14	OFF = Temperature setback is disabled ON = Temperature setback is enabled	ON, OFF	OFF
CP 15	Setpoint limit at full setback	0...100%	20%
CP 16	Lower temperature limit: Outside temperature with maximum setback The setpoint will be equal to the minimum setpoint limit	-40...60°C -40...160°F	-30°C (-22°F)
CP 17	Upper temperature limit: Outside temperature at begin of setback.	-40...60°C 40...160°F	0°C (32°F)
CP 18	Number of seconds taken into account to calculate the averaging input signal. Low value = fast response High value = slow response	0...100	10

### Temperature setback (TSET)

Shift the humidity setpoint towards a defined TSET setpoint CP15 depending on the outdoor temperature.

Temperature setback becomes active when the outside temperature drops below the activation limit of temperature setback CP17. The full temperature setback is reached when the temperature reaches the full limit CP16. The actual setpoint will in this case be equal to the TSET setpoint.

Temperature setback may be enabled with CP14.

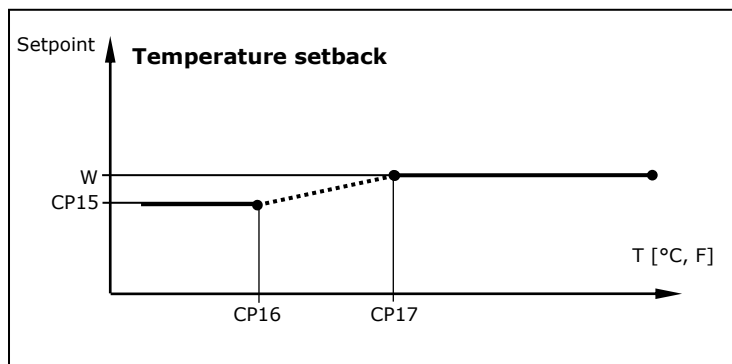

### Averaging function of input signal:

The averaging function is used to prevent unwanted fluctuation of sensor signals. The controller measures every second the signal inputs. The input signal is built over a number of measured values. Select how many values should be used to calculate the averaging signal. Control speed will slow down when a large number of samples are used for an averaging signal. This should be taken into account when defining the control parameters.

**Smart Sensors and Controls  
Made Easy!**

**Quality - Innovation – Partnership**

Vector Controls LLC  
USA

[infous@vectorcontrols.com](mailto:infous@vectorcontrols.com)  
[www.vectorcontrols.com/](http://www.vectorcontrols.com/)

