

## TLR-D5 with OPA-D5

### Intelligent Fan Coil controller: Cabinet mounted base, wall mounted operation terminal.

#### Features

- Temperature control for 2 and 4-pipe fan coil systems.
- Relays switching up to 10(6) A
- Automatic fan control for three stage fans.
- Control for heating, cooling and fan only operation
- Cost saving option with economy functionality and set point limitation
- For large rooms: Master - Slave option: One terminal may drive up to 8 base units in parallel.
- External sensor or potential-free contact for remote control, external heat/cool changeover, or automatic changeover based on supply or outdoor temperature with selectable activation limits. One terminal can control up to 8 base units in parallel.
- Password protected programmable user and control parameters
- Temperature display in Celsius or Fahrenheit



#### Deluxe Version:

- Clock and time schedule functions with special options for schools and universities
- Clock keeps running for 48h in case of power failure
- Display with blue backlight
- Infrared remote controller option:  
With special features for boost and delayed switching on or off

#### Applications

- Air Only Systems: Three stage fans for single duct systems.
- Air/Water Systems: Induction units, fan coil units for 2- and 4-pipe systems

### General Description

The TLR-D5 is a stand-alone electronic single loop controller with a fan control option and a binary sequence. The controller includes 1 NTC room temperature sensor and 3+2 relay outputs. A detailed adaptation to local conditions is possible with the use of a simple configuration routine. The TLR-D5 can be configured using the standard operation terminal. No special tools or software is required.

The TLR-D5 has been specifically developed to switch larger fans with switching power of up to 10(6) A.

#### Ordering

A working controller consists of one operation terminal and at least one base unit.

Item name	Item code	Function	Type	Key-data
TLR-D5-24	40-11 0017	24 VAC	Base unit	Fan coil controller with: 1 TI int or ext
TLR-D5-230	40-11 0018	230 VAC		
OPA-D5	40-10 0083	Standard	Operation Terminal (88x88mm)	3 DO (Relay) Fan control 2 DO (Relay) Binary control
OPA-D5-D	40-10 0084	Deluxe		

#### Parameter preset

-W01	40-10 00xx-01	Cooling only	Add -Wx at the end of the item name or -x at the end of item code to order pre-configured model
------	---------------	--------------	---

#### Accessories

OPR-1	40-50 0001	2xAAA batteries	Infrared remote controller
S-Tn10-2	40-20 0001	Flying lead sensor with 2 m cable	
SD-Tn10-12-2	40-20 0002	Flying lead duct sensor 12 cm immersion depth, 2 m cable	
SD-Tn10-20-2	40-20 0003	Flying lead duct sensor 20 cm immersion depth, 2 m cable	
SDB-Tn10-12	40-20 0051	Duct sensor with housing, 12 cm immersion depth	
SDB-Tn10-20	40-20 0004	Duct sensor with housing, 20 cm immersion depth	
SRA-Tn10	40-20 0005	Room sensor	
SOD-Tn10	40-20 0059	Outdoor sensor	

## Technical specifications

<b>Power Supply</b>	Operating voltage	TLR-D5-24	24 VAC ± 10 %, 50/60 Hz, SELV to HD 384, Class II transformer, 48 VA max	
		TLR-D5-230	230 VAC ± 10 %, 50/60 Hz	
	Power consumption	TLR-D5-24	Max. 3 VA	
		TLR-D5-230	Max. 5 VA	
	Electrical connection	Terminal Connectors	Wire 0.34...2.5 mm <sup>2</sup> (AWG 22...13)	
	Deluxe type only: Power backup for real time clock		Min 48 h if charged for 24 h	
<b>Signal inputs</b>	Temperature input	Range Accuracy	0...50 °C (32...122 °F) 0.5 °C, 1 °F	
<b>Signal outputs</b>	Digital switching outputs		DO1 to DO5	
	Switching type		Relays	
	AC switching power		0...240 VAC 10(6) A max. each output	
	Insulation strength			
	between relays contacts and system electronics:		3750V AC to EN 60730-1	
	between neighboring relays contacts		1250V AC to EN 60730-1 1<>2<>3, 4<>5	
	between relay groups:		3750V AC to EN 60730-1 1/2/3<>4/5	
<b>Communication base - terminal</b>	Communication type		Digital: peer to peer	
	Cable type:		Copper wire 0.8...2.5 mm <sup>2</sup> (AWG18...AWG13), shielded twisted pair	
<b>Environment</b>	Operation		To IEC 721-3-3	
	Climatic conditions		class 3 K5	
	Temperature		0...50 °C (32...122 °F)	
	Humidity		< 95 % RH, non-condensing	
	Transport & storage		To IEC 721-3-2 and IEC 721-3-1	
	Climatic conditions		class 3K3 and class 1K3	
	Temperature		-25...70 °C (-13...158 °F)	
	Humidity		< 95 % RH, non-condensing	
	Mechanical conditions		class 2M2	
<b>Standards</b>	CE conformity EMC Directive Low voltage directive		2004/108/EC	
			2006/95/EC	
	Product standards			
	Automatic electrical controls for household and similar use			EN 60730-1
	Special requirement on temperature dependent controls			EN 60730- 2- 9
Electromagnetic compatibility for domestic sector			Emissions: EN 60730-1 Immunity: EN 60730-1	
<b>General Terminal</b>	Safety class		III (IEC 60536)	
	Degree of protection		IP30 to EN 60529	
	Material	Cover, back part	ABS plastic (UL94 class V-0)	
		Mounting plate	Galvanized steel	
	Color		White RAL 9003	
	Dimensions (H x W x D)		88 x 88 x 24 mm (3.5 x 3.5 x 0.9 in)	
	weight including package	OPA-D5	180 g (6.3 oz)	
	OPA-D5-D	190 g (6.7 oz)		
<b>General Base</b>	Safety class		II (IEC 60536)	
	Degree of protection		IP20 to EN 60 529	
	Housing material		PC+ABS plastic (UL94 class V-0)	
	Color		Gray (RAL 7001 / 7035)	
	Dimensions (H x W x D)		57 x 147 x 115 mm (2.25 x 5.8 x 4.5 in)	
	Weight including package	TLR-D5-24	345 g (12.2 oz)	
		TLR-D5-230	445 g (15.7 oz)	

## Dimensions, [mm] (inch)

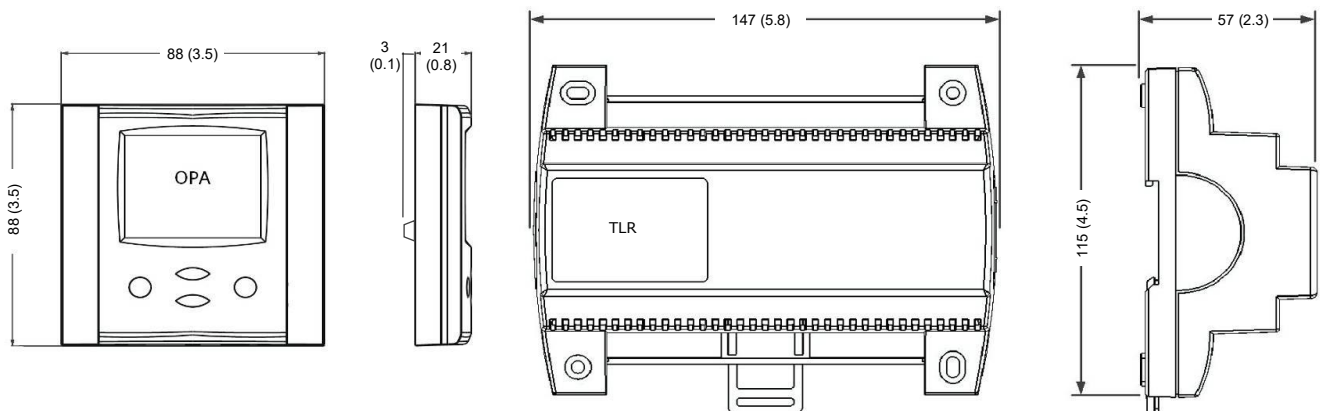

## Selection of actuators and sensors

Temperature sensors: Use only approved NTC sensors to achieve maximum accuracy. See ordering for details.

Binary auxiliary devices: E.g. fans and on/off valves. Do not directly connect devices that exceed maximum switching currents as detailed under technical specifications. Observe startup current of fans.

## Wiring diagram

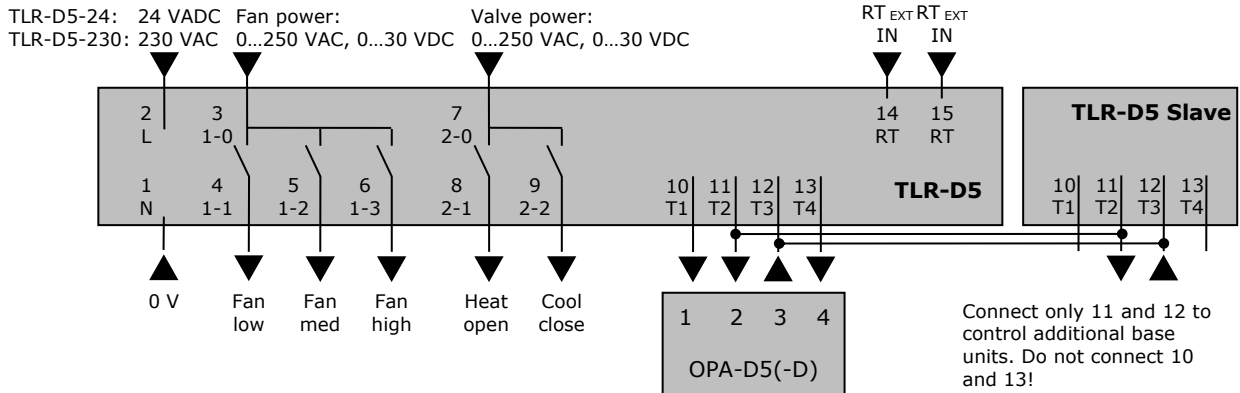

### Description:

<b>1</b>	<b>N</b>	Power supply:	TLR-D5-24: 0 VAC, 24 VDC TLR-D5-230: 230 VAC
<b>2</b>	<b>L</b>	Power supply:	TLR-D5-24: 24 VAC, 24 VDC TLR-D5-230: 230 VAC
<b>3</b>	<b>1-0</b>	Switched common for fan:	0...250 VAC, 0...30 VDC
<b>4</b>	<b>1-1</b>	Binary output:	Fan speed low
<b>5</b>	<b>1-2</b>	Binary output:	Fan speed medium
<b>6</b>	<b>1-3</b>	Binary output:	Fan speed high
<b>7</b>	<b>2-0</b>	Switched common for valve:	0...250 VAC, 0...30 VDC
<b>8</b>	<b>2-1</b>	Binary output:	Valve (heating in 4-pipe mode, open for three state outputs)
<b>9</b>	<b>2-2</b>	Binary output:	Valve (cooling in 4-pipe mode, close for three state outputs)
<b>10</b>	<b>Term1</b>	Terminal connection 1	Connect to operation terminal
<b>11</b>	<b>Term2</b>	Terminal connection 2	Connect to operation terminal
<b>12</b>	<b>Term3</b>	Terminal connection 3	Connect to operation terminal
<b>13</b>	<b>Term4</b>	Terminal connection 4	Connect to operation terminal
<b>14</b>	<b>RT</b>	External temperature input:	Sxx-Tn10 or open contact
<b>15</b>	<b>RT</b>	External temperature input:	Sxx-Tn10 or open contact

### Installation Base

The housing of the TLR base unit is a robust plastic enclosure. The controller may be mounted in any orientation by surface mounting on a wall or in a cabinet. 4 mounting-holes for screws up to 4 mm diameter are provided. Mounting onto a standard 35 mm DIN rail is also possible.

When mounting note the following:

- The controller should not be freely accessible after mounting. A protective housing should be used, if mounted outside an electrical cabinet.
- Ensure adequate air circulation to dissipate heat generated during operation.**
- Local installation regulations must be observed.

### Installation Terminal

- Install the mounting plate to the electrical connection box. Make sure that the nipple with the front holding screw is facing down. Make sure the screw heads do not stand out more than 5 mm of the surface of the mounting plate.
- Connect the wires of the terminals to the communication wires according wiring diagram
- Slide the two latches located on the top of the front part into the hooks of the mounting plate.
- Lower the front part until located flat on the wall and the mounting plate is not visible anymore. Make sure the connection cable does not get in the way.
- Tighten the front holding screw to secure the front part to the mounting plate.

### Connection base to terminal

- Max. distance: 200 m (565 ft.)
- Twisted-pair copper wires may be used for wiring in an EMC-safe environment. In an impaired EMC environment use only shielded cables. The operating voltage must comply with the requirements for safety extra-low voltage (SELV) as per EN 60730.
- 1 terminal may drive up to 8 base units. See wiring for parallel connections. Total wire distance should not exceed 200 m.
- Conductor resistance will influence external temperature reading. 450 Ω will result in an increase of 1 °C (2 °F). Compensate using UP-08 if external temperature is used to control unit.

## Display and Operation

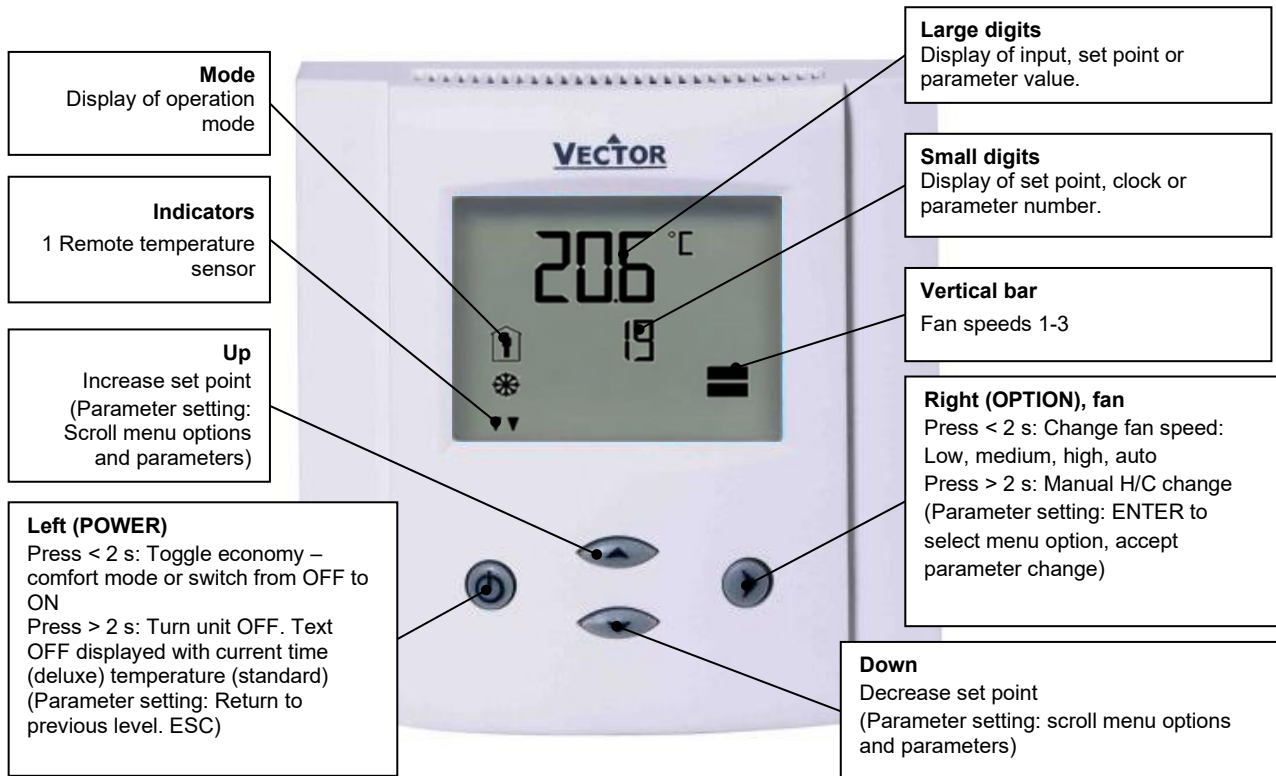

## Operation modes and symbols

	Comfort (occupied)	All control functions operating per set points.
	Economy (unoccupied):	Set points shifted according to <i>Parameters FC04</i> . Economy mode and set point shift may be disabled with UP06
<b>OFF</b>	Energy hold off	Outputs are off, inputs monitored for alarm condition
	Heating	Output activates if temperature lower than set point
	Cooling	Output activates if temperature higher than set point
	Fan	Fan is running, the vertical bars show active speed 1-3
	Manual	Manual override of fan speed, fan only mode or override of time schedule
	Time schedule	A time schedule is active

## Display of set point instead of current temperature

As standard the current temperature is shown in the large digits. Should only the set point be shown, select UP10 = 1. The current temperature will then not be visible anymore.

## Power failure

All the parameters and set points are memorized and do not need to be reentered. Depending on **UP05** the unit will remain switched off, switch on automatically or return to the operation mode it was in before the power failure.  
*Deluxe version only:* Timer operation and daytime setting will be retained for 24 h. The controller has to be connected to a power supply for at least 10 hours for the backup function to operate accordingly.

## Frost protection

The controller will enter frost protection mode if the room temperature drops below 5 °C (41 °F). All heating outputs will be fully opened. Frost protection mode will be left once the temperature reaches 10 °C (50 °F). Frost protection display will remain until a button is pressed. Frost protection can be enabled/disabled using user parameter UP-09.

## Error messages

- Err1:** Temperature sensor faulty. The temperature sensor is damaged.  
**Err2:** External input for heat / cool auto change over missing or damaged.  
**FP:** Steady: Frost protection is active.  
 Blinking: Frost protection activated in the past and is now inactive. Confirm with OPTION key.

## Status LED

The status LED is located on the TLR-D5 base unit between the two low power terminal connector groups. The status LED may display the following feedback:

- No light: No power or unit is damaged  
 Blink every 1s: Error, terminal - base unit do not match or signal is not clear  
 Blink every 2s: Normal communication, base unit detected  
 Blink every 5s: Base unit operates normal, no terminal detected

## Manual heat – cool – fan only change

To manually change heating / cooling / fan only mode press the OPTION key for more than 2 seconds. Access to manual heat – cool and/or fan only mode may be disabled by parameter UP03.

<p>For standard models: Press OPTION &gt; 2 s SEL and H-C is displayed.          For deluxe models: Press OPTION &gt; 2 s SEL and current time is displayed.          Press UP key twice. SEL and H-C is displayed.          Press OPTION again to toggle heating, cooling and fan only modes.</p>	<p>SEL H-C</p>
--	--------------------

## Clock operation

The deluxe model contains a quartz clock with battery back-up. Up to 4 time schedules with each 4 mode changes based on time and day of the week may be programmed. A blinking clock indicates that the time has not been set or if the unit was without power for longer than 48 hours. The time needs to be set to allow time schedules to operate.

### Clock setup

<p>Press OPTION &gt; 2 s SEL and current time displayed          Press OPTION &lt; 2 s to change time,          Minutes blink: UP/DOWN to changes, OPTION to save,          Hours blink: UP/DOWN to changes, OPTION to save,          Press OPTION to save time,          DAY1 blinks: UP/DOWN to change, OPTION to save</p>	<p>SEL 00:00 DAY1 (Mon)</p>
--	-------------------------------------

## Creating time schedules

### Step 1: Selection and enabling of time schedules

<p>Press OPTION &gt; 2 s SEL and current time displayed          Press UP:          SEL and PRO displayed, clock symbol blinks          Press OPTION:          PRO1 shows with 1 blinking. UP/DOWN select time schedule group          Press OPTION          OFF/ ON blinks, UP/DOWN to change, OPTION to save</p>	<p>SEL PRO</p>	<p>Pro1-Pro4 OFF/ON</p>
--	--------------------	-----------------------------

### Step 2: Select weekdays

<p>This time schedule will be active during the selected weekdays          Press UP/DOWN to step through available options:          d1-7, d1-6, d1-5, d6-7, day1, day2, day3, day4, day5, day6, day7          Day 1 stands for Monday, day 2 for Tuesday and so forth          Press OPTION to save day selection</p>	<p>Pro1 d1-7</p>
--	----------------------

### Step 3: Selected action of first switching event

<p>One bar on the right side indicates the first switching event          Press UP/DOWN to select action for first switching event:          No = switching event not active          OFF = switches unit off, Reset (UP17) active if switched to ON manually.          Eco = sets operation mode to on and economy (not occupied),          reset (UP17) active if set to comfort manually          On = sets operation mode to On and Comfort (occupied)          Uni = University mode, Reset (UP17) not active if manually activated          Press OPTION to select switching time of first event</p>	<p>Pr01 no</p>
--	--------------------

### Step 4: Selected time of first switching event

<p>Press UP/DOWN to select switching time:          Select switching time 00:00 to 23:45 in 15-minute steps          Press OPTION to complete and select action of second switching event</p>	<p>Pr01 08:00</p>
---	-----------------------

### Step 5: Select actions and time of switching event 2 - 4

<p>Repeat Step 3 and Step 4 for the remaining switching events.          If a switching event is not needed, set it to "no"          The bars on the right side indicate number of switching event          After completing the 4<sup>th</sup> switching event, the process returns to the selection of the time schedule on step 1.</p>	<p>Pr01 08:00</p>
---	-----------------------

- UNI: University mode: This switching mode is used for rooms such as lecture rooms and auditoriums that might be occupied during a certain time. During this time the reset is not active. The unit will not start itself when UNI mode is active. It still needs to be manually activated. This is to avoid unnecessary heating or cooling of such rooms while they are not occupied.
- A blinking clock indicates that the time needs to be set. Time programs will not operate if the time is not defined. See chapter operation, advanced settings for instructions on how to set the time.
- Access to time schedules may be disabled with UP-04

## Operation with OPR-1

The deluxe version may be alternatively operated with an infrared remote controller.

1. Mode indication, Auto, Dry, Cool, Fan, Heat
2. 2-digit display of set point
3. Fan indication
4. 4-digit display of current time or delayed switching time
5. Economy button: Toggles between economy and comfort mode
6. Mode button, changes operation modes
7. UP/DOWN Button: Set point adjustment buttons
8. FAN Button: Changes fan speed, low – medium – high or auto
9. Boost button, activates full output for 5 Minutes
10. Time related buttons: Timer, Hour, Minute
11. POWER Button: Operation mode ON – OFF

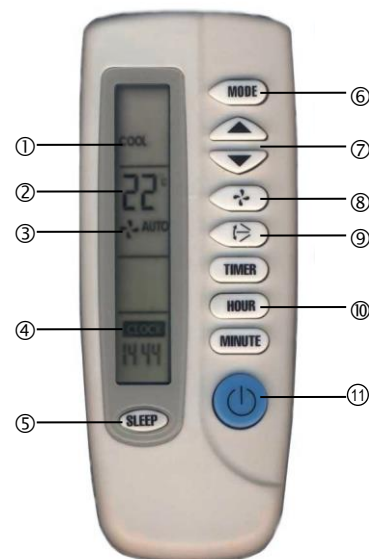

### Switching ON

The unit is switched on by pressing the POWER button. It will start up in comfort mode.

### Changing between COMFORT and ECONOMY

Pressing the SLEEP button toggles between ECONOMY and COMFORT modes.

### Switching OFF

Pressing the POWER while the unit is on, will switch the unit off. The current time will be displayed in the LCD of OPR-1.

### Changing of set points

Only the set points for the temperature loop may be changed. Set point range is 15 to 30 °C.

### Changing of fan speeds

Repeatedly pressing the fan speed button steps through low, medium, high and automatic fan speeds. Automatic fan speed will not be activated in FAN ONLY mode.

### Boost

Pressing the boost button activates a 5 minute boost. The output will be fully opened for the period of 5 minutes independent of demand. This may be used to change stale air during a meeting break or when entering the room.

### Clock settings

The remote controller contains a daytime clock. In order to set the clock, press HOUR and MINUTE button together until the clock starts blinking. Then set the correct time with the HOUR and MINUTE buttons. Confirm by pressing the TIMER button. The clock of the OPR will set the clock of the controller.

### Delayed switching

The unit may be delayed switched on or off using the timer button. Pressing the timer button once will display Timer ON if currently in OFF mode or TIMER OFF if currently in ON mode. Set the time when the unit is supposed to switch on or off using the HOUR and MINUTE buttons.

### Mode changes

Repeatedly pressing the mode button may activate the following operation modes: HEAT, COOL and FAN ONLY. The mode change may be disabled using the UP parameters.

Note:

The remote controller is currently only available in °C mode.

## Setting of user parameters

The TLR-D5 is an *intelligent* controller and can be adapted to fit perfectly into your fan coil application. The control operation is defined by parameters. The parameters are set during operation by using the standard operation terminal. The parameters are password protected. There are two levels of parameters: User operation parameters for access control settings and Expert parameters for control functions and unit setup. The passwords for user levels and expert levels are different. Only control experts should be given the control parameter password.

The parameters can be changed as follows:

1. Press UP and DOWN button simultaneously for three seconds. The display will indicate the firmware version in the upper large digits and the revision in the lower small digits. Pressing any key will show: CODE.
2. Select a password using UP or DOWN buttons. Select 009 in order to get access to the user parameters, 241 for controls parameters. Press OPTION after selecting the correct password.
3. Once logged in, the parameter is displayed immediately
4. Select the parameters with the UP/DOWN keys. Change a parameter by pressing the OPTION key. The MIN and MAX symbols show up and indicate that the parameter may be modified now. Use UP and DOWN key to adjust the value.
5. After you are done, press OPTION or POWER in order to return to the parameter selection level.
6. Press the POWER key again so as to leave the menu. The unit will return to normal operation if no key is pressed for more than 5 minutes.

### User parameters (access code: 009)

Parameter	Description	Range	Factory setting
UP 00	Enable change of operation modes	ON, OFF	ON (enabled)
UP 01	Enable change of set points	ON, OFF	ON (enabled)
UP 02	Enable manual control of fan speeds	ON, OFF	ON (enabled)
UP 03	Enable manual change of heating/cooling/fan only mode 0 = manual mode change disabled 1 = fan only enabled 2 = manual heat/cool mode change enabled 3 = manual heat/cool/fan only mode enabled	0, 1, 2, 3	W00: 3 (heat/cool/fan only) W01: 1 (fan only)
UP 04	Enable access to time programs	ON, OFF	ON (enabled)
UP 05	State after power failure: 0 = Switched OFF, 1 = Switched ON, 2 = state before power failure	0, 1, 2	2
UP 06	Enable economy (unoccupied) mode. Shift the set point to a lower temperature in winter or higher temperature in summer in order to save energy. Economy mode may be activated through the POWER button, or with the external input (typically for key card switches in hotel rooms or motion detectors for meeting rooms.)	ON, OFF	ON (economy )
UP 07	Celsius or Fahrenheit, Select ON for Fahrenheit, OFF for Celsius	ON, OFF	OFF (Celsius)
UP 08	Calibration value of temperature sensor. This value is calibrated at manufacturing of the thermostat. If required it is possible to shift the temperature $-10^{\circ}$ to $+10^{\circ}$ in $0.1^{\circ}$ K steps.	-10...10	0
UP 09	Enable frost protection. Activates the output independent of operation mode when the control temperature drops below $5^{\circ}\text{C}$ or $41^{\circ}\text{F}$ . The controller returns to normal operation when the temperature increases above $10^{\circ}\text{C}$ or $50^{\circ}\text{F}$ .	ON, OFF	W00 = ON (Frost protection) W01 = OFF (No frost protection)
UP 10	Select contents of large LCD digits in standard mode: 00 = OFF 01 = Set point 02 = Temperature sensor 03 = Output fan speed 04 = Clock 05 = Alternative sensor	0...5	02 Temperature
	*1) Note: if UP10 = 1, the set point will be shown instead of the measured temperature also in controls display.		
UP 11	Select contents of small LCD digits in standard mode: 00 = OFF 01 = Set point 02 = Temperature sensor 03 = Output fan speed 04 = Clock 05 = Alternative sensor	0...5	04 Deluxe: show clock 01 Standard: show set point
UP 12 Deluxe only	Clock display type: OFF = Show 24 hour clock ON = Show 12 hour clock (AM, PM)	ON, OFF	OFF (24h)
UP 13 Deluxe only	Reset: applies when the unit is manually switched on, while in scheduled off mode. The unit will switch automatically back to the scheduled mode when the reset time expires. 0 = Reset of override mode is not active. 1...255 = delay in minutes to switch off device	0...255	60 (min)

## Control configuration

### Identifying the firmware version

The parameters and functionality of controller depend on its firmware revision. It is therefore important to use a matching product version and parameter set. The firmware version is shown on the large LCD digits when pressing UP and DOWN buttons for more than 3 seconds simultaneously.

### Control parameters (access code: 241)

Warning! Only experts should change these settings! See user parameters for login procedure.

Parameter	Description	Range	Standard
FC 00	Minimum set point limit in heating mode	-40...60 °C (160 °F)	16 °C (61°F)
FC 01	Maximum set point limit in heating mode	-40...60 °C (160 °F)	24 °C (75°F)
FC 02	Minimum set point limit in cooling mode	-40...60 °C (160 °F)	18 °C (64 °F)
FC 03	Maximum set point limit in cooling mode	-40...60 °C (160 °F)	30 °C (86 °F)

### Controls configuration

FC 04	Economy (unoccupied) Mode temperature shift: The comfort (occupied) set point is shifted by the value set with parameter. If heating is active the comfort set point will be decreased, if cooling is active, the set point will be increased. (Enable with UP06.)	0...10.0 °C (20.0 °F)	5.0 °C (10 °F)
FC 05	Switching span heating, if set to 0, only 1 fan speed will be used	0...10.0 °C (20.0 °F)	0.9 °C (1.8 °F)
FC 06	Switching span cooling if set to 0, only 1 fan speed will be used	0...10.0 °C (20.0 °F)	0.7 °C (1.4 °F)
FC 07	Switching hysteresis is the difference between switching on and switching off. A small hysteresis will increase the number of switching cycles and thus the wear on fan and relays contacts.	0...10.0 °C (20.0 °F)	0.5 °C (1 °F)
FC 08	Mold protection: In mold protection, the fan keeps running independent of temperature as long as the unit is switched on.	ON, OFF	OFF
FC 09	Switching delay min running time of fan speed	0...255 s	10 s
FC 10	Switching delay min stopping time of fan speed	0...255 s	10 s
FC 11	Control option: 0 = Cooling only 1 = Heating only 2 = 2-pipe system 3 = 4-pipe system 4 = cooling with fan support, heating without fan support	0...4	-W00 = 2 -W01 = 0
FC 12	Dead zone span: The dead zone span lies between the heating and the cooling set point. The output is off while the temperature is within the dead zone span. A negative dead zone is not possible.	0-100 °C (200 °F)	1.0 °C (2 °F)
FC 13	Heat/cool changeover delay (if set to FC11 = 3): A demand to switch between heating and cooling must persist for the length of time set with this parameter before the controller switches. Prevents activation of a sequence during a short-term change in temperature in order to protect equipment (with control overshoot for example)	0...255 min	5 min

### Output Parameters

FC 14	Output setting, binary or 3-point: OFF = Binary (DO4 Heating, DO5 Cooling) ON = 3-point output (DO4 OPEN, DO5 CLOSE)	ON, OFF	OFF
FC 15	Reversing valve in binary mode 0 = no reversing valve (DO4 Heating, DO5 Cooling) 1 = reversing valve while heating (DO4 R. Valve, DO5 comp.) 2 = reversing valve while cooling (DO4 Comp, DO5 R. valve)	0...2	0
FC 16	Running Time in 3-point mode	0...255 s	90 s

#### → 3-point floating:

For floating point outputs the running time of the actuator used needs to be specified with FC16. Running time is defined as the time required for the actuator to run from fully open to fully closed and vice versa. Actuators with a fixed running time are recommended. Once fully open or fully closed the running time for the actuator is extended for a full run-time cycle. This will allow the actuator position to be synchronized in case it has been moved during off time or an actuator with variable running time was used.

## Input configuration

Parameter	Description	Range	Standard
FC 17	External input: 0 = No external input 1 = External temperature sensor 2 = Occupation sensor – comfort / economy 3 = Occupation sensor – comfort / off 4 = Heat / cool change by open contact. Contact open = heat 5 = Heat / cool change by open contact. Contact open = cool 6 = Auto-changeover based on supply temperature 7 = Auto-changeover based on outside temperature 8 = Key card with alternative set point 9 = Key card with full reset after inserting card	0..9	0
FC 18	Activation delay (minutes) = the time the binary input needs to be open before economy/off mode is activated.	0...255 min	5
FC 19	Auto-changeover limit cooling for supply temperature FC17 = 6 Auto-changeover limit heating for outside temperature FC17 = 7 or economy set point in heating mode if FC17 = 8	-40...60 °C (160 °F)	16 °C (61 °F)
FC 20	Auto-changeover limit heating for supply temperature FC17 = 6 Auto-changeover limit cooling for outside temperature FC17 = 7 or economy set point in cooling mode if FC17 = 8	-40...60 °C (160 °F)	28 °C (82 °F)
FC 21	Comfort set point in heating mode if FC17 = 9	-40...60 °C (160 °F)	21 °C (70 °F)
FC 22	Comfort set point in cooling mode if FC17 = 9	-40...60 °C (160 °F)	24 °C (75 °F)

## Configuring the external input

FC17 = 0	Input not used	
FC17 = 1	External control input	The external sensor is the control input.
FC17 = 2	Switching economy and comfort modes	Economy (unoccupied) and comfort (occupied) modes are controlled through an external contact by connecting the input through a dry contact to signal common. This function may be used together with key card switches for hotels or motion detectors for offices.
FC17 = 3	Switching energy hold OFF and comfort modes	Opening the input will force the unit into the OFF operation mode. The operation mode cannot be overridden by using the terminal. Connecting the input to signal common returns control of the operation mode to the terminal. This function may be used as window contact to prevent loss of energy.
FC17 = 4	Heat - cool changeover by contact	Switch by open contact: Contact open = heating is active, contact closed = cooling is active.
FC17 = 5	Heat - cool changeover by contact	Switch by open contact: Contact open = cooling is active, contact closed = heating is active.
FC17 = 6	Auto heat cool change-over by supply temperature	Connect a supply media sensor to the input. Cooling will be activated if a temperature below FC19 is measured. Heating is activated if a value above FC20 is measured
FC17 = 7	Auto heat cool change-over by outdoor temperature	Connect an outdoor temperature sensor to the input. Cooling will be activated if a temperature above FC20 is measured. Heating is activated if a value below FC19 is measured
FC17 = 8	Key card with alternative set point	As with FC17 = 2, the key card function switches economy (unoccupied) and comfort (occupied) modes. Instead of using the set point shift, the set points in unoccupied mode are defined by parameter FC19 in heating mode and FC20 in cooling mode. Fan speed in unoccupied mode is limited to low speed.
FC17 = 9	Key card with full reset	Similar as FC17 = 8 with the difference that set points, fan speed and operation made are reset each time the key card is inserted. This is helpful for business hotels.

**Smart Sensors and Controls  
Made Easy!**

**Quality - Innovation – Partnership**

Vector Controls GmbH  
Switzerland

info@vectorcontrols.com  
www.vectorcontrols.com

