

**SRD2**

**SRD2-TOPIR**

**SRD2-OPIR**



---

## Programmable Differential Pressure Controller and Transmitter SRD2-THP

---

The SRD2 is a wall-mounted programmable differential pressure controller and transmitter with communication capabilities. Each control loop may use 2 PI sequences and multiple binary stages. The SRD2 comes with a built-in isolated RS485 communication interface that allows peer-to-peer communication with an operation terminal such as OPT1-(2TH)-VC. An optional built-in 3.5 in touch screen or a color display with touch buttons provide a perfect and flexible way to interact with the user.

Complete parameter sets may be copied by use of an accessory called AEC-PM2 or exchanged with a PC and the EasySet program using an RS485-USB converter or via Wi-Fi. The SRD2 uses the Vector Controls universal and flexible X2 operating system and is preconfigured according to this documentation.

### Functions

- Four universally configurable control loops:
  - Functions for dehumidifying, set point shift and cascade control
  - Multiple auxiliary functions: heat-cool auto changeover, automatic enable, set point compensation
  - Free heating and cooling with economizer function based on enthalpy or temperature
  - Differential, averaging, min and max functions, enthalpy and dew point calculations
  - Transmitter function for sensors and set points
- Measures:
  - Differential Pressure with static or dynamic pressure sensors
  - Temperature
  - Humidity
- A passive infrared sensor (-IR type) which can be used for motion detection (occupied / unoccupied)
- 1.44 in Color display with backlight and touch button operation (-OP type)
- 3.5 in Capacitive touch color display (-TOP-type)
- Built-in humidity and temperature sensor (-TH type), CO2 sensor (-C type), VOC sensor (-Q type), dust particle sensor (-D type)
- 3 analogue voltage outputs (VDC) and one relay with a normally open and a normally closed contact (SPDT)
- 8 freely assigned alarm conditions, selectable state of outputs on alarm condition and alarm sound
- Serial Modbus RTU/ASCII or BACnet MS/TP via isolated RS485
- Modbus TCP or BACnet/IP via Wi-Fi
- Webserver for SRD2 operation from computer / mobile device or via "EasyX2" desktop/mobile app
- Password protected programmable user and control parameters
- EasySet access over TCP/IP for configuration (Wi-Fi interface required)

### Applications

- Differential pressure control, clean room
- Ventilation control
- Temperature control
- Air humidifier and dehumidifier
- Motion detection action

### Safety



#### **DANGER! Safety advice**

This device is for use as an operating controller or transmitter. It is not a safety device. Where a device failure could endanger human life and property, it is the responsibility of the client, installer and system designer to add additional safety devices to prevent such a device failure. Ignoring specifications and local regulations may cause equipment damage and endangers life and property. Tampering with the device and misapplication will void warranty.

---

## Types and Ordering

### Static Pressure Sensor

| Product Name                | Product No. | Option       | Range                                | AO1 | AO2 | AO3 |
|-----------------------------|-------------|--------------|--------------------------------------|-----|-----|-----|
| SRD2-THP2-411.103-OPIR-MOD  | 40-300268   | MODBUS RTU   | ± 125 Pa (± 0.5 in H <sub>2</sub> O) | T.  | H   | P   |
| SRD2-THP2-411.103-TOPIR-MOD | 40-000321   | MODBUS RTU   | ± 125 Pa (± 0.5 in H <sub>2</sub> O) | T.  | H   | P   |
| SRD2-THP2-411.103-TOPIR-BAC | 40-000322   | BACnet MS/TP | ± 125 Pa (± 0.5 in H <sub>2</sub> O) | T.  | H   | P   |

### Dynamic Pressure Sensor

| Product Name                 | Product No. | Option     | Range                                | AO1 | AO2 | AO3 |
|------------------------------|-------------|------------|--------------------------------------|-----|-----|-----|
| SRD2-THP2-411.103-OPIR-MOD-D | 40-300327   | MODBUS RTU | ± 100 Pa (± 0.4 in H <sub>2</sub> O) | T.  | H   | P   |

Description

T = Temperature sensor  
H = Humidity sensor  
P = Differential pressure sensor  
OP = With color display and touch buttons  
TOP = 3.5 in color display with capacitive touch  
IR = IR (PIR) sensor for motion detection  
MOD = Communication with Modbus RTU or ASCII

Common to all devices are:

- 4 universal configurable control loops
- 1 digital output (DO1) low voltage relay
- 3 analogue outputs (AO) 0...10 VDC
- 1 active input 0...10 VDC (UI8)

AO1, AO2 and AO3 are the analogue outputs of the controller/transmitter. The device is pre-programmed and works as a transmitter. The sensors are assigned to the analogue outputs according to the table.

### Accessories

| Product Name                       | Product No. | Description  |
|------------------------------------|-------------|--|
| <i>Pressure probe and tube</i>     |             |  |
| AMP-1                              | 40-510087   | Differential pressure probes with 0.5 m tube Ø 6 mm  |
| <i>Communication</i>               |             |  |
| AEC-USB-01                         | 40-500046   | USB to RS-485 converter cable kit used for EasySet tool. Not needed for -WIM or -WIB type  |
| <i>Memory</i>                      |             |  |
| AEC-PM2                            | 40-500130   | Plug-In memory module for saving and fast copying of parameter sets  |
| <i>External Operation Terminal</i> |             |  |
| OPT1-FA-TNV-VC                     | 40-500136   | A large range of external operation terminals may be found on our website <a href="http://www.vectorcontrols.com">www.vectorcontrols.com</a> . All -VC type operation terminals work with this controller. |
| OPT1-FA-HTNV-VC                    | 40-500135   |  |
| OPA2-VC                            | 40-500007   |  |
| OPA2-2T-VC                         | 40-500047   |  |
| OPA2-2HT-VC                        | 40-500023   |  |
| OPF2-2T-VC                         | 40-500159   |  |
| OPF2-2TH-VC                        | 40-500158   |  |

**Technical specifications**

|                                      |  |   |
|--------------------------------------|--|---|
| <b>Power supply</b>                  | Power requirements   | 24 VAC ±10%, 50/60 Hz, 15...34 VDC<br>SELV to HD 384, Class II, 48VA max  |
|                                      | Power consumption  | Max. 5 VA   |
| <b>Electrical connection</b>         | Power, I/O   | Push-In terminal for wire 0.25...1.3 mm <sup>2</sup> (AWG 24...16)        |
|                                      | COM-Module (blue 3P-plug)  | Detachable screw terminal for wire 0.34...2 mm <sup>2</sup> (AWG 22...14) |
|                                      | OP-connector (black 4P-plug)   | Detachable screw terminal for wire 0.1...1.3 mm <sup>2</sup> (AWG 28-16)  |
| <b>Temperature / Humidity Sensor</b> | Temperature sensor   | -T  |
|                                      | Measuring accuracy   | See Figure 2 in section Sensors   |
|                                      | Repeatability  | ± 0.1°C ( ± 0.2°F)  |
|                                      | Humidity sensor  | -H  |
|                                      | Range  | 0...100% RH   |
|                                      | Measuring accuracy   | See Figure 1 in section Sensors   |
|                                      | Hysteresis   | ± 1%  |
|                                      | Repeatability  | ± 0.1%  |
| <b>Static Sensor</b>                 | Stability  | < 0.5% / year   |
|                                      | Static differential pressure sensor  | SRD2-THP2 (Ceramic)   |
|                                      |  | ± 125 Pa, (± 0.5 in H <sub>2</sub> O)                                     |
|                                      | Error band after zeroing   | < 1.25% FSS   |
|                                      | Stability over 1 year  | 0.1 FSS   |
| <b>Dynamic Sensor</b>                | Proof pressure (overload pressure)   | 7 kPa (1.0 psi)   |
|                                      | Burst pressure   | 20 kPa (2.9 psi)  |
|                                      | Dynamic differential pressure sensor   | SRD2-THP2-411.103-OPIR-MOD-D  |
|                                      | Pressure range   | ± 100 Pa, ± 0.4 in H <sub>2</sub> O                                       |
|                                      | Zero pressure offset accuracy  | Typ: ± 0.1 %FSS, Max. 0.2%FSS   |
|                                      | Span accuracy  | Typ: ± 0.4 %, Max. 0.75 % of reading                                      |
|                                      | Thermal effects on offset  | 5...55 °C: ± 0.2%FSS. 0...70 °C: ± 0.4 %FSS                               |
|                                      | Thermal effects on span  | 5...55 °C: ± 1 % 0...70 °C: ± 2.75% of reading                            |
|                                      | Proof pressure (overload pressure)   | 200 kPa (30 psi)  |
|                                      | Burst pressure   | 500 kPa (75 psi)  |
| <b>Infrared Sensor</b>               | Passive infrared sensor PIR  | Motion detection  |
|                                      | Detection angle  | 120° horizontal and vertical  |
|                                      | Detection range  | 5.0m max., horizontal and vertical  |
| <b>Signal Input</b>                  | Voltage input  | UI8 input   |
|                                      | Input signal   | 0...10 VDC  |
|                                      | Resolution   | 9.76 mV (10 bit)  |
|                                      | Impedance  | 98kΩ  |
| <b>Signal outputs</b>                | Analog outputs   | AO1, AO2, AO3   |
|                                      | Output signal  | 0...10 VDC  |
|                                      | Resolution   | 9.76 mV (10 bit)  |
|                                      | Maximum load   | Impedance: ≥1kΩ   |
|                                      | Relay outputs: AC Voltage (SPDT)   | 0...48 VAC, full-load current 1A  |
|                                      | DC Voltage   | 0...30 VDC, full-load current 1A  |
|                                      | Insulation strength between relays contacts and system electronics: between neighbouring contacts: | 500 VAC to EN 60 730-1<br>500 VAC to EN 60 730-1                          |
| <b>Display – OPIR - TOPIR</b>        | TFT display compact  | 1.44 in, 128 x 128 px   |
|                                      | Buttons  | 4 capacitive touch buttons  |
| <b>Connection to remote terminal</b> | TFT display full   | 3.5 in, 320 x 480 px<br>Capacitive touch display                          |
|                                      | Hardware interface   | RS485 in accordance with EIA/TIA 485                                      |
| <b>Environment</b>                   | Cabling  | Twisted pair (STP) cable  |
|                                      | Operation  | To IEC 721-3-3  |
| <b>Environment</b>                   | Climatic conditions  | class 3K5   |
|                                      | Temperature  | 0...50 °C (32...122 °F)   |
|                                      | Humidity   | <85 % RH non-condensing   |
|                                      | Transport & storage  | To IEC 721-3-2 and IEC 721-3-1  |
|                                      | Climatic conditions  | class 3K3 and class 1K3   |
|                                      | Temperature  | 0...50 °C (32...122 °F)   |
|                                      | Humidity   | <95 % RH non-condensing   |
|                                      | Mechanical conditions  | class 2M2   |

|                              |                            |   |                                       |
|------------------------------|----------------------------|---|---------------------------------------|
| <b>Standards</b>             | Degree of Protection       | IP30 to EN 60 529                               |                                       |
|                              | Pollution Class            | II (EN 60 730-1)                                |                                       |
|                              | Safety Class               | III (EN 60 730-1)                               |                                       |
|                              | Overtoltage Category       | II (EN 60 730-1)                                |                                       |
| <b>General</b>               | Material                   | Flame retardant PC+ABS plastic (UL94 class V-0) |                                       |
|                              | Dimensions (H x W x D)     | -OPIR   | 115 x 90 x 24 mm (3.5 x 4.5 x 0.9 in) |
|                              |                            | -TOPIR  | 115 x 90 x 28 mm (3.5 x 4.5 x 1.1 in) |
|                              | Weight (including package) | SRD2-THPx-411.103-OPIR-COM:                     | 202 g (7.1 oz)                        |
| SRD2-THPx-411.103-TOPIR-COM: |                            | 242 g (8.5 oz)                                  |                                       |

**Technical specification for serial communication, -MOD and -BAC types**

|                      |  |  |  |
|----------------------|--|--|--|
| <b>Network</b>       | Hardware interface                       | RS485 in accordance with EIA/TIA 485   |  |
|                      | Max nodes per network                    | 128  |  |
|                      | Max nodes per segment                    | 64 (Vector devices only)   |  |
|                      | Conductors                               | Shielded Twisted Pair (STP) cable  |  |
|                      | Impedance                                | 100 - 130 ohm  |  |
|                      | Nominal capacitance                      | 100 pF/m 16 pF/ft. or lower  |  |
|                      | Galvanic isolation                       | The communication circuitry is isolated  |  |
|                      | Line termination                         | A line termination resistance (120 ohm) shall be connected between the terminals (+) and (-) of the furthestmost node of the network |  |
|                      | Network topology                         | Daisy chain according EIA/TIA 485 specifications   |  |
|                      | Recommended maximum length per chain     | 1200 m (4000 ft.)  |  |
| <b>Modbus (-MOD)</b> | Communication standard                   | Modbus ( <a href="http://www.modbus.org">www.modbus.org</a> )  |  |
|                      | Default setting                          | 19200 baud rate, RTU 8 data bits, 1 even parity bit, 1 stop bit  |  |
|                      | Communication speed                      | 4800, 9600, 19200, 38400   |  |
|                      | Protocol: Data bits<br>Parity – stop bit | RTU - 8 data bits, ASCII – 7 data bits, no parity – 2 stops, even or odd parity – 1 stop   |  |
| <b>BACnet (-BAC)</b> | Communication standard                   | BACnet MS/TP over RS485<br>BTL tested and listed B-ASC   |  |
|                      | Communication speed                      | 9600, 19200, 38400, 57600, 76800, 115200   |  |

**Technical specification for TCP/IP communication –WIM and -WIB types**

|                          |                        |  |  |
|--------------------------|------------------------|--|--|
| <b>Wi-Fi</b>             | Standards              | Wi-Fi Alliance<br>FCC/CE-RED/IC/TELEC/KCC/SRRC/NCC<br>802.11 b/g/n (802.11n up to 150 Mbps)<br>A-MPDU and A-MSDU aggregation and 0.4 µs guard interval support |  |
|                          | Frequency range        | 2.4 GHz ~ 2.5 GHz  |  |
|                          | Antenna                | Internal   |  |
|                          | Standard               | IEC 61158  |  |
| <b>Modbus TCP (-WIM)</b> | Communication protocol | Modbus TCP ( <a href="http://www.modbus.org">www.modbus.org</a> )  |  |
|                          | Transport Layer        | TCP/IP   |  |
|                          | TCP/IP Port            | 502  |  |
| <b>BACnet/IP (-WIB)</b>  | Communication standard | BACnet/IP<br>BTL tested and listed B-ASC   |  |
|                          | Transport Layer        | UDP  |  |
|                          | UDP Port               | 47808  |  |

**Product testing and certification**



Declaration of conformity

Information on the conformity of our products can be found on our website [www.vectorcontrols.com](http://www.vectorcontrols.com) on the corresponding product page under "Downloads".

## Mounting and Installation

---

### Mounting location

- Mount the controller on an easy accessible interior wall, approx. 1.5 m above the floor in an area of average temperature.
- The following mounting locations should be avoided:
  - Protect from direct exposure to sunlight
  - Do not mount near heat sources or other heat-generating devices
  - Do not mount in a wet or condensation prone environment
  - Areas with poor air circulation and niches or behind doors
  - In the direct influence area of ventilation and fans
  - For the types with wireless transmission (-WIM or -WIB), avoid locations that interfere with the radio signals, e.g. metal boxes or devices that generate electrical interferences.

**Important**

Observe local regulations!

---

### Sealing of cable entries

**Important**

All cable entries into the connection box must be sealed to prevent air drafts, which could otherwise affect the sensors in the device and prevent correct measurements!

---

### Installation instructions

For the SRD2-THP device:



Refer to the SRD2-THP installation sheet, document no. 70-00-1044 ([www.vectorcontrols.com](http://www.vectorcontrols.com)).

---

### Selection of actuators

#### Actuators

Choose modulating actuators with an input signal type of 0/2...10 VDC.  
3-point actuators with constant running time are recommended.

#### Binary auxiliary devices (e.g. pumps, fans, on/off valves, humidifiers, etc.)

Do not directly connect devices that exceed specified limits in technical specifications – observe startup current on inductive loads.

**Wiring and Connection**



**WARNING! Live Electrical Components**

During installation, testing, servicing and troubleshooting of Vector Controls products, it may be necessary to work with live electrical components. Have a qualified licensed electrician or other individual who has been properly trained in handling live electrical components perform these tasks. Failure to follow all electrical safety precautions when exposed to live electrical components could result in death or serious injury

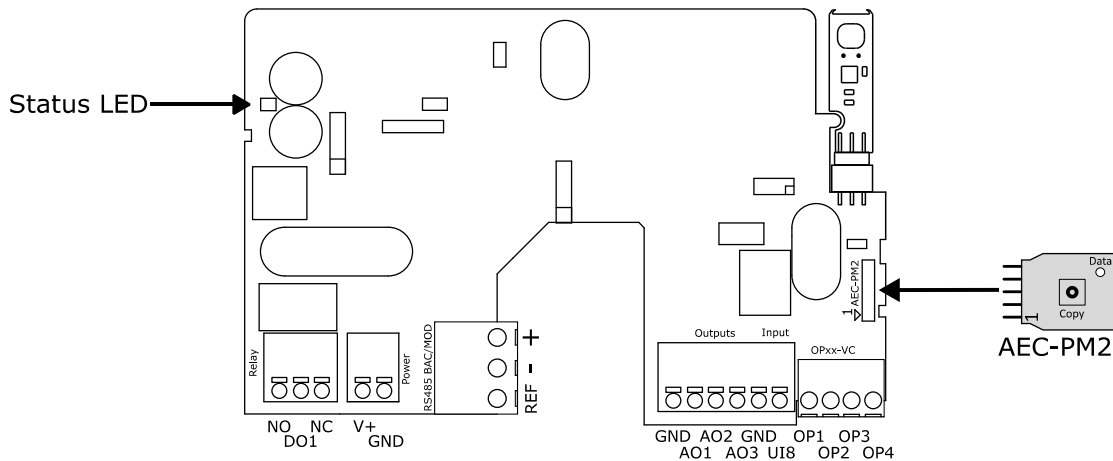
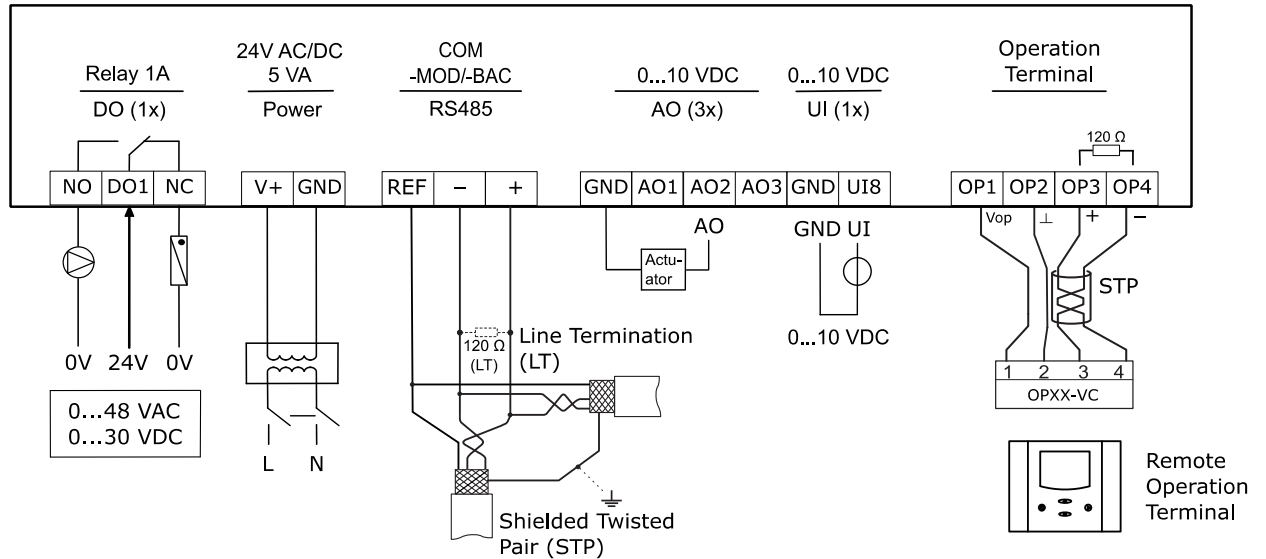

- GND** Power supply: 0V, -24VDC; common for power supply, analog in- and outputs
- V+** Power supply: 24VAC, +24VDC
- DO1** Binary outputs: Potential free low voltage relays contacts (see technical specification)
- AO** Analog output: 0...10 VDC
- UI8** Analog input: 0...10 VDC

**Note on how to use UI8 as DI (digital input)**



- Connect OP1 to Door contact to UI8
- Configure UI8 as 0-10 V input:
  - > 0V = 0% = contact open
  - > 10V = 100% = contact closed



**Important**

For the SRD2-OPIR type the following preset X2 input is assigned:

- UI7 = PIR sensor (passive infrared) for motion detection

## Wiring of communication (RS485)

### Wire type

An EIA-485 network shall use shielded, twisted-pair cable for data signaling with characteristic impedance between 100 and 130 ohms. Distributed capacitance between conductors shall be less than 100 pF per meter (30 pF per foot). Distributed capacitance between conductors and shield shall be less than 200 pF per meter (60 pF per foot). Foil or braided shields are acceptable.

### Maximum length

The maximum recommended length per segment is 1200 meters (4000 feet) with AWG 18 (0.82 mm<sup>2</sup> conductor area) cable.

## LED-indicators

### SRD2 LED

A status LED is located on the SRD2 board in the controller housing. During normal operation, the LED flashes once every 5 seconds. If there is an alarm or fault condition, it will flash every second.

For -P2 devices, the status LED is used as well to indicate 0-point calibration. Please see



The function of the system LED is explained in the X2 Engineering Manual, document no. 70-00-0737.

### Modbus LED (-MOD type)

The Modbus interface features a green LED and a red LED for indication of traffic on the RS-485 bus. The green LED is lit when an incoming packet is received, and the red LED is lit when an outgoing packet is transmitted to the bus. At power-up, both LEDs blink twice simultaneously as a sign of the boot process being completed. A constantly lit LED serves as an indication of a fault condition in the reception or sending process.

### BACnet LED (-BAC type)

The BACnet interface features a green LED and a red LED for indication of traffic on the RS-485 bus. The green LED is lit when an incoming packet is received, and the red LED is lit when an outgoing packet is transmitted to the bus. At power-up, both LEDs blink twice simultaneously as a sign of the boot process being completed. A constantly lit LED serves as an indication of a fault condition in the reception or sending process.

## Signal sound

### SRD2 Buzzer

The SRD2's buzzer can be activated in the event of an alarm.



The function of the signal sound is explained in the X2 Engineering Manual, document no. 70-00-0737.

## Dimensions, mm (inch)

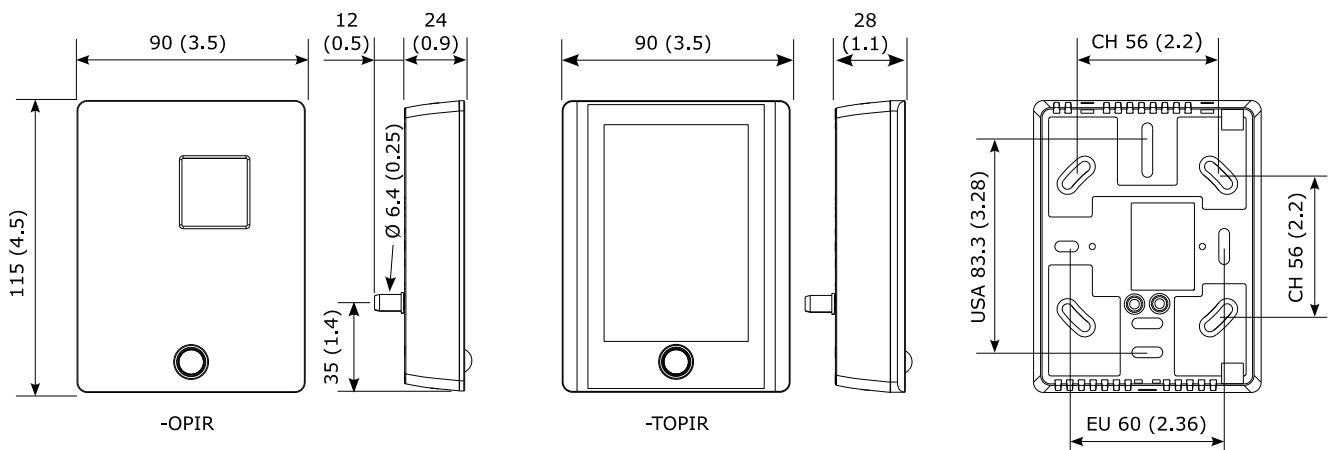

**Sensors**

**Temperature & Humidity from RH sensor in -TH type**

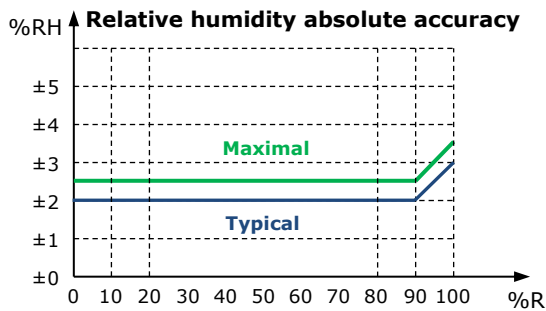

Figure 1: Typical and maximal RH accuracy at 25°C (77°F)

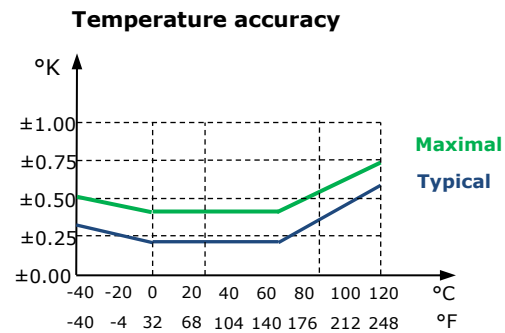

Figure 2: Typical and maximal temperature accuracy

**Pressure sensor**

The sensor measures the pressure using a ceramic or microthermal flow (-D) measuring element. The measured value is temperature-compensated and calibrated. A microcontroller scans the pressure ten times per second, calculates the average value based on the preset number of measured values, and generates an output value depending on the preset minimum and maximum pressure values.

**Altitude correction for dynamic pressure sensors**

Dynamic pressure sensors are affected by ambient atmospheric pressure, which decreases with altitude. To ensure accurate pressure, velocity or airspeed measurements, the sensor output must be corrected for the operating altitude. This can be achieved by setting the altitude parameter UP 29. Without this correction, measurements may contain significant errors at higher elevations.

**Zero-calibration of static pressure sensor**

With the "Zero-calibration" function, it is possible to zero out a sensor offset. The "Zeroing" value is subtracted from the measurement at every sensor read. This allows for effective measuring the differential pressure in a system.

**i** For optimal accuracy, we recommend repeating the "Zeroing" of the pressure sensor every 12 months. Zeroing is not required for dynamic sensors.

1. Open the SRD2 cover and power up the device.
2. Short press "ZERO" button on P-Sensor board.
3. For -P2 products: Status LED starts blinking.  
For -P3 products: LED on P-Sensor board starts blinking.
4. Press "ZERO" button again.
5. After "Zeroing" is successful, LED lights up constant for 5 seconds.  
If Zeroing is not successful (difference too large, signal not constant, etc) The LED blinks for 10 seconds in 1 second interval.

Note: If "ZERO" button is not pressed again, the sensor will return to normal operation after 10 seconds.

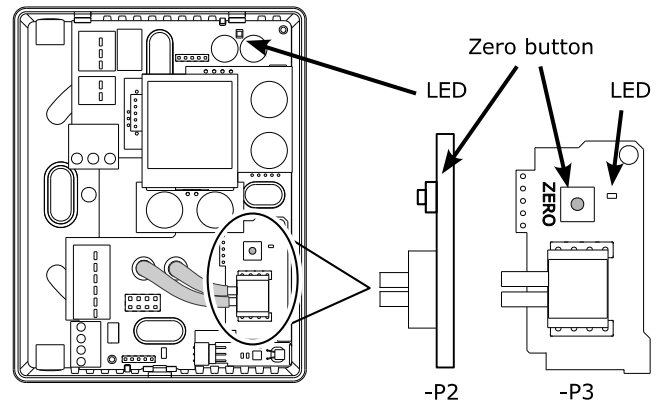

**i** For details on how to open the device, consult the SRD2-THP installation sheet, document no. 70-00-1044 ([www.vectorcontrols.com](http://www.vectorcontrols.com)).

**Passive infrared (PIR) sensor in -IR type**

The 120° detection range of the PIR sensor of a wall mounted SRD2 is shown below.

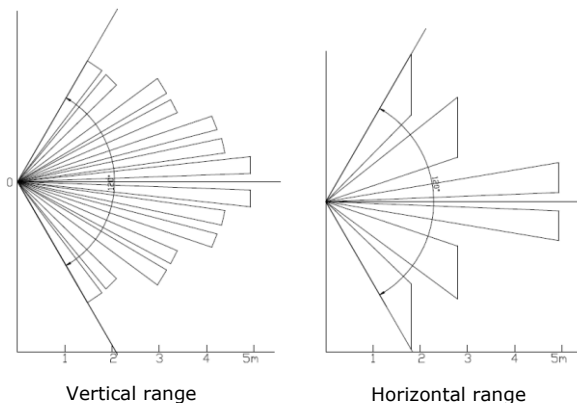

## Operation and Configuration

### Documentation

This controller uses the latest generation X2 operating system. Detailed operation instructions for all devices equipped with this operating system can be found on our website [www.vectorcontrols.com](http://www.vectorcontrols.com).

Also available are programming instructions for technicians and an application database.



More information on the X2 operating system can be found on our website [www.vectorcontrols.com](http://www.vectorcontrols.com) under "X2 Controls".

### Configuration

#### Configuring with EasySet (free PC application)

We recommend to use the PC and the EasySet tool to easily configure the SRD2 to your needs. Connect the PC with the EasySet tool via the AEC-USB converter or use the PC's Wi-Fi communication to connect to the SRD2 (SRD2-WIM /-WIB types only). Refer to the SRD2 installation sheet for connection details and the X2 Engineering Manual for configuration details.



**The device can be fully configured and commissioned using the EasySet program.**

EasySet may be downloaded free of charge from our website [www.vectorcontrols.com](http://www.vectorcontrols.com).

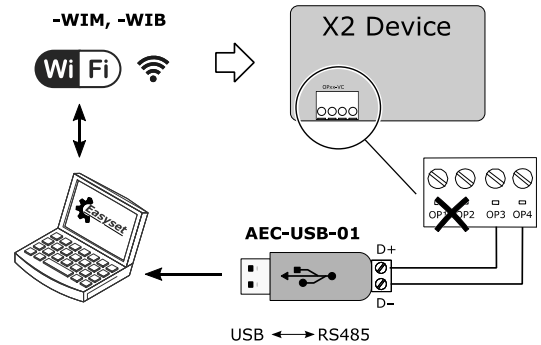

#### Configuring with operation terminal

Alternatively, the SRD2 can also be configured via an external operation terminal (OPT1-xx, OPA2-xx) to your needs. Connect the terminal to the OPxx-VC connectors on the SRD2. Refer to the SRD2 installation sheet and the X2 Engineering Manual for configuration details.



For more information on configuration, refer to the X2 Engineering Manual, document no. 70-00-0737.

### Copy configuration to other SRD2 devices

Complete parameter sets may be copied using the accessory AEC-PM2 or exchanged with a PC using the EasySet tool and an RS485-USB converter or via Wi-Fi communication.

#### Copy configuration with the AEC-PM2 (plug-in memory)

To load the configuration into the AEC-PM2, we recommend using the EasySet "Copy Memory" function. Alternatively, an external operation terminal can be used to instruct the SRD2 to load the configuration into the AEC-PM2 (see X2 Engineering Manual and SRD2 Installation Sheet).

To copy the configuration to another SRD2, simply connect the AEC-PM2 plug-in memory to the SRD2 and press the copy button (see the SRD2 installation sheet for connection details).

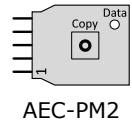

#### Copy configuration with EasySet (free PC application)

To copy the configuration to another SRD2 device, connect the PC with the EasySet tool via the AEC-USB converter or use the PC's Wi-Fi communication to connect to the SRD2 (for SRD2-WIM /-WIB types only). Refer to the SRD2 installation sheet for connection details.



For more information on configuration, refer to the X2 Engineering Manual, document no. 70-00-0737.

**Documentation overview**

| Document Type  | Document No. | Description  |
|--|--------------|--|
| SRD2-THP Data Sheet  | 70-00-0979   | Product data sheet (this document)                                 |
| SRD2-THP Install Sheet                                     | 70-00-1044   | Mounting and installation manual                                   |
| X2 Operations Manual touch button display                  | 70-00-0994   | Operations instructions of X2 system with touch button and display |
| X2 Web Interface operation manual                          | 70-00-0952   | Operations instructions of X2 Web interface                        |
| X2 Engineering Manual                                      | 70-00-0737   | Guidelines for configuring the X2 system                           |
| X2 Modbus Communication Module (-MOD type)                 | 70-00-0290   | Setup and configuration manual Modbus (no Modbus TCP)              |
| X2 Modbus Communication Module (-WIM type)                 | 70-00-0925   | Setup and configuration manual Modbus TCP                          |
| X2 BACnet Communication Module (-BAC type)                 | 70-00-0218   | Setup and configuration manual BACnet (no BACnet/IP)               |
| X2 BACnet/IP Communication Module (-WIB type)              | 70-00-0899   | Setup and configuration manual BACnet/IP                           |
| X2 Wi-Fi / Ethernet Communication Manual (-WIM, -WIB type) | 70-00-0900   | Setup and configuration manual TCP/IP                              |

Note: The above list is not complete. The documents on the website are relevant.

## BACnet (PICS)

### Protocol Implementation Conformance Statement for BACnet MS/TP and BACnet IP network

 The following is only valid for products with the **-BAC and -WIB** option.

Vendor Name: Vector Controls  
 Product Name: SRD2 Controls series  
 SRD2 product description: The SRD2 communicating BACnet controllers are designed as universal controls equipment suitable for a large number of applications. They may be used in zoning and other applications which are monitored by a BACnet MS/TP network.

#### ▲ Supported BACnet Interoperability Blocks (BIBB)

The BACnet interface conforms to the B-ASC device profile (BACnet Application Specific Controller). The following BACnet Interoperability Building Blocks (BIBB) is supported.

| BIBB                | Type              | Name                             |
|---------------------|-------------------|----------------------------------|
| DS-RP-B             | Data sharing      | Read property - B                |
| DS-RPM-B            | Data sharing      | Read property multiple - B       |
| DS-WP-B             | Data sharing      | Write property - B               |
| <b>DS-COV-B *1)</b> | Data sharing      | Change of value - B              |
| DM-DCC-B            | Device management | Device communication Control - B |
| DM-DDB-B            | Device management | Dynamic device binding - B       |
| DM-DOB-B            | Device management | Dynamic object binding - B       |
| DM-TS-B             | Device management | Time synchronisation - B         |
| DM-UTC-B            | Device management | UTC Time synchronisation - B     |
| DM-RD-B             | Device management | Reinitialize device - B          |

\*1) With -BAC, a maximum of 5 COV objects can be activated at the same time. This limitation does not apply to -WIB.

#### ▲ Supported standard BACnet application services

- ReadProperty
- ReadPropertyMultiple
- WriteProperty
- DeviceCommunication (password protected)
- I-Am
- I-Have
- TimeSynchronisation
- UTCTimeSynchronisation
- ReinitializeDevice ("cold" or "warm") (password protected)

#### ▲ Supported standard Object types

- Device
- Analog input
- Analog value
- Binary value
- Multi-state Value

## X2 Functional Scope

The controller has the following X2 functions and elements:

| Group | Modules    | QTY | Description  |
|-------|------------|-----|--|
| UP    |            |     | User and display parameters  |
| UI    | 01U to 06U | 6   | Sensor inputs for temperature, humidity, CO2, VOC and dust particle sensor (PMxx)                                |
|       | 07U        | 1   | PIR sensor as motion detector (only SRD2-OPIR type)  |
|       | 08U        | 1   | Active input 0...10 VDC  |
|       | 09U to 12U | 4   | Virtual inputs for operation terminals, bus modules or special functions   |
| AL    | 1AL to 8AL | 8   | Alarm conditions   |
| LP    | 1L to 4L   | 4   | Control loops  |
| Ao    | 1A to 3A   | 3   | Analog outputs for 0...10 VDC  |
| FAN   | 1F         | 1   | Fan or lead lag modules, 1 to 3 fan speeds, up to 3 switching lead-lag stages each                               |
| do    | 1d         | 1   | Binary output with a normally open and a normally closed (SPDT) relays contact                                   |
| FU    | 1FU        | 1   | Remote Enable: Activation of the controller based on signal and alarm conditions                                 |
|       | 2FU        | 1   | Change Operation Mode: Switching occupied and unoccupied with control signals                                    |
|       | 3FU        | 1   | Heat/Cool Change: Switching heating and cooling based on a control signal  |
|       | 4FU        | 1   | Setpoint Compensation: Summer/winter compensation of setpoint  |
|       | 5FU        | 1   | Economizer (free heating or cooling due to the condition of outside and room air)                                |
| Co    |            |     | Communication (if a communication module is available)   |
| COPY  |            |     | Copying complete parameter sets between run, default and external memory with up to 4 memory locations (AEC-PM2) |

Empty page

## **Smart Sensors and Controls Made Easy!**

### **Quality - Innovation – Partnership**

Vector Controls GmbH  
Switzerland

[info@vectorcontrols.com](mailto:info@vectorcontrols.com)  
[www.vectorcontrols.com](http://www.vectorcontrols.com)

