



SRD2

SRD2-TOPIR

SRD2-OPIR



Universal Programmable Indoor Controller and Transmitter SRD2

The SRD2 is a wall-mounted programmable controller and transmitter with communication capabilities. Each control loop may use 2 PI sequences and multiple binary stages. The SRD2 comes with a built-in isolated RS485 communication interface that allows peer-to-peer communication with an operation terminal such as OPT1-(2TH)-VC. An optional built-in 3.5 in touch screen or a color display with touch buttons provide a perfect and flexible way to interact with the user.

Complete parameter sets may be copied by use of an accessory called AEC-PM2 or exchanged with a PC and the EasySet program using an RS485-USB converter or via Wi-Fi. The SRD2 uses the Vector Controls universal and flexible X2 operating system and is preconfigured according to this documentation.

Functions

- Four universally configurable control loops:
 - Functions for dehumidifying, set point shift and cascade control
 - Multiple auxiliary functions: heat-cool auto changeover, automatic enable, set point compensation
 - Free heating and cooling with economizer function based on enthalpy or temperature
 - Differential, averaging, min and max functions, enthalpy and dew point calculations
 - Transmitter function for sensors and set points
- Measures:
 - Temperature
 - Humidity
 - CO2
 - VOC air quality
 - Dust particles (Particulate matter PM1.0, PM2.5, PM10)
 - Formaldehyde (HCHO)
- A passive infrared sensor (-PIR type) which can be used for motion detection (occupied / unoccupied)
- 1.44 in color display with backlight and touch button operation (-OP type)
- 3.5 in capacitive touch color display (-TOP-type)
- Built-in humidity and temperature sensor (-TH type), CO2 sensor (-C type), VOC sensor (-Q type), dust particle sensor (-D type), Formaldehyde sensor (-F type)
- 3 analogue voltage outputs (VDC) and one relay with a normally open and a normally closed contact (SPDT)
- 8 freely assigned alarm conditions, selectable state of outputs on alarm condition and alarm sound
- Serial Modbus RTU/ASCII or BACnet MS/TP via isolated RS485
- Modbus TCP or BACnet/IP via Wi-Fi
- Webserver for SRD2 operation from computer / mobile device or via "EasyX2" desktop/mobile app
- Password protected programmable user and control parameters
- EasySet access over TCP/IP for configuration (Wi-Fi interface required)

Applications

- Ventilation control
- Temperature control
- Air humidifier and dehumidifier
- CO2 / VOC / Dust particle / Formaldehyde air quality control
- Differential pressure control, clean room
- Motion detection action

Safety



DANGER! Safety advice

This device is for use as an operating controller or transmitter. It is not a safety device. Where a device failure could endanger human life and property, it is the responsibility of the client, installer and system designer to add additional safety devices to prevent such a device failure. Ignoring specifications and local regulations may cause equipment damage and endangers life and property. Tampering with the device and misapplication will void warranty.

Ordering

Ordering SRD2 without display

Product Name	Product No.	SI1	SI2	SI3	SI4	SI5	SI6	AO1	AO2	AO3
SRD2-TH-411.103	40-300255	T	H					T	H	-
SRD2-TH-411.103-MOD	40-300216	T	H					T	H	-
SRD2-TH-411.103-BAC	40-300217	T	H					T	H	-
SRD2-TH-411.103-WIM	40-300218	T	H					T	H	-
SRD2-TH-411.103-WIB	40-300219	T	H					T	H	-
SRD2-C-411.103	40-300271			C				C		
SRD2-C-411.103-MOD	40-300270			C				C		
SRD2-D-411.103-MOD	40-300269	D	PM1.0	PM10				D	PM1.0	PM10
SRD2-THC-411.103	40-300252	T	H	C				T	H	C
SRD2-THC-411.103-MOD	40-300222	T	H	C				T	H	C
SRD2-THC-411.103-BAC	40-300223	T	H	C				T	H	C
SRD2-THC-411.103-WIM	40-300224	T	H	C				T	H	C
SRD2-THC-411.103-WIB	40-300225	T	H	C				T	H	C
SRD2-THD-411.103	40-300251	T	H		D			T	H	D
SRD2-THCQ-411.103-MOD	40-300250	T	H	C		Q		T	H	C
SRD2-THCD-411.103-MOD	40-300273	T	H	C	D			T	H	C
SRD2-THCQ-411.103-MOD	40-300250	T	H	C		Q	CO2eq	T	H	C
SRD2-THCQD-411.103-MOD	40-300237	T	H	C	D	Q	CO2eq	T	H	C
SRD2-THCQD-411.103-BAC	40-300238	T	H	C	D	Q	CO2eq	T	H	C
SRD2-THCQD-411.103-WIM	40-300239	T	H	C	D	Q	CO2eq	T	H	C
SRD2-THCQD-411.103-WIB	40-300240	T	H	C	D	Q	CO2eq	T	H	C
SRD2-D-411.103	40-300251	D	PM 1.0	PM 10				D	PM1.0	PM10
SRD2-THCQDF-411.103-MOD	40-300299	T	H	C	Q	D	F	T	H	C

Description

T	= Temperature sensor
H	= Humidity sensor
C	= CO2 sensor
D	= Dust particle sensor PM2.5
Q	= VOC air quality sensor
CO2eq	= CO2 equivalent measured with VOC sensor
F	= Formaldehyde (HCHO) sensor
OP	= 1.44 in color display and touch buttons
TOP	= 3.5 in color display with capacitive touch
IR	= IR (PIR) sensor for motion detection
MOD	= Communication with Modbus RTU or ASCII
BAC	= Communication with BACnet MS/TP
WIM	= Communication with Modbus TCP over Wi-Fi
WIB	= Communication with BACnet IP over Wi-Fi

Common to all devices are:

- 4 universal configurable control loops
- 1 digital output (DO1) low voltage relay
- 3 analogue outputs (AO) 0...10 VDC
- 1 active input 0...10 VDC (UI8)

Products with CO2/VOC and display (-OPIR):

- Air quality bar enabled
- Else disabled

Products with OPIR and TOPIR:

- UI7 as Motion detection input (with 30s auto switch off time) enabled -> Mapped to DO1
- Else DO1 disabled

AO1, AO2 and AO3 are the analogue outputs of the controller/transmitter. The device is pre-programmed and works as a transmitter. The sensors are assigned to the analogue outputs according to the table.

Ordering SRD2 with small display -OPIR

Product Name	Product No.	SI1	SI2	SI3	SI4	SI5	SI6	AO1	AO2	AO3
SRD2-TH-411.103-OPIR	40-300256	T	H					T	H	-
SRD2-TH-411.103-OPIR-MOD	40-300253	T	H					T	H	-
SRD2-TH-411.103-OPIR-BAC	40-300254	T	H					T	H	-
SRD2-TH-411.103-OPIR-WIM	40-300220	T	H					T	H	-
SRD2-TH-411.103-OPIR-WIB	40-300221	T	H					T	H	-
SRD2-C-411.103-OPIR	40-300272			C				C		
SRD2-D-411.103-OPIR	40-300275	D	PM1.0	PM10				D	PM1.0	PM10
SRD2-THC-411.103-OPIR	40-300226	T	H	C				T	H	C
SRD2-THC-411.103-OPIR-MOD	40-300227	T	H	C				T	H	C
SRD2-THC-411.103-OPIR-BAC	40-300228	T	H	C				T	H	C
SRD2-THC-411.103-OPIR-WIM	40-300229	T	H	C				T	H	C
SRD2-THC-411.103-OPIR-WIB	40-300230	T	H	C				T	H	C
SRD2-THQ-411.103-OPIR	40-300231	T	H			Q	CO2eq	T	H	Q
SRD2-THQ-411.103-OPIR-MOD	40-300232	T	H			Q	CO2eq	T	H	Q
SRD2-THQ-411.103-OPIR-BAC	40-300233	T	H			Q	CO2eq	T	H	Q
SRD2-THCD-411.103-OPIR-MOD	40-300274	T	H	C	D			T	H	C
SRD2-THCQD-411.103-OPIR-MOD	40-300234	T	H	C	D	Q	CO2eq	T	H	C
SRD2-THCQD-411.103-OPIR-BAC	40-300235	T	H	C	D	Q	CO2eq	T	H	C
SRD2-THCQD-411.103-OPIR-WIM	40-300215	T	H	C	D	Q	CO2eq	T	H	C
SRD2-THCQD-411.103-OPIR-WIB	40-300236	T	H	C	D	Q	CO2eq	T	H	C

Ordering SRD2 with large display -TOPIR

Product Name	Product No.	SI1	SI2	SI3	SI4	SI5	SI6	AO1	AO2	AO3
SRD2-TH-411.103-TOPIR	40-000301	T	H					T	H	-
SRD2-TH-411.103-TOPIR-MOD	40-000302	T	H					T	H	-
SRD2-TH-411.103-TOPIR-BAC	40-000303	T	H					T	H	-
SRD2-TH-411.103-TOPIR-WIM	40-000304	T	H					T	H	-
SRD2-TH-411.103-TOPIR-WIB	40-000305	T	H					T	H	-
SRD2-THC-411.103-TOPIR	40-000306	T	H	C				T	H	C
SRD2-THC-411.103-TOPIR -MOD	40-000307	T	H	C				T	H	C
SRD2-THC-411.103-TOPIR -BAC	40-000308	T	H	C				T	H	C
SRD2-THC-411.103-TOPIR-WIM	40-000309	T	H	C				T	H	C
SRD2-THC-411.103-TOPIR-WIB	40-000310	T	H	C				T	H	C
SRD2-THCQD-411.103-TOPIR-MOD	40-000311	T	H	C	D	Q	CO2eq	T	H	C
SRD2-THCQD-411.103-TOPIR-BAC	40-000312	T	H	C	D	Q	CO2eq	T	H	C
SRD2-THCQD-411.103-TOPIR-WIM	40-000313	T	H	C	D	Q	CO2eq	T	H	C
SRD2-THCQD-411.103-TOPIR-WIB	40-000314	T	H	C	D	Q	CO2eq	T	H	C

Ordering of pre-configured SRD2 models

For a detailed description of how the pre-configured models work, see chapter "Pre-Configured Variants" on page 12.

Product Name	Product No.	Description	AO1	AO2	AO3	DO1
<i>Pre-Configured SRD2-TH Models (-Wx)</i>						
SRD2-TH-411.103-W8	40-300255-8	W8 = Dew point sensor, ISO unit °C W28 = Dew point sensor, Imperial unit °F W9 = Enthalpy sensor, ISO unit kJ/kg W29 = Enthalpy sensor, Imperial unit BTU/lb	See chapter "Pre-Configured Variants" on page 12			
SRD2-TH-411.103-W28	40-300255-28					
SRD2-TH-411.103-W9	40-300255-9					
SRD2-TH-411.103-W29	40-300255-29					
SRD2-TH-411.103-OPIR-W8	40-300256-8					
SRD2-TH-411.103- OPIR-W28	40-300256-28					
SRD2-TH-411.103- OPIR-W9	40-300256-9					
SRD2-TH-411.103- OPIR-W29	40-300256-29					

Accessories

Product Name	Product No.	Description
<i>Sensors</i>		
SRA-Tn10	40-200005	A large range of external sensors may be found on our website www.vectorcontrols.com . All Vector Controls type NTC Sxx-Tn10 temperature sensors work with this controller.
SDB-Tn10-12-1	40-200124	
SDB-Tn10-20-1	40-200133	
SOD-Tn10-x	40-200108	
S-Tn10-2	40-200001	
S-Tn10-6	40-200142	
SC-Tn10-2	40-200095	
SD-Tn10-12-1	40-200002	
SD-Tn10-20-1	40-200003	
AMI-S10	40-51xxxx	Stainless steel immersion pockets for temperature probes
<i>Communication</i>		
AEC-USB-01	40-500046	USB to RS-485 converter cable kit used for EasySet tool. Not needed for -WIM or -WIB type
<i>Memory</i>		
AEC-PM2	40-500130	Plug-In memory module for saving and fast copying of parameter sets
<i>External Operation Terminal</i>		
OPT1-FA-TNV-VC	40-500136	A large range of external operation terminals may be found on our website www.vectorcontrols.com . All -VC type operation terminals work with this controller.
OPT1-FA-HTNV-VC	40-500135	
OPA2-VC	40-500007	
OPA2-2T-VC	40-500047	
OPA2-2HT-VC	40-500023	
OPF2-2T-VC	40-500159	
OPF2-2TH-VC	40-500158	

Technical specifications

Power supply	Power requirements	24 VAC ±10%, 50/60 Hz, 15...34 VDC SELV to HD 384, Class II, 48VA max	
	Power consumption	Max. 5 VA	
	Electrical connection	Screw terminal connectors for wire 0.52...1.3 mm ² (AWG 20...16)	
Built-in sensors	Temperature sensor		
	Measuring accuracy (typ.)	± 0.2°C (± 0.4°F) - See Figure 2 in section <i>Sensors</i>	
	Repeatability	± 0.1°C (± 0.2°F)	
	-TH	Humidity sensor	Capacitive sensing element
		Range	0...100% RH
		Measuring accuracy (typ.)	± 1.8% RH - See Figure 1 in section <i>Sensors</i>
		Hysteresis	± 1%
		Repeatability	± 0.1%
		Stability	< 0.5% / year
	-C	CO2 sensor	Photoacoustic NDIR sensor with automatic baseline correction
		Measuring range	0 - 5000 ppm vol.
		Response time (63%)	1 Minute
		Repeatability	± 10 ppm typical
		Accuracy	400...999 ppm ± 50 ppm ± 2.5% of measured value 1000....1999 ppm ± 50 ppm ± 3% of measured value 2000....5000 ppm ± 40 ppm ± 5% of measured value
-Q	VOC sensor	MEMS metal oxide sensor with ABC automatic background calibration algorithm	
	Sensing range Module	0 – 100% AQI (air quality index), 0 – 500 TVOC index points Automatic baseline correction (24 h)	
-D	Dust particle sensor	Laser light scattering sensor	
	Particle size range	0.3µm...10µm	
	Measurement range	0...5000µg/m ³	
	Resolution	1 µg/m ³	
	Accuracy	PM1.0 / PM2.5 configuration: 0...100 µg/m ³ = 10µg/m ³ , 101...500µg/m ³ = ±10% of value PM10 configuration: 0...100 µg/m ³ = 25µg/m ³ , 101...500µg/m ³ = ±25% of value	
-F	Formaldehyde (HCHO) sensor	Fuel cell electrochemical sensor	
	Measurement range	0...1000 µg/m ³	
	Resolution	1 µg/m ³	
	Accuracy	10% of reading	
	Service Life	3 years	
-IR	Passive infrared sensor PIR	UI7, Motion detection	
	Detection angle Detection range	120° horizontal and vertical 5 m max., horizontal and vertical	
Signal Input	Passive input RT/DI	UI8, resistive temperature sensor NTC or DI open contact	
	Passive temperature Range	NTC (Sxx-Tn10) 10kΩ@25°C -40...100 °C (-40...212 °F)	
Signal outputs	Analog outputs	AO1, AO2, AO3	
	Output signal	0...10 VDC	
	Resolution	9.76 mV (10 bit)	
	Maximum load	Impedance: ≥1kΩ	
	Relay outputs:	AC Voltage 0...48 VAC, full-load current 1A DC Voltage 0...30 VDC, full-load current 1A	
	Insulation strength between relays contacts and system electronics: between neighboring contacts:	500 VAC to EN 60 730-1 500 VAC to EN 60 730-1	
Display – OPIR	TFT display compact	1.44 in, 128 x 128 px	
	Buttons	4 capacitive touch buttons	
- TOPIR	TFT display full	3.5 in, 320 x 480 px Capacitive touch display	
Connection to remote terminal	Hardware interface	RS485 in accordance with EIA/TIA 485	
	Cabling	Twisted pair (STP) cable	
Environment	Operation	To IEC 721-3-3	
	Climatic conditions	class 3K5	
	Temperature	0...50 °C (32...122 °F)	
	Humidity	<85 % RH non-condensing	
	Transport & storage	To IEC 721-3-2 and IEC 721-3-1	
	Climatic conditions	class 3K3 and class 1K3	
Temperature	0...50 °C (32...122 °F)		
Humidity	<95 % RH non-condensing		
	Mechanical conditions	class 2M2	

Standards	Degree of Protection	IP30 to EN 60 529	
	Pollution Class	II (EN 60 730-1)	
	Safety Class	III (EN 60 730-1)	
	Overtoltage Category	II (EN 60 730-1)	
General	Material	Flame retardant PC+ABS plastic (UL94 class V-0)	
	Dimensions (H x W x D)	-OPIR	115 x 90 x 24 mm (3.5 x 4.5 x 0.9 in)
		-TOPIR	115 x 90 x 28 mm (3.5 x 4.5 x 1.1 in)
	Weight (including package)	SRD2-THCQD-411.103-OPIR-COM:	198 g (7.0 oz)
		SRD2-THCQD-411.103-TOPIR-COM:	238 g (8.4 oz)
		SRD2-THCQD-411.103-COM:	190 g (6.7 oz)
		SRD2-TH/THC/THQ-411.103-OPIR-COM:	176 g (6.2 oz)
		SRD2-TH/THC/THQ-411.103-TOPIR-COM:	216 g (7.6 oz)
SRD2-TH/THC/THQ-411.103-OPIR:		169 g (6.0 oz)	
SRD2-TH/THC/THQ-411.103-TOPIR:		209 g (7.4 oz)	
SRD2-TH/THC/THQ-411.103-COM:	168 g (5.9 oz)		

Technical specification for serial communication, -MOD and -BAC types

Network	Hardware interface	RS485 in accordance with EIA/TIA 485
	Max nodes per network	128
	Max nodes per segment	64 (Vector devices only)
	Conductors	Shielded Twisted Pair (STP) cable
	Impedance	100 - 130 ohm
	Nominal capacitance	100 pF/m 16 pF/ft. or lower
	Galvanic isolation	The communication circuitry is isolated
	Line termination	A line termination resistance (120 ohm) shall be connected between the terminals (+) and (-) of the furthest node of the network
	Network topology	Daisy chain according EIA/TIA 485 specifications
	Recommended maximum length per chain	1200 m (4000 ft.)
Modbus (-MOD)	Communication standard	Modbus (www.modbus.org)
	Default setting	19200 baud rate, RTU 8 data bits, 1 even parity bit, 1 stop bit
	Communication speed	4800, 9600, 19200, 38400
	Protocol: Data bits Parity – stop bit	RTU - 8 data bits, ASCII – 7 data bits, no parity – 2 stops, even or odd parity – 1 stop
BACnet (-BAC)	Communication standard	BACnet MS/TP over RS485 BTL tested and listed B-ASC
	Communication speed	9600, 19200, 38400, 57600, 76800, 115200



Technical specification for TCP/IP communication –WIM and -WIB types

Wi-Fi	Standards	Wi-Fi Alliance FCC/CE-RED/IC/TELEC/KCC/SRRC/NCC 802.11 b/g/n (802.11n up to 150 Mbps) A-MPDU and A-MSDU aggregation and 0.4 µs guard interval support
	Frequency range	2.4 GHz ~ 2.5 GHz
	Antenna	Internal
	Modbus TCP (-WIM)	Standard
BACnet/IP (-WIB)	Communication protocol	Modbus TCP (www.modbus.org)
	Transport Layer	TCP/IP
	TCP/IP Port	502
BACnet/IP (-WIB)	Communication standard	BACnet/IP BTL tested and listed B-ASC
	Transport Layer	UDP
	UDP Port	47808



Product testing and certification



Declaration of conformity

Information on the conformity of our products can be found on our website www.vectorcontrols.com on the corresponding product page under "Downloads".

Mounting and Installation

Mounting location

- Mount the controller on an easy accessible interior wall, approx. 1.5 m above the floor in an area of average temperature.
- The following mounting locations should be avoided:
 - Protect from direct exposure to sunlight
 - Do not mount near heat sources or other heat-generating devices
 - Do not mount in a wet or condensation prone environment
 - Areas with poor air circulation and niches or behind doors
 - In the direct influence area of ventilation and fans
 - For the types with wireless transmission (-WIM or -WIB), avoid locations that interfere with the radio signals, e.g. metal boxes or devices that generate electrical interferences.

**Important**

Observe local regulations!

Sealing of cable entries

**Important**

All cable entries into the connection box must be sealed to prevent air drafts, which could otherwise affect the sensors in the device and prevent correct measurements!

Installation instructions

For the SRD2-THP device:



Refer to the SRD2-THP installation sheet, document no. 70-00-1044 (www.vectorcontrols.com).

For all other SRD2 devices:



Refer to the SRD2 installation sheet, document no. 70-00-0859 (www.vectorcontrols.com).

Selection of sensors and actuators

Temperature sensors

Use Vector Controls NTC sensors to achieve maximum accuracy: SDB-Tn10-20 (duct), SRA-Tn10 (room), SDB-Tn10-20 + AMI-S10 as immersion sensor.

Actuators

Choose modulating actuators with an input signal type of 0/2...10 VDC.
3-point actuators with constant running time are recommended.

Binary auxiliary devices (e.g. pumps, fans, on/off valves, humidifiers, etc.)

Do not directly connect devices that exceed specified limits in technical specifications – observe startup current on inductive loads.

Wiring and Connection



WARNING! Live Electrical Components

During installation, testing, servicing and troubleshooting of Vector Controls products, it may be necessary to work with live electrical components. Have a qualified licensed electrician or other individual who has been properly trained in handling live electrical components perform these tasks. Failure to follow all electrical safety precautions when exposed to live electrical components could result in death or serious injury

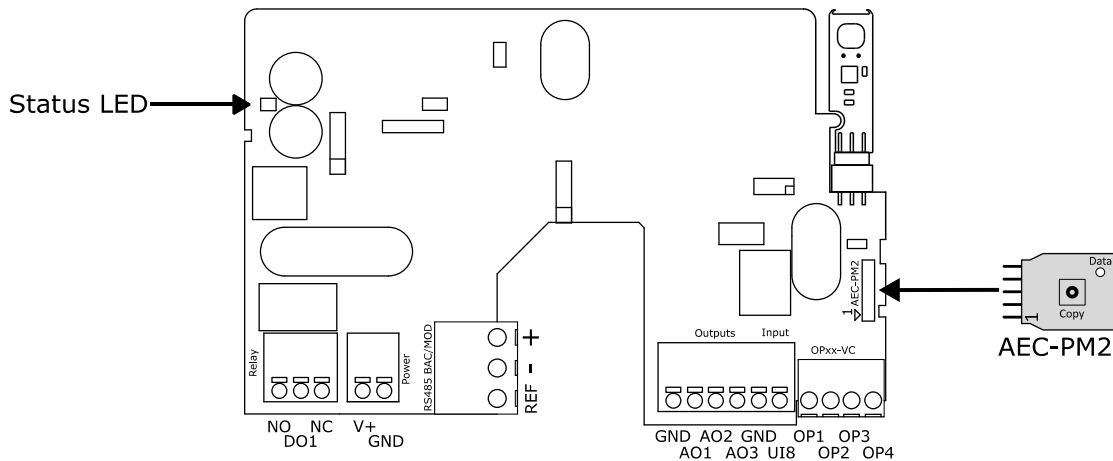
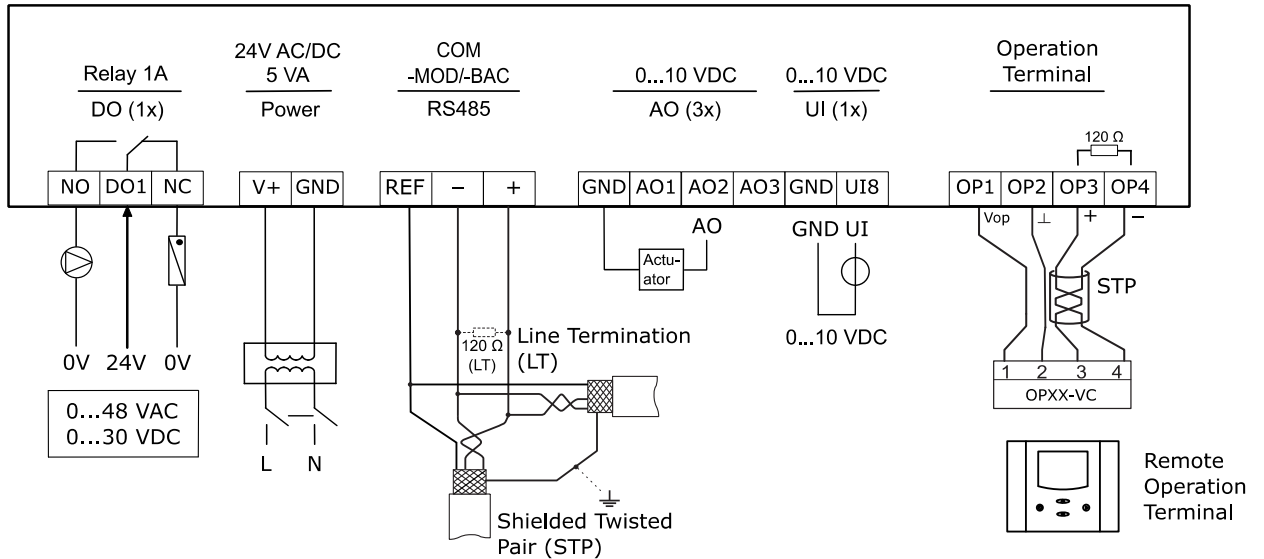

- GND** Power supply: 0V, -24VDC; common for power supply, analog in- and outputs
- V+** Power supply: 24VAC, +24VDC
- DO1** Binary outputs: Potential free low voltage relays contacts (see technical specification)
- AO** Analog output: 0...10 VDC
- UI8** Analog input: 0...10 VDC

Note on how to use UI8 as DI (digital input)



- Connect OP1 to Door contact to UI8
- Configure UI8 as 0-10 V input:
 - > 0V = 0% = contact open
 - > 10V = 100% = contact closed



Important

For the SRD2-OPIR type the following preset X2 input is assigned:

- UI7 = PIR sensor (passive infrared) for motion detection

Wiring of communication (RS485)

Wire type

An EIA-485 network shall use shielded, twisted-pair cable for data signaling with characteristic impedance between 100 and 130 ohms. Distributed capacitance between conductors shall be less than 100 pF per meter (30 pF per foot). Distributed capacitance between conductors and shield shall be less than 200 pF per meter (60 pF per foot). Foil or braided shields are acceptable.

Maximum length

The maximum recommended length per segment is 1200 meters (4000 feet) with AWG 18 (0.82 mm² conductor area) cable.

LED-indicators

SRD2 LED

A status LED is located on the SRD2 board in the controller housing. During normal operation, the LED flashes once every 5 seconds. If there is an alarm or fault condition, it will flash every second.



The function of the system LED is explained in the X2 Engineering Manual, document no. 70-00-0737.

Modbus LED (-MOD type)

The Modbus interface features a green LED and a red LED for indication of traffic on the RS-485 bus. The green LED is lit when an incoming packet is received, and the red LED is lit when an outgoing packet is transmitted to the bus. At power-up, both LED blink twice simultaneously as a sign of the boot process being completed. A constantly lit LED serves as an indication of a fault condition in the reception or sending process.

BACnet LED (-BAC type)

The BACnet interface features a green LED and a red LED for indication of traffic on the RS-485 bus. The green LED is lit when an incoming packet is received, and the red LED is lit when an outgoing packet is transmitted to the bus. At powerup, both LED blink twice simultaneously as a sign of the boot process being completed. A constantly lit LED serves as an indication of a fault condition in the reception or sending process.

Signal sound

SRD2 Buzzer

The SRD2's buzzer can be activated in the event of an alarm.



The function of the signal sound is explained in the X2 Engineering Manual, document no. 70-00-0737.

Dimensions, mm (inch)

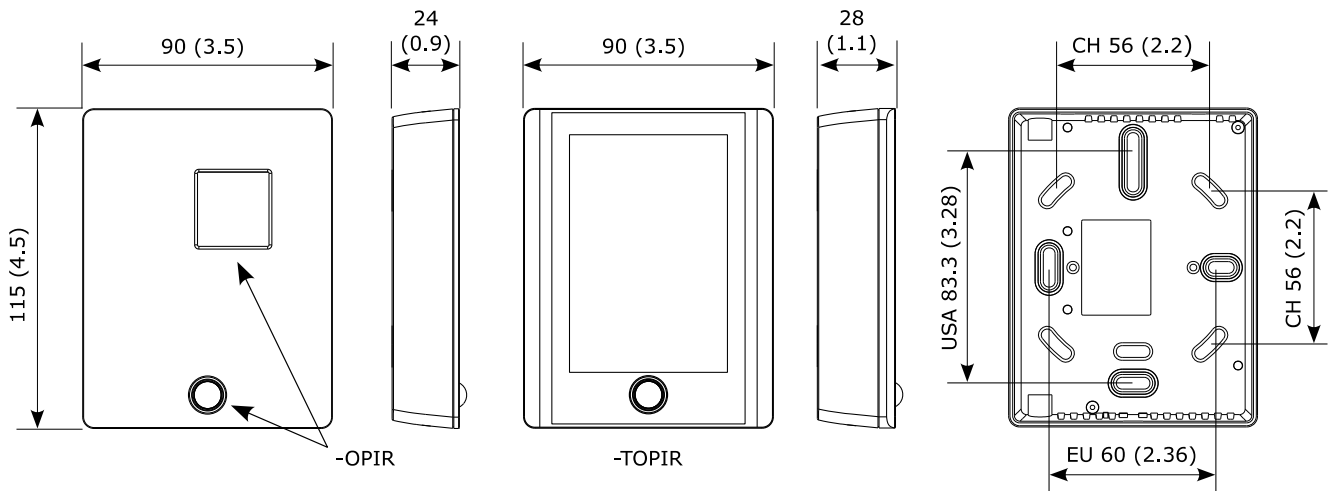

Sensors

Temperature & Humidity from RH sensor in -TH type

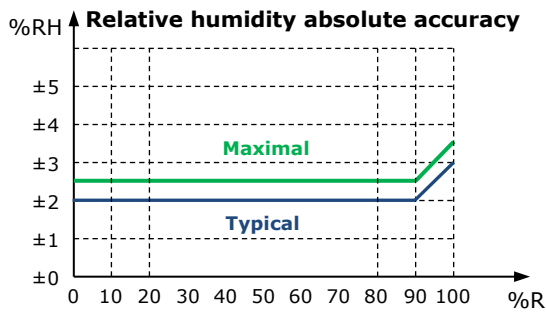

Figure 1: Typical and maximal RH accuracy at 25°C (77°F)

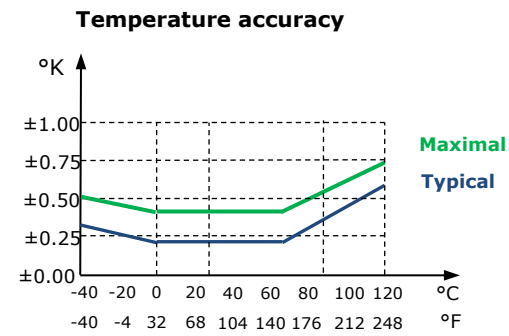

Figure 2: Typical and maximal temperature accuracy

CO2 sensor in -C type

The CO2 concentration is measured by NDIR photoacoustic sensor technology with automatic background calibration algorithm (ASC). The measurement technology used guarantees high reliability and long-term stability. The microprocessor measures the CO2 concentration once per second and calculates the signal value from a number of measured values.

Automatic CO2 background calibration (ASC)

Background Calibration (ASC) is turned on by default and constantly monitors the measured CO2 concentrations. The calibration function expects the CO2 concentration to periodically drop to fresh air levels of 400 ppm. Over a period of several days, the controller attempts to gradually reach this value by recalibrating a maximum of 30ppm per day.



To achieve the specified accuracy, it is necessary for the sensor to run continuously without power interruption for at least 3 weeks.

For special applications such as greenhouses, animal farms, etc., ASC calibration should be disabled and the sensor calibrated manually. The automatic calibration ASC can be deactivated via the external operating terminal OPA-S. The sensor can be calibrated by the customer and does not have to be sent in for calibration.

CO2 Calibration

The CO2 sensor unit is maintenance free in normal environments thanks to the built-in self-correcting ASC (Automatic-Self-Calibration) algorithm. This algorithm constantly remembers the sensor's lowest reading over a 7-day interval and slowly corrects any long-term deviation detected compared to the expected fresh air value of 400 ppm CO2. However, rough handling and transportation may result in a decrease in sensor measurement accuracy. Over time, the ASC function will return the readings to the correct values. However, the preset correction rate is limited to approximately 30 ppm/week.

Manual calibration may be applied in the event that one cannot wait for the ABC algorithm to cure any calibration offset or if ABC is disabled.

To calibrate the sensor, it is required to access the parameter setting of the device. The method to do this is described in the reference manual below.

There are two calibration options. They can be activated using input configuration parameter 03u9
 03u9 = 2 which requires that the sensor is exposed to fresh air (400 ppm CO2)
 03u9 = 1 which requires the sensor measuring cell to be completely evacuated from CO2 e.g. by exposing it to Nitrogen or Soda Lime CO2 scrubbed air.

Calibration procedure:

1. Before changing 03u9, expose the sensor element to either fresh air or nitrogen and make sure that the sensor environment is steady and calm.
2. Set 03u9 = 1 or 2 for 0 ppm or 400 ppm calibration.
3. Press right and up buttons to change to 0x u8 to store the calibration setting.
4. Set 03u9 = 3 to start the calibration stored.
5. Return to 0x u8 and wait for 5 seconds.

Check calibration status: If calibration succeeded it is 0x u9 = 0. If calibration failed it is 0x u9 = 7.



For more information on manual calibration, refer to the X2 Engineering Manual section "Manual calibration of CO2 sensor", document no. 70-00-0737.

VOC (Air Quality Sensor) in –Q type

Reliable evaluation of indoor air quality:

The sensing element used is a MOS (metal oxide semiconductor) based gas sensor component. It was specifically designed for a broad detection of reducing gases such as VOCs (volatile organic compounds) and CO (carbon monoxide) associated with bad air quality. The sensor has to run at least 24h for reliable VOC values. It has the following features:

- Sensing range: 0 – 100% AQI (air quality index)
- High sensitivity and fast response
- Module with automatic baseline correction



Note

The VOC sensor is recommended as an actuator for multi-stage ventilation systems. The VOC values can be classified into an air quality index.

Air Quality Index (AQI) values

The value 20 refers to the typical indoor gas composition over the past 24 h. While values between 20 and 100 indicate a deterioration, values between 0 and 20 inform about improvement of the air quality.



Dust particle sensor in –D type

The dust particle sensor uses the principle of laser light scattering. It accurately measures and calculates the number of particles present within a unit volume in the air, and reports the particle mass concentration in $\mu\text{g}/\text{m}^3$.

The detection size of the dust sensor can be configured.

Sensor configuration	Dust particle size	SRD2 default
PM1.0	1.0 μm	
PM2.5	2.5 μm	X
PM10	10 μm	



For more information on dust sensor configuration, refer to the X2 Engineering Manual section "Sensor inputs", document no. 70-00-0737.

Temperature influence on accuracy

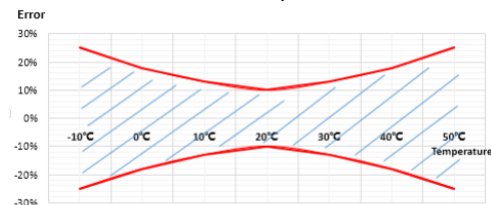

Formaldehyde Sensor (F)

The used formaldehyde sensor is a fuel cell electrochemical sensor. The principle of the sensor is as follows: formaldehyde and oxygen undergo corresponding redox reactions at the working and counter electrodes, releasing the charge to form an electric current. This current is then measured, calibrated and temperature compensated. As this is an electrochemical sensor, its electrodes have a limited lifespan. In order to guarantee accurate measurement, it must therefore be replaced after 2- 3 years.

Passive infrared (PIR) sensor in –IR type

The 120° detection range of the PIR sensor of a wall mounted SRD2 is shown below.

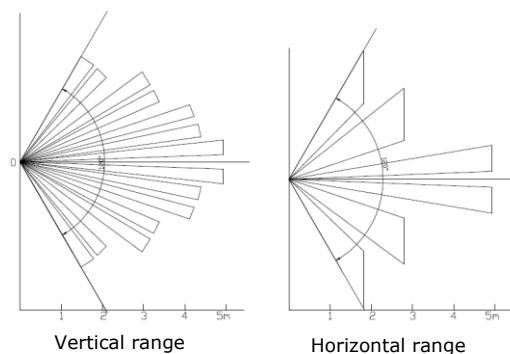

Pre-Configured Variants

Vector Controls offers a range of pre-configured SRD2 products for a wide variety of functions, including:

- Dew Point Sensor Function
- Enthalpy Sensor Function
- ...

The features of the preconfigured SRD2 products are explained in the following sections.

SRD2 Dew Point Pre-Configuration (-W8 / -W28 option)

When ordering the SRD2 with the -W8 or -W28 option, the SRD2 is preconfigured as a Dew Point Sensor. With the dew point configuration, the SRD2 provides the following features:

- Monitors the dew point or humidity level and activates a relay when the dew point or relative humidity exceeds the set limit.
- Stops condensation before it starts
- Analog output of dew point temperature, measured temperature and absolute humidity
- Optional display (-OPIR type)

For ordering information, refer to the chapter "Ordering of pre-configured SRD2 models" on page 3.

Dew Point Function Settings

SRD2 Settings	-W8 (ISO Units)	-W28 (Imperial Units)
Output signal configuration		
AO1 Analog Output - Calculated dew point temperature	0...10 VDC = -40...60°C	0...10 VDC = -40...140°F
AO2 Analog Output - Current measured temperature	0...10 VCD = -40...60 °C	0...10 VCD = -40...140 °F
AO3 Analog Output - Current measured absolute humidity	0...10 VCD = 0...100 g/m ³	0...10 VCD = 0...44 gr/f ³
DO1 Digital Output (Changeover relay) - Dew point limit DRY - Dew point limit WET	NO to DO1 connected NC to DO1 connected	
Dew Point setting (default)		
Dew point limit WET - if current temperature is < dew point limit	2 °C	4 °F
Dew point limit DRY - if current temperature is > dew point limit	3°C	6 °F
Built-in display (-OPIR only)		
Standard Display - Dew point temperature - Current temperature - Current absolute humidity - Current relative humidity	°C °C g/m ³ % RH	°F °F gr/f ³ % RH

Wiring and Connection for Dew Point Pre-Configuration

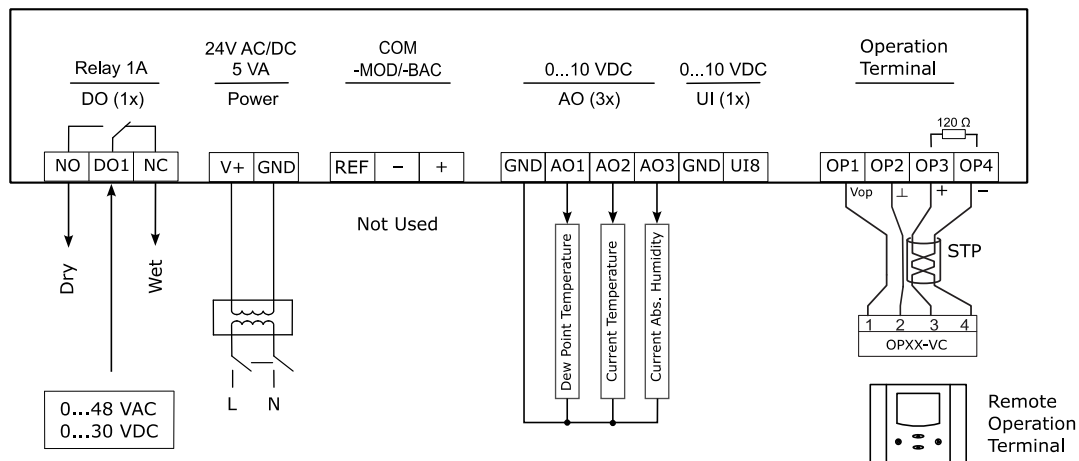

Adjusting the Dew Point Limits

To set the dew point limit values, refer to the parameter table below.

Configuration Parameters

The device can be fine-tuned by adjusting the software parameters. The parameters are set using the external operation terminal OPT1 / OPA2 or the free configuration tool EasySet.

Parameter	Description	Range	Default
1D 14	Dry: Reset current – dew point temperature	-40...215 °C/F	3°C
1D 15	Wet: Switching difference current - dew point temperature	-40...215 °C/F	2°C

SRD2 Enthalpy Pre-Configuration (-W9 / -W29 option)

When ordering the SRD2 with the -W9 or -W29 option, the SRD2 is preconfigured as an Enthalpy Sensor. With the enthalpy configuration, the SRD2 provides the following features:

- The SRD2 calculates the Enthalpy (internal energy) of the current air
- Analog output of the Enthalpy value and relative humidity
- Optional display (-OPIR type)

For ordering information, refer to the chapter "Ordering of pre-configured SRD2 models" on page 3.

Enthalpy Function Settings

SRD2 Settings	-W9 (ISO Units)	-W29 (Imperial Units)
Output signal configuration		
AO1 Analog Output - Calculated Enthalpy of the humid air	0...10 VDC = 0...500 kJ/kg	0...10 VDC = 0...200 BTU/lb
AO2 Analog Output - Current measured temperature	0...10 VCD = -40...60 °C	0...10 VCD = -40...140 °F
AO3 Analog Output - Current measured relative humidity	0...10 VCD = 0...100% RH	0...10 VCD = 0...100% RH
DO1 Digital Output (Changeover relay)	Not active	
Built-in display (-OPIR only)		
Standard Display - Enthalpy of the air - Current temperature - Current relative humidity	kJ/kg °C % RH	BTU/lb °F % RH

Wiring and Connection for Enthalpy Pre-Configuration

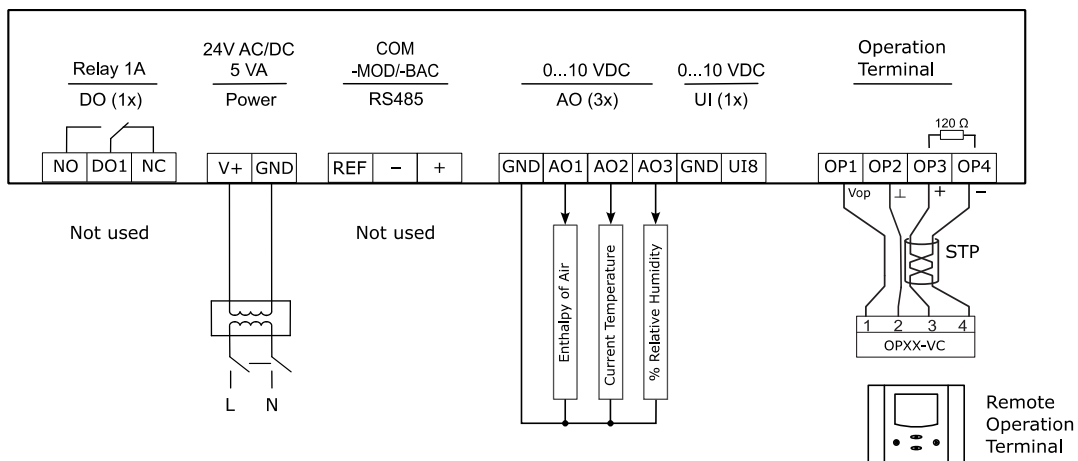

Operation and Configuration

Documentation

This controller uses the latest generation X2 operating system. Detailed operation instructions for all devices equipped with this operating system can be found on our website www.vectorcontrols.com.

Also available are programming instructions for technicians and an application database.



More information on the X2 operating system can be found on our website www.vectorcontrols.com under "X2 Controls".

Configuration

Configuring with EasySet (free PC application)

We recommend to use the PC and the EasySet tool to easily configure the SRD2 to your needs. Connect the PC with the EasySet tool via the AEC-USB converter or use the PC's Wi-Fi communication to connect to the SRD2 (SRD2-WIM /-WIB types only). Refer to the SRD2 installation sheet for connection details and the X2 Engineering Manual for configuration details.



The device can be fully configured and commissioned using the EasySet program. EasySet may be downloaded free of charge from our website www.vectorcontrols.com.

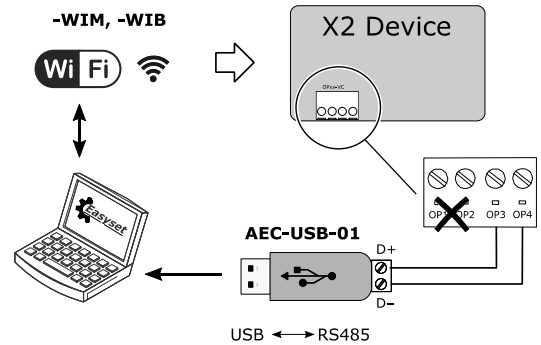

Configuring with operation terminal

Alternatively, the SRD2 can also be configured via an external operation terminal (OPT1-xx, OPA2-xx, OPF2-xx) to your needs. Connect the terminal to the OPxx-VC connectors on the SRD2. Refer to the SRD2 installation sheet for connection details and the X2 Engineering Manual for configuration details.



For more information on configuration, refer to the X2 Engineering Manual, document no. 70-00-0737.

Copy configuration to other SRD2 devices

Complete parameter sets may be copied using the accessory AEC-PM2 or exchanged with a PC using the EasySet tool and an RS485-USB converter or via Wi-Fi communication.

Copy configuration with the AEC-PM2 (plug-in memory)

To load the configuration into the AEC-PM2, we recommend using the EasySet "Copy Memory" function. Alternatively, an external operation terminal can be used to instruct the SRD2 to load the configuration into the AEC-PM2 (see X2 Engineering Manual and SRD2 Installation Sheet).

To copy the configuration to another SRD2, simply connect the AEC-PM2 plug-in memory to the SRD2 and press the copy button (see the SRD2 installation sheet for connection details).

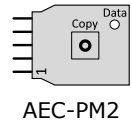

Copy configuration with EasySet (free PC application)

To copy the configuration to another SRD2 device, connect the PC with the EasySet tool via the AEC-USB converter or use the PC's Wi-Fi communication to connect to the SRD2 (for SRD2-WIM /-WIB types only). Refer to the SRD2 installation sheet for connection details.



For more information on configuration, refer to the X2 Engineering Manual, document no. 70-00-0737.

Documentation overview

Document Type	Document No.	Description
SRD2 Data Sheet	70-00-0979	Product data sheet (this document)
SRD2 Install Sheet	70-00-0978	Mounting and installation manual
X2 Operations Manual touch button display	70-00-0994	Operations instructions of X2 system with touch button and display
X2 Web Interface operation manual	70-00-0952	Operations instructions of X2 Web interface
X2 Engineering Manual	70-00-0737	Guidelines for configuring the X2 system
X2 Modbus Communication Module (-MOD type)	70-00-0290	Setup and configuration manual Modbus (no Modbus TCP)
X2 Modbus Communication Module (-WIM type)	70-00-0925	Setup and configuration manual Modbus TCP
X2 BACnet Communication Module (-BAC type)	70-00-0218	Setup and configuration manual BACnet (no BACnet/IP)
X2 BACnet/IP Communication Module (-WIB type)	70-00-0899	Setup and configuration manual BACnet/IP
X2 Wi-Fi / Ethernet Communication Manual (-WIM, -WIB type)	70-00-0900	Setup and configuration manual TCP/IP

Note: The above list is not complete. The documents on the website are relevant.

BACnet (PICS)

Protocol Implementation Conformance Statement for BACnet MS/TP and BACnet IP network

 The following is only valid for products with the **-BAC and -WIB** option.

Vendor Name: Vector Controls
 Product Name: SRD2 Controls series
 SRD2 product description: The SRD2 communicating BACnet controllers are designed as universal controls equipment suitable for a large number of applications. They may be used in zoning and other applications which are monitored by a BACnet MS/TP network.

▲ Supported BACnet Interoperability Blocks (BIBB)

The BACnet interface conforms to the B-ASC device profile (BACnet Application Specific Controller). The following BACnet Interoperability Building Blocks (BIBB) is supported.

BIBB	Type	Name
DS-RP-B	Data sharing	Read property - B
DS-RPM-B	Data sharing	Read property multiple - B
DS-WP-B	Data sharing	Write property - B
DS-COV-B *1)	Data sharing	Change of value - B
DM-DCC-B	Device management	Device communication Control - B
DM-DDB-B	Device management	Dynamic device binding - B
DM-DOB-B	Device management	Dynamic object binding - B
DM-TS-B	Device management	Time synchronisation - B
DM-UTC-B	Device management	UTC Time synchronisation - B
DM-RD-B	Device management	Reinitialize device - B

*1) With -BAC, a maximum of 5 COV objects can be activated at the same time. This limitation does not apply to -WIB.

▲ Supported standard BACnet application services

- ReadProperty
- ReadPropertyMultiple
- WriteProperty
- DeviceCommunication (password protected)
- I-Am
- I-Have
- TimeSynchronisation
- UTCTimeSynchronisation
- ReinitializeDevice ("cold" or "warm") (password protected)

▲ Supported standard Object types

- Device
- Analog input
- Analog value
- Binary value
- Multi-state Value

X2 Functional Scope

The controller has the following X2 functions and elements:

Group	Modules	QTY	Description
UP			User and display parameters
UI	01U to 06U	6	Sensor inputs for temperature, humidity, CO2, VOC and dust particle sensor (PMxx)
	07U	1	PIR sensor as motion detector (only SRD2-OPIR type)
	08U	1	Active input 0...10 VDC
	09U to 12U	4	Virtual inputs for operation terminals, bus modules or special functions
AL	1AL to 8AL	8	Alarm conditions
LP	1L to 4L	4	Control loops
Ao	1A to 3A	3	Analog outputs for 0...10 VDC
FAN	1F	1	Fan or lead lag modules, 1 to 3 fan speeds, up to 3 switching lead-lag stages each
do	1d	1	Binary output with a normally open and a normally closed (SPDT) relays contact
FU	1FU	1	Remote Enable: Activation of the controller based on signal and alarm conditions
	2FU	1	Change Operation Mode: Switching occupied and unoccupied with control signals
	3FU	1	Heat/Cool Change: Switching heating and cooling based on a control signal
	4FU	1	Setpoint Compensation: Summer/winter compensation of setpoint
	5FU	1	Economizer (free heating or cooling due to the condition of outside and room air)
Co			Communication (if a communication module is available)
COPY			Copying complete parameter sets between run, default and external memory with up to 4 memory locations (AEC-PM2)

Smart Sensors and Controls Made Easy!

Quality - Innovation – Partnership

Vector Controls GmbH
Switzerland

info@vectorcontrols.com
www.vectorcontrols.com

