

## MZ3-FU-V11 Controller/positioner for comfort ventilation

### Function

- Positioner and controller for comfort ventilation with touch panel
- Manual operation with up to 4 Levels, OFF, minimum air, 1st Level, 2nd Level, maximum air
- AUTO level mode: The controller activates the ventilation level based on controls curve. The controls curve may be adjusted
- AUTO Continuous mode: The controller adjusts the ventilation level gradually between adjustable minimum and maximum according to sensor value
- One 0...10 VDC input for connection of a CO2 or air quality sensor
- One 0...10 VDC controls output to control the ventilation system
- Automatic reset of the maximum air level (standard: level 0 after 120 min.)
- Password protected controls settings
- Copy of settings with accessory (AEC-PM2)



### Applications

This device is designed to control ventilation systems for comfort applications. For example, for well insulated residential areas which are required to be ventilated or for controlling dampers, valve drives, blinds or windows, etc.

### General description

The MZ3-FU-V11 is a microprocessor-controlled precision positioner / proportional controller with touch panel. Through user and engineering parameters the positioner may be configured to work for most of the standard ventilation applications. The device is pre-configured according to this documentation. Settings such as switching levels of the control curve and ventilation strengths for each Level may be adjusted. The configuration may be performed using the programming device called OPA-S. This device may be used as well to visualize measuring values. Configuration can as well be updated using a remote memory device called AEC-PM2.

### Safety



#### **DANGER! Safety note**

This device serves as an actuator or proportional controller for ventilation systems. Where a control failure would result in personal injury and/or property damage, it is the responsibility of the customer, designer and installer to install additional equipment and devices that will prevent a control failure or warn if limits are exceeded.

The device contains electronic components and must not be disposed of with household waste.

### Types and ordering

Product name	Product No.	Description	Features
MZ3-FU-V11-B-T4-W	40-100230	- Blue LED - White frame - Lettering: Minimum, Normal, Maximum, Party	Compact positioner / controller in a white frame, with one 0-10 VDC input and output. Operation as 4-Level switch with touch panel and AUTO function.

#### **Accessories**

OPA-S	40-500006	Programming and display device	LCD display for surface mounting or handheld operation.
AEC-PM2	40-500130	Memory-Device. Used for copying settings	Stores settings of MZ3

## Interface to the ventilation system

The positioner works with all systems that are designed for a 0...10 VDC or 2...10 VDC input signal.

## Selection of transmitters

The position transmitter works for all sensors/probes which can generate an output signal of 0...10 or 2...10 VDC. The corresponding measuring range must be observed.

Example of suitable Vector Controls CO2 sensors:

- SDC-C1-16-1
- SDC2-16-C-200.101U-1

Example of suitable Vector Controls air quality (VOC) sensors:

- SDC-Q1-16-1
- SDC2-16-THQ-210.102U-1



Further details on a variety of suitable sensors can be found on our website ([www.vectorcontrols.com](http://www.vectorcontrols.com)).

## Technical Data

<b>Power supply</b>	Operating voltage	24 V AC/DC $\pm$ 10%, 50/60 Hz, Class 2 48 VA max.
	Power consumption	Max. 1 VA
	Electrical connection	Terminal connectors, wire 0,34-2,5 mm <sup>2</sup> (AWG 22...13)
<b>Signal input</b>	Analog input	0...10 VDC
	Impedance	98 k $\Omega$
<b>Signal output</b>	Analog output	DC 0...10 V
	Output signal	2 mA or 5 k $\Omega$
	Maximum load	
<b>Environment</b>	Operation	To IEC 721-3-3
	Climatic conditions	class 3K5
	Temperature	0...50 °C (32...122 °F)
	Humidity	< 95% RH non-condensing
	Transport & storage	To IEC 721-3-2 and IEC 721-3-1
	Climatic conditions	class 3K3 and class 1K3
Temperature	-25...70 °C (-13...158 °F)	
Humidity	< 95% RH non-condensing	
Mechanical conditions	class 2MT2	
<b>Standards</b>	Degree of protection	Wall mounted: IP40 acc. EN 60529
		Not installed: IP00 acc. EN 60529
	Safety class	III (IEC 60536)
<b>General</b>	Housing material:	Flame retardant PC+ABS plastic (UL94 class V-0)
	Dimensions (H x W x D) including packaging	145 x 105 x 70 mm (5,7" x 4,1" x 2,8")
	Weight (incl. packaging)	155 g (5.5 oz)

## Product testing and certification



Declaration of Conformity

Information on the conformity of our products can be found on our website [www.vectorcontrols.com](http://www.vectorcontrols.com) on the corresponding product page under "Downloads".

**Connection diagram**

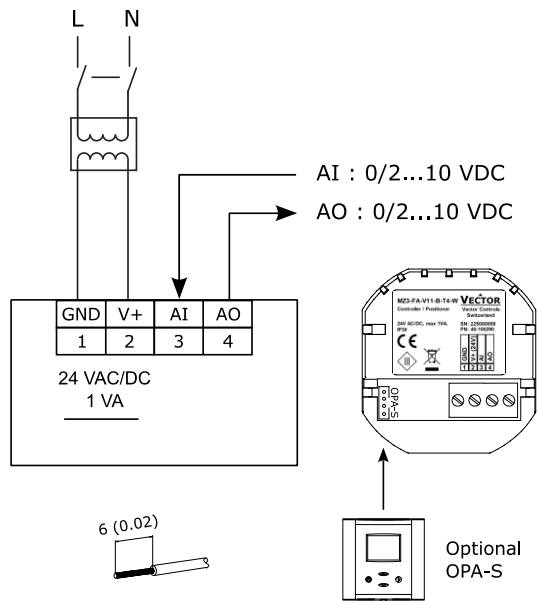

**Description:**

- 1 GND** Power supply: 0 V, -24 VDC, internally connected to signal common
- 2 V+** Power supply: 24 VAC, +24 VDC
- 3 AI** Analog input for sensor: 0/2...10 VDC
- 4 AO** Analog output ventilation: 0/2...10 VDC

**Mounting instruction**



For more information on mounting, refer to MZ3-FU-V11 Installation Manual No. 70-000839 ([www.vectorcontrols.com](http://www.vectorcontrols.com)).

**View of rear part, without front panel**

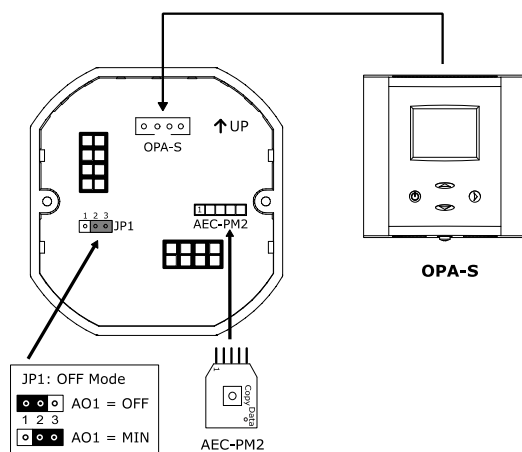

**NOTE:** For parameter programming, the OPA-S programming and display device must be plugged into the connector under the front panel or on the rear of the MZ3. If an OPA-S programming and display unit is permanently connected to the MZ3, parameter programming is performed with this unit.

**Dimensions mm (in)**

The MZ3-FU-V11 is so designed that it can be incorporated into a commercially available flush box.

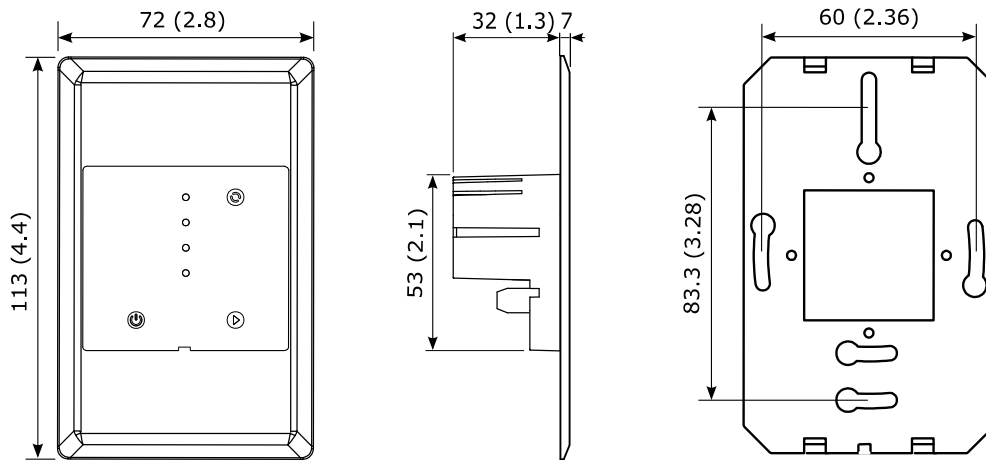

**Display and Operation**

**ON/OFF operation**

The device is activated by pressing the ON/OFF button. Depending on the position of JP1, the minimum air volume remains active even during OFF mode. In OFF mode, the operating mode symbol lights up with reduced intensity.

**Manual operation**

The following operation modes will be activated through repeated pressing of the level button:

- Level 0 = Minimum volume [Minimum]
- Level 1 = Normal volume [Normal]
- Level 2 = High volume [Maximum]
- Level 3 = Maximal volume [Party]
- Auto operation (automatic level selection)

The active level is activated after 3 seconds. This prevents unnecessary switching when setting the device. The level-indication and buttons light up in green or blue depending on the type of device.

The device is equipped with proximity detection. When approaching a distance of approx. 10 cm, the luminosity of the LED increases. After 30 seconds without interaction, the LEDs dim down again and thus save energy.

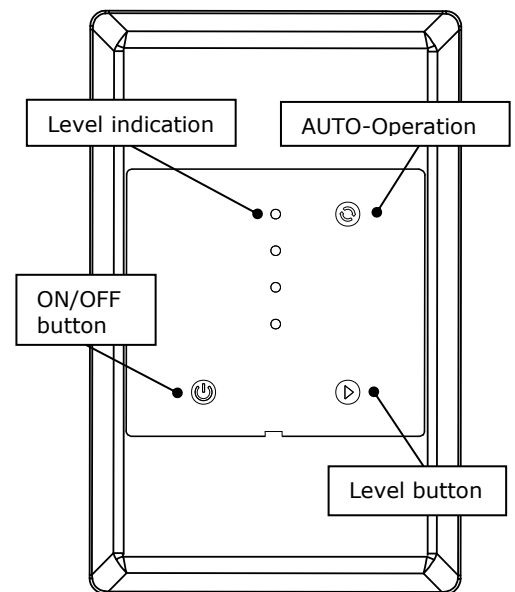

## Operating Modes

### Manual operation

In manual mode, the ventilation level is defined by means of the level button, see section „Display and Operation“ on page 4.

### Automatic operation

The automatic operation of the device is enabled once a sensor signal is detected at the input AI.

Automatic operation must be activated with the level button or through the automatic reset function defined with **IP08**, see section “Display and Operation” on page 4 and “Input configuration (AI)” on page 6.

The IP08 parameter defines the amount of time after which the unit will return to automatic mode if it has been manually overridden or switched off. If the unit has been switched off, it will reactivate itself once the reset time has elapsed. Setting the reset time to 0 deactivates automatic reset.

### Level mode (IP00=ON)

During AUTO operation, the levels are switched by a control signal. The switching levels are defined under IP04 – IP06. The hysteresis defined with IP07 prevents rapid switching of levels in auto mode.

Function: A level activates once the input signal exceeds the activation limit (IP04-IP06). It deactivates once the input signal drops below the activation limit minus the hysteresis. For example, with a hysteresis of 10% and an activation limit of 40%, the level activates with a 40% input signal and switches down to the next lower level with a 30% input signal.

Automatic switching for certain levels may be disabled by setting an activation limit of 0. The sensor signal will then not be able to activate this particular level. This may be useful for the highest level (boost mode) by setting IP06 = 0.

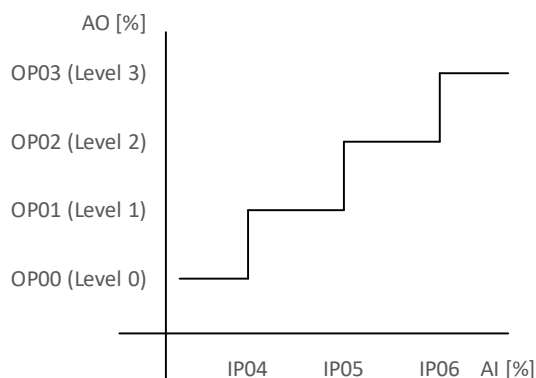

Figure 1: Function level mode

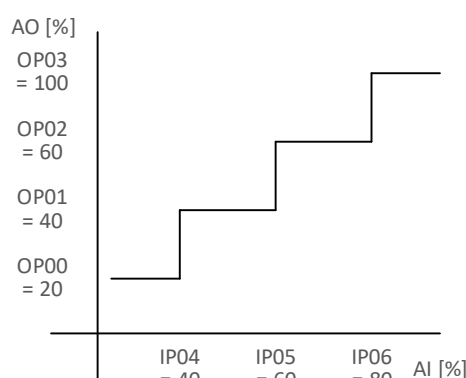

Figure 2: Example level mode

### Continuous mode (IP00=OFF)

During AUTO operation, the ventilation is controlled gradually by the sensor signal. Instead of level steps, the output voltage is adjusted continuously. The sensor minimum and sensor maximum of the linear range can be set with IP04 and IP06. The output voltage then behaves linearly between OP00 and OP03.

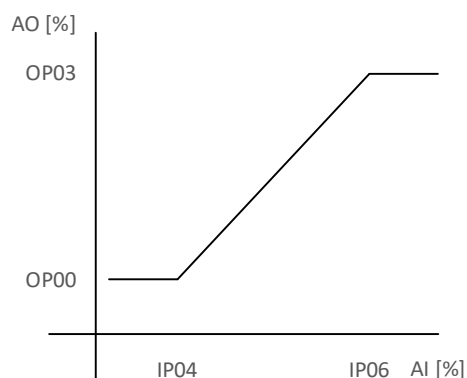

Figure 3: Function continuous mode

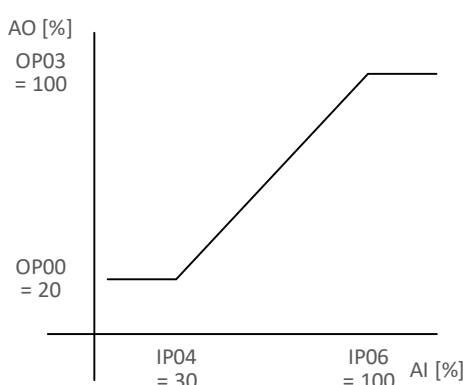

Figure 4: Example continuous mode



**NOTE:** If the MZ3 is used in conjunction with a Vector Controls VOC or CO2 sensor, the following settings are recommended:

- IP04 = 20% (20% AQI / 400 ppm)
- IP06 = 100% (100% AQI / 2000 ppm)
- OP00 = 0% (0 V)
- OP03 = 100% (10 V)

## Configuration

### Configuration of the output signal and jumper

- If JP1 is in position 1-2, the output signal is 0 VDC in OFF mode
- If JP1 is in position 2-3, the output signal remains at level 0 (minimum volume) in OFF mode according to OP00

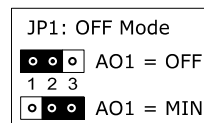

The jumper position can be seen in section "View of rear part, without front panel" page 3.

### Input configuration (AI)

Parameter	Description	Range	Default
IP00	Auto operation mode - ON: Level mode: Output jumps to the defined level depending on the input values in: OP00, OP01, OP02 or OP03 - OFF: Continuous mode: Output behaves linear between OP00 and OP03 in Auto mode.	ON, OFF	ON
IP01	Samples taken for averaging input signal	1...255	3
IP02	Offset of input signal (Uout = Uset + Offset)	-10...+10	0
IP03	Input signal type: - OFF: 0-10V - ON: 2-10V	ON, OFF	OFF
IP04	- Level mode: Sensor switching limit of level 1. - Continuous mode: Sensor start value for continuous control for the minimum output voltage according to OP00	0...100%	40%
IP05	- Level mode: Sensor switching limit of level 2. Note: If this level is set to 0, it is deactivated for level mode. <sup>1)</sup> - Continuous mode: Not used. <sup>2)</sup>	0...100%	60%
IP06	- Level mode: Sensor switching limit of level 3. Note: If this level is set to 0, it is deactivated for level mode. <sup>1)</sup> - Continuous mode: Sensor end value for continuous control for the maximum output voltage according to OP03	0...100%	80%
IP07	Hysteresis of level operation	0...100%	10%
IP08	Reset time manual to auto operation. This function will reactivate the device if it has been switched off. 0: Never reset	0...255 min	0 min

<sup>1)</sup> The smallest deactivated level determines up to which level the automatic level mode can regulate.

<sup>2)</sup> If IP06 = 0, IP05 is the sensor end value for the maximum output voltage according to OP02.

### Output configuration (AO)

Parameter	Description	Range	Default
OP00	Output level 0: 0...100 % = 0...10.0 VDC	0...100%	20% = 2 V
OP01	Output level 1: 0...100 % = 0...10.0 VDC Note: setting a level to 0 disables it	0...100%	40% = 4 V
OP02	Output level 2: 0...100 % = 0...10.0 VDC Note: setting a level to 0 disables it	0...100%	60% = 6 V
OP03	Output level 3: 0...100 % = 0...10.0 VDC Note: setting a level to 0 disables it	0...100%	100% = 10 V
OP04	Automatic reset time of the highest level to the level defined in OP05. The reset is deactivated with setting = 0	0...255 min	120 min
OP05	Level after automatic reset. This level will be activated once the reset time defined in OP04 has expired.	0...2	0
OP06	- 0: Parameter copy successful; No action - 1: Start parameter copy to AEC-PM2 - 7: Copy fail (no AEC-PM2 or communication error)	0...1 7: display only	0

**Setting the parameters**

The MZ3 is designed to work for most comfort ventilation applications. It is however possible to fine tune it to fit perfect into the application at hand. The parameters can be changed during operation through an operation unit called OPA-S. The operating unit OPA-S must be connected for the adjustment of the parameters with the MZ3.

Carefully lift the front panel of the MZ3 and pull it away to the front. Plug the connecting cable of the OPA-S operating unit into the rear part of the MZ3.

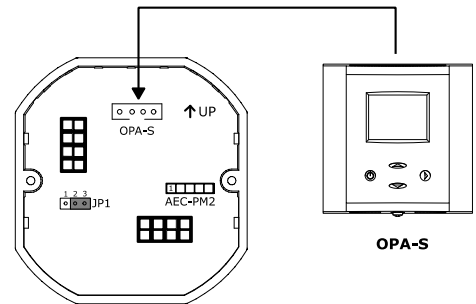

**Important**

The MZ3 does not accept the new settings until the OPA-S parameter menu is exited. The connection must not be disconnected earlier than five seconds after the last keystroke!

**Copy parameters**

It is now possible to copy settings to an accessory (AEC-PM2) and to copy them back to other MZ3. For this, remove the front panel of the MZ3, insert AEC-PM2 in the designated plug.

**Copy parameters from MZ3 to AEC-PM2**

Connect OPA-S and copy parameters from MZ3 to AEC-PM2 by setting OP06 to 1. The "Data" LED of the AEC-PM2 lights up for 5 seconds after successful parameter copying and OP06 is set to 0. If parameter copying has failed, the LED flashes for 5 seconds and OP06 is set to 7.

**Copy parameters from AEC-PM2 to MZ3**

Copy the parameters from AEC-PM2 to MZ3 simply by pressing the "Copy" button on the AEC-PM2. The "Data" LED on the AEC-PM2 will light for 5 seconds after the parameters have been successfully copied. If the parameter copy failed, the LED will blink for 5 seconds.

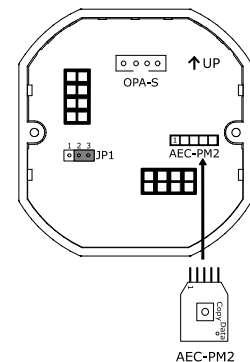

## **Smart Sensors and Controls Made Easy!**

### **Quality - Innovation – Partnership**

Vector Controls GmbH  
Switzerland

[info@vectorcontrols.com](mailto:info@vectorcontrols.com)  
[www.vectorcontrols.com](http://www.vectorcontrols.com)

