

X2-Engineering Manual

This manual serves as engineering guideline for all Vector Controls products running the X2-operating system. It explains how to configure and fine tune a controller or sensor. All X2 devices work in the same way. Availability features and number of functions are product dependent. All available features are listed on the datasheet of each product. Each function is explained in detail. Some application examples give a direct how-to help to technicians working with X2 products.

X2-operating system

The X2-Operating system consists of a standardized method to operate and configure a range of controllers and sensors. The system is built on pre-programmed control and function blocks which can be configured using a parameterization routine. All X2-type products use the same philosophy and can be configured using the same tools and methods. All X2-type products can be configured using the standard operation terminals, the PC based tool EasySet™ from Vector Controls or remotely through bus communication where available. Data sets can be copied and stored using a memory plug-in called AEC-PM1 or AEC-PM2.

Table of contents

1	Introduction	3
2	Parameter settings	4
3	Backup and restore of configuration	6
4	User and display settings	8
5	Inputs	12
6	Alarms and Interlocks	24
7	Control loop configuration	30
8	Analog outputs	35
9	Digital outputs	40
10	Fan configuration	41
11	Lead-lag configuration	44
12	Floating output (d00 = ON)	46
13	Digital output (d00 = OFF)	50
14	Auxiliary functions	55
15	Time Scheduling	63
16	Appendix	65

1 Introduction

1.1 X2-product range

X2 devices are created to fit different applications and mounting locations. Here a brief summary:

TCX2 and TCI2 are cabinet mounted devices. Typical applications are AHU, fan coil, pumps, ventilation, chiller control

SRD2 and TRI2 are wall mounted controllers. The TRI2 has temperature and humidity inputs and the SRD2 up to 6 different inputs such as temperature, humidity, CO₂, VOC, dust (PM1.0, PM2.5, PM10), PIR, differential pressure and formaldehyde.

SOC2, SDC2 and SCC2 are controllers and sensors for outdoor and duct mounting with temperature, humidity, CO₂ and VOC as sensing devices. The SCC2-P is a communicating differential pressure sensor.

The latest addition to the range is the VAV controller TVC2. It contains a differential pressure sensor plus a range of in and outputs.

All the available X2 devices are on our webpage. All technical specifications may be found in the datasheet of the respective product.

1.2 I/O-Module (TCX2-0xxxx)

The TCX2-00863 is an I/O-Module. It has no control function. It in and outputs can be controlled through communication. These devices do only make sense together with servers or cloud functions for monitoring or remote control.

An I/O-Module has no control function, no auxiliary functions and 4 alarm functions. Apart from this it has all the other configuration option as a standard X2 device.

Standard devices may be configured to I/O-mode as well by just reading their inputs and setting their outputs. Important is that the outputs are set to I/O-Mode. In this mode, the setting for the output is written to volatile memory only. With standard manual mode, the configuration is saved in non-volatile memory. That memory has maximum number of writes limitation of 100'000 cycles.

For I/O-modules that control devices, we recommend setting up a time out alarm by writing regularly to a virtual input. That virtual input is then monitored with an alarm. If the input runs into a timeout, the alarm will trigger and deactivate or activate the outputs based on their configuration.

1.3 Real time clock and processor-based time clock

Some X2 devices contain a real time clock. This real time clock is accurate to 2 seconds per day and contains a 48-hour rechargeable power backup. Thanks to this power backup, the time does not need to be re-entered if power is removed and returned within 48 hours.

The unit controllers for the TCX2 range contain a processor-based time clock. This clock is accurate to about 2 Minutes per day. It thus needs to be synchronized every 24 hours by a time server. It is only recommended to use time functions with this device if time is in fact re-synced once a day.

Only the controller with a time base will have time schedules enabled. A time base can be a real time clock or a processor-based time clock.

1.4 Understanding X2-product names

All X2 devices try to follow a logic in name. With this logic it is possible to determine type and number of in-, outputs, control loops and sensors involved.

The key for these series: **TCI2, TRI2, TCV2, SDC2, SOC, SCC2, SRD2**

Series	Probe	Sensors				Configuration								Options	Communication			Connection					
		Temperature	Humidity	CO2	VOC	Control Loop	Passive In	Analog In		Relay Out	TRIAC Out	Analog Out	Universal		Clock &	Operation Terminal	MODBUS	BACnet MS/TP	WI-FI	Cable blend	Conduit connector		
SDC2	- 16	T	H	C	Q	2	1	0	.	1	0	2	U	C	-	OP	-	MOD	BAC	WIFI	-	1	2

Following exceptions:

- only SDC2-devices have a probe
- TCI2-devices do not have Sensors

The key valid for **TCX2**-devices:

Series	Configuration						Options	Communication				
	Control Loop	Passive In	Analog In	Digital Out	Analog Out	Universal		Operation Terminal	MODBUS	BACnet MS/TP	WI-FI	
TCX2	- 4	0	8	6	3	U	-	OP	-	MOD	BAC	WIFI

2 Parameter settings

2.1 Setting parameters to configure the controller

X2 devices are programmable devices with the flexibility to fit a wide range of applications. Their functionality and operation is defined by parameters. They can be set using the standard operation terminal. There are two levels:

- 1. User/display parameters (default password 0009)**
- 2. Control parameters (default password 0241)**

Parameters are grouped according to modules:

Not all X2-products contain the same amount and type of function blocks. The product documentation contains a list of the available number and type of functions for the particular product.

Module	Description	Level	PW
UP	User and display parameters	User	009
LP	Control loops	Engineering	241
UI	Input configuration		
AL	Alarm configuration		
FU	Auxiliary functions		
AO	Analog output configuration		
FAN	Fan output configuration		
DO	Digital output configuration		
Co	Communication setup (refer to separate communication brochure)		
COPY	copy mode to copy full parameter sets between run, default and external memory with up to 4 saving locations		

2.2 Recommended set-up procedure:

- 1 Set jumpers on the back of the controller for inputs and outputs
- 2 Connect power supply and inputs
- 3 Make sure Celsius – Fahrenheit settings are correct (UP07)
- 4 Program input parameters
- 5 Program control parameters
- 6 Program output parameters
- 7 Program auxiliary functions and user settings
- 8 Test function of unit
- 9 Switch off power
- 10 Connect outputs
- 11 Reconnect power
- 12 Test control loop

2.3 How to change parameters directly on the device

Parameters may be accessed through on board or remote operating terminals.



Access to parameters may be inhibited by the supplier of the controller. In this case the below mentioned procedure will not work.

1. Press UP/DOWN buttons simultaneously for three seconds. The display will show firmware version and revision number. Press the OPTION button to start the login process.
2. CODE is shown in small display. Select 241 using the UP or DOWN button. This the default password. In case it does not work the installer may have changed the password or blocked access to the parameters completely. The parameters should only be changed by authorized personnel.
3. Press OPTION after selecting the correct password. The user/display parameters are displayed immediately.
4. Once logged in with the correct password, the available parameter groups are displayed (UI, AL, LP, AO, FAN, DO, CO etc.) – select with UP/DOWN the desired group, press the OPTION button. Then select the ID with UP/DOWN buttons: (e.g. 1U, 2U, 3U etc.), press the OPTION button again to display the parameter available for this ID.
5. Select the parameters with the UP/DOWN buttons. Change a parameter by pressing the OPTION button. Three arrows are displayed to indicate that the parameter may be modified. Use UP/DOWN buttons to adjust the value.
6. After you are done, press OPTION to save the new value and return to the selection level (arrows disappear when selection is saved). Pressing left hand POWER button without pressing OPTION will discard the value and return without saving.
7. Press POWER to leave parameter selection and return to control module selection.
8. Press the POWER to leave the menu. The unit will return to normal operation, if no button is pressed for more than 5 minutes.

2.4 How to select active alarms on outputs and special functions or weekdays in time schedules.

1. Select the alarm parameter of an output or a special function as described above. For example 1d06 or 1d07.
2. Press OPTION to start selecting the alarms. AL 1 is now shown in the large digits.
3. Press UP to select the alarm 1, press DOWN to deselect the alarm 1. A selected alarm is visible on OPA2, TCX2, SDC2, SOC2 and TC12 by a dark triangle on the bottom line of the LCD. For OPT1 and TRI2 the top line will indicate if the alarm is active or not only while AL1, AL2 is displayed on the large digits. The output or function will activate if the corresponding alarm is triggered.
4. Press OPTION to step to alarm 2. Repeatedly press the OPTION button to step through all available alarms and select or deselect them by pressing UP or DOWN.
5. Press POWER to leave the alarm selection routine and return to the parameter selection level.

3 Backup and restore of configuration

You can easily back up an X2 device's full configuration and restore it later. Use this feature to clone setups, update multiple controllers, or store safety copies of your standard configuration.

3.1 Backup Options

X2 devices can store and restore configuration data in two ways:

Storage Type	Description	Use When...
Internal memory ("Default")	Built-in backup space on the device.	You just want a quick local copy.
Plug-in memory (AEC-PM1 / AEC-PM2)	External memory module inserted into the device.	You need to copy or distribute configurations across multiple controllers.

3.2 Using Plug-In Memory (AEC-PM1 / AEC-PM2)

The plug-in memory unit allows easy duplication of setups between devices.

Series	Type of memory	Location of plug
TCX2	AEC-PM1	Right side outside of housing or behind OP-plug for newest generation.
TCI2	AEC-PM2	Behind OP-plug
TCV2	AEC-PM2	Behind OP-plug
SDC2, SOC2, SCC2	AEC-PM2	Lower right, inside of housing, cover must be opened to access
TRI2	AEC-PM2	On front of flush mounted part, LCD display must be removed to access. To initiate copy of data from TRI2 to AEC-PM2 an accessory called AEC-TRI is required.
SRD2	AEC-PM2	Lower right, inside of housing, cover must be opened to access

Tip:

Check the product installation guide for device-specific plug locations and removal procedures.

The memory can hold up to 4 individual parameter sets. It is easy for a site engineer to update a variety of standard installations or for an OEM to program his standard setup based on application in the modules.

3.3 LED Indicators and Reset Button

Features	Power-LED	Data-LED	Boot button
AEC-PM1	Yes	Yes	No
AEC-PM2	No	Yes	Yes

Power LED shows connection status (AEC-PM1 only).

Data LED lights for ~5 seconds after a successful copy.

On AEC-PM2, pressing the boot button restarts the controller and triggers auto-load if enabled.

3.4 Auto-Load Function

If auto-load is enabled, the X2 device automatically loads the plugged-in memory configuration during startup.

This feature allows non-technical staff to update units simply by powering them on with the plug inserted.

3.5 Copying Parameter Sets

Steps

1. Log in to Engineering parameters (password 241).
2. Navigate to menu item **COPY**.
3. Select the source (data to copy from):
 - RUN – Active (runtime) memory
 - DFLT – Default (internal) memory
 - EEP1-4 – Plug-in memory folders
4. Select the destination (data to copy to).
5. Confirm selection.
6. The display shows source → target (e.g., 1to3 = runtime → EEP1).
7. Choose YES or AUTO to start.
8. AUTO enables automatic load after power-up.
9. Wait until PEND disappears.

Result Messages

Result	Meaning	Action
Good	Copy successful (Data LED flashes for 5s).	None.
Err5	Communication issue.	Check module connection or replace memory.
Err6	Checksum mismatch.	Data corruption –re-write memory.

3.6 Automatic Address Increase (for Large Projects)

If parameter CO15 = 01 or 03, the controller automatically updates and writes a new address to the plug-in memory after each successful copy. This avoids manual re-addressing during batch programming.

3.7 Using EasySet™ on a PC

You can also read or write parameter sets directly using Vector Controls' PC software.

Requirements

- EasySet™ installed on your computer (download free at)
- USB/RS485 converter

Connection Steps

1. Connect the converter to your PC and to terminals OP3 (+) and OP4 (-) on the device.
2. If an OPA2-VC is connected, unplug it first.
3. Start EasySet™ and select the correct COM port.
4. Choose Read Parameters or Write Parameters as needed.

Now you can:

- Save configuration files on your PC.
- Email or archive parameter sets for later reuse.
- Quickly upload a standard setup to any controller.

Helpful Notes

 Tip: For multi-controller projects, combine EasySet™ with an AEC-PM2 plug-in to automatically load standard configurations during startup.

 Warning: Disconnect power before inserting or removing plug-in modules to prevent data loss or device damage.



EasySet may be downloaded free of charge from our website www.vectorcontrols.com.

4 User and display settings

4.1 Controlling end user access

X2 devices allow various ways to control end user and expert access.

Parameters UP00 to UP04 control access to operating modes, set points, manual control of fan speeds, heat cool changes and time settings.

4.2 Defining the operation mode after power up

The parameter UP05 controls in which state the device will be after a return of power.

0 will always start up the device in OFF mode

1 will always start up the device in ON mode

2 will use the last known state of the device before removal or power. This is as well the default setting.

4.3 Occupied / unoccupied mode

If parameter UP06 is set to ON occupied/unoccupied mode change is enabled. This has the following effect:

Pressing the power button for less than 2 seconds in normal mode will then toggle between the unoccupied/ occupied mode.

Occupied mode is visualized with the symbol of a person inside a house, unoccupied mode with the symbol of the person outside the house.

Each control loop will change the setpoint based on its setting, allowing for less energy consumption in the unoccupied mode. These options are to use a fixed unoccupied setpoint or shift the occupied setpoint down in heating or up in cooling mode.

Pressing the power button longer than 2 seconds will set the device to OFF mode.

If parameter UP06 is set to OFF, unoccupied mode is not enabled. Pressing the power button once will toggle ON and OFF mode. There is not house symbol on the LCD to indicate operation mode.

In OFF mode, OFF is written on the small digits of the display. The active inputs and the clock if active are displayed on the large digits in a continuous cycle. Each having a display time of 3 seconds.

4.4 Idle display

The idle display is shown if no button is being pressed for more than 30 seconds.

To enable the idle display set UP08 = ON. If UP08 = OFF, the display will just remain in its last state.

The content of the idle display can be configured with UP09 – UP14 where the contents of the small and large digits and the side bar may be chosen. UP09, UP11, UP13 selects the type: input, output, setpoint, clock. With UP10, UP12, UP14 the index of the in-, output or control loop is chosen.

Example:

- UP09 = 1, UP10 = 3 -> UI3 is shown on the large digits
- UP11 = 2, UP12 = 1 -> LP1 set point is shown on the small digits
- UP13 = 3, UP14 = 1 -> AO1 is shown on the vertical bar

With UP15 the controller heat/cool symbol can be activated or deactivated in the idle display.

4.4.1 Show all enabled inputs

It is possible to show all enabled inputs (0xu0 ≠ 0) on the idle display. Every enabled input will be shown for 4 seconds. This function can be configured with UP09-UP12.

- UP09 / UP11 = 1 (Input)
- UP10 / UP12 = 0 (all inputs to be shown)

Note for SRD2:



If this configuration is chosen for the large digits (UP09/UP10), a separate view will show up where all enabled inputs are shown instead of the X2 idle display. All enabled inputs are shown, with a maximum of 4 inputs per page. With UP12, selection of automatic screen change in 4 second cycles or screen change on button press can be selected.

Note for all other X2 devices:



If an input is already assigned to be shown on the small or large digits, it will not be shown on the other digit row where "all" enabled inputs are shown.

Example when UI1 to UI4 are enabled:

- UP09 = 1, UP10 = 1 -> UI1 is shown on the large digits
- UP11 = 1, UP12 = 0 -> All other enabled inputs are shown in the small digits (UI2, UI3, UI4 alternating every 4 seconds)

4.5 Showing no current value in control loops

In normal operation while in control loop mode, the large digits show the current value of the controlled input, while the smaller digits show the acting setpoint of the control loop. Should the client wish to now see the current value, just set UP20 to ON. This will replace the current value on the large digits with the setpoint value. The small digits will then be not visible.

4.6 Fan-Coil mode

In case only one control loop is enabled, no outputs in manual mode and assigned to that control loop is one fan module, the device will automatically activate fan coil mode. In fan coil mode the right button will act as fan speed selector and the up/down buttons will change the temperature setpoint.

In case there is more than one loop or one output is in manual mode, the right button will work as selector button and fan or setpoints need to be changed using the up or down keys while their selection is active.

4.7 Celsius/Fahrenheit and altitude in m/ft

UP07 toggles Fahrenheit / Celsius and altitude settings.

Note: changing this setting will affect all temperature related parameters and altitude (UP29).

While Fahrenheit is active, the setpoint step width is doubled. If in Celsius mode the step width is 0.5 it is 1.0 for Fahrenheit.

UP29 is introduced to allow for setting the elevation in steps 50 m or 50 ft. UP29 is represented in [m] if UP07 = OFF and in [ft] if UP07 = ON. If UP07 is changed from OFF to ON, UP29 will be multiplied by 3 and vice versa divided by 3.

Note: UP29 influences dynamic pressure measurements, absolute humidity calculations (mixing ratio) and CO2 measurements.

4.8 12h/24 h clock display

UP17 changes clock display from 12h to 24h mode. In 12 h mode month will be listed before the day while the clock display shows the date. In 24h mode day will be before month.

4.9 Daylight saving

The daylight-saving feature is activated by UP21 and uses the following scheme:

At the last Sunday morning 2:00 in March the clocks are advanced one hour to 3:00 for summer time. On the last Sunday morning in October, they are put back at 3:00 to 2:00 for normal time.

4.10 Summer – Winter mode for setpoint limits

UP24 = on stands for winter mode and off for summer mode. This may be used for setpoint limits in control loops instead of defining those limits based on heating / cooling mode. This can be useful for 4-pipe systems where the limits are controlled by season and outdoor conditions not the current active sequence.

4.11 Control of backlight and blinking LED

With UP19 the backlight of a connected operation terminal may be constantly lit. Please observe that the quality of the temperature measurement may suffer with this feature activated for wall mounted operating terminals.

Some devices use a visible LED to indicate operation. This LED may be constantly turned on by setting UP23 to ON. This may be useful for networked controllers in order to identify a device mounted in a remote location.

4.12 Connecting one operation terminal to multiple controller

The operation terminal connection to a X2 device is basically a peer-to-peer connection of uninsulated RS485. It is therefore not really possible to have multi member communication network on this port. However, it is still possible to control multiple controllers with only one operation terminal. To do this one controller must be the master controller and connect all four conductors to the operation terminal. Additionally, it must have the no response parameter UP22 set to OFF.

As the connection is non-insulated, it is important that all controllers use a common ground. All slave controllers connect only the conductor OP3 and OP4 and have their UP22 parameter set to ON. These are now slave devices and they only listen to the operation terminal, without responding to it. They will execute all the commands but will not be able to display their output values or alarms on the screen of the terminal. Only the master device will achieve this.

In case no master device is active, the operation terminal will display a communication error.

In order to temporary communicate with single connected slave device, Press UP&DOWN key together while logged in parameter changing mode. The operation terminal can now again communicate with the slave device. This will cause unspecified results if multiple slave devices are connected.

4.14 UP Parameter reference UP 25 - UP 29

Parameter	Description	Range	Default
UP 25	<p>SRD2 – TFT (small screen) configuration. Select color scheme: 0 = White background, colorful text 1 = White background, black text 2 = Black background, colorful text 3 = Black background, white text</p> <p>SRD2–OP-TFT (large screen) configuration. Select color scheme: 0 = White background, black text 1 = Light-grey background, black text 2 = Dark Mode: Black background, white text 3 = Dark Mode: Blue-Grey background, white text 4 = Dark Mode: Teal (dark blue-green) background, white text 5 = Blue-Grey background, black text 6 = Green Background, black text</p>	0 - 15	1
UP 26	<p>SRD2 – IR sensor backlight dimming. Set brightness of backlight after PIR motion detection. 0 = OFF, 10 = Full brightness</p>	0 - 10	10
UP 27	<p>SRD2 – Application specific selection: 0 = Default</p>	0 - 255	0
UP 28	<p>SRD2 – Language selection 0 = English 1 = Deutsch 2 = Français 3 = Español 4 = Italiano 5 = 中国人 6 = Portugues</p>	0 - 6	0
UP 29	<p>Installation altitude (h = Height) If UP07 = OFF (°C) the value is in meters over sea level. Allowed range: 0...3000 m If UP07 = ON (°F) the value in feet over sea level. Allowed range is 0....9000 ft</p>	0...3000 h [m] 0....9000 h [ft]	0

5 Inputs

5.1 Input types

There are the following different input types for X2 devices:

- Sensor inputs internal: sensors that measure for example temperature, relative Humidity, CO2, Air quality.
- Universal1 inputs: Selectable with jumper for resistive temperature (NTC), VDC, mA signals
- Universal2 inputs: Selectable with jumper for resistive temperature (NTC), PT1000, VDC, mA signals
- Voltage inputs: VDC
- Passive inputs: RT/DI (resistive temperature sensor (NTC) or digital input)
- Passive infrared input: PIR
- Virtual inputs

There are no digital inputs in the X2 system. Physical inputs are available as analog or passive inputs.

The X2 operating system uses the term universal inputs UI for its parameters. In order to distinguish the different input types a fixed order is implemented:

The first group of inputs are always the internal sensors, followed by the analog inputs. The virtual inputs are always at the end.

5.1.1 Available inputs for different X2 products

The number of inputs available for a device is defined in its product datasheet. Here is an overview:

	TCX2-40863	TCX2-23343	TCX2-24273	TCX2-14050	TCI2-204.202	TRI2-221.202
UI1	Universal1	RT/DI	RT/DI	RT/DI	Universal2	Sensor
UI2	Universal1	RT/DI	RT/DI	RT/DI	Universal2	Sensor
UI3	Universal1	RT/DI	RT/DI	RT/DI	Universal2	Sensor
UI4	Universal1	VDC	RT/DI	RT/DI	Universal2	RT/DI
UI5	Universal1	VDC	VDC	Virtual 1	Virtual 1	RT/DI
UI6	Universal1	VDC	VDC	Virtual 2	Virtual 2	VDC
UI7	Universal1	Virtual 1	Virtual 1	Virtual 3	Virtual 3	Virtual 1
UI8	Universal1	Virtual 2	Virtual 2	Virtual 4	Virtual 4	Virtual 2
UI9	Virtual 1	Virtual 3	Virtual 3			Virtual 3
UI10	Virtual 2	Virtual 4	Virtual 4			Virtual 4
UI11	Virtual 3					
UI12	Virtual 4					

	TCV2-433.443	SxC2-200.101	SxC2-210.102	SRD2-220.103	SRD2-411.103	SRD2-212.002
UI1	P-Sensor	Sensor	Sensor	Sensor	Sensor	Sensor
UI2	RT/DI	Sensor	Sensor	Sensor	Sensor	Sensor
UI3	RT/DI	Sensor	Sensor	Sensor	Sensor	Sensor
UI4	RT/DI	Sensor	Sensor	Sensor	Sensor	Sensor
UI5	VDC	Sensor	Sensor	Sensor	Sensor	Sensor
UI6	VDC	Virtual 1	RT/DI	Sensor	Sensor	PIR
UI7	VDC (FB)	Virtual 2	Virtual 1	PIR	PIR	Universal1
UI8	Virtual 1	Virtual 3	Virtual 2	RT/DI	VDC	Universal1
UI9	Virtual 2	Virtual 4	Virtual 3	Virtual 1	Virtual 1	Virtual 1
UI10	Virtual 3		Virtual 4	Virtual 2	Virtual 2	Virtual 2
UI11	Virtual 4			Virtual 3	Virtual 3	Virtual 3
UI12				Virtual 4	Virtual 4	Virtual 4

5.1.2 Display range and display resolution

For each input the minimum and maximum display may be defined. For sensor inputs the range needs to be adjusted to the available range of that input. For a physical input it needs to match the sensors output range.

The selected range has an influence in the resolution of setting values of connected control loops:

Limiting the display range increases set point resolution. A range <25 provides set point steps of 0.1°C (0.2°F). A range <125 provides set point steps of 0.5°C (1°F). Larger ranges increase by 1.0 step. Square root input range (0xu3) has no influence.

Note: Fahrenheit and differential step widths are doubled

5.1.3 Averaging of measured values (low pass filter)

Filtering prevents unwanted fluctuation of sensor signals. The controller measures signal inputs every second and calculates the input signal based on a number of measured values and a digital low pass filter. Take into account that signal reaction delays as the number of samples taken for the filter increases.

Note: changing this value will as well change 0xu8

5.1.4 Mathematical functions

The following is true for the mathematical function of each physical input or inputs from operation terminals and plug-ins. The special input functions of the virtual inputs use a different logic.

Calculate mathematical functions over multiple inputs for loop control or display with xxU7. In order to calculate average, minimum or maximum between several inputs, make sure all the inputs are of identical type and range and then activate the same function on xxU7 on all the selected inputs. The largest input of the group selected will carry the calculated value. For example: When average is activated on 02U7 and 01U7 = 1, the average is carried on universal input 2.

UI2 may now be used as input for control loops and it will show the average value of UI1 and UI2 combined.

It is possible to use different functions on different inputs. For example: minimum of UI1 and UI3 and maximum of UI2 and UI4.

- ➔ The differential function may only be calculated on subsequent inputs. Such as UI2-UI1. The function must only be activated on the minuend (a number from which another number is subtracted) – UI2 in this example. The displayed value of the minuend will change into the difference: UI2 in – UI1 = UI2 out. It is possible to have multiple differentials on one controller. It is not possible to reverse the subtraction: UI1-UI2.

5.2 Sensor inputs internal (SxC2, TRI2, SRD2, TCV2 only)

These inputs are from sensors within the X2-device. These internal sensors measure temperature, relative humidity, CO₂, air quality or differential pressure. The internal sensor inputs directly measure a value and generate a signal in that value.

5.2.1 Assign an internal sensor to an input

A X2-device may contain a number of internal sensors. These sensors can be assigned to different inputs.



The available inputs for internal sensor signals may be found in the product data sheet and in this document in chapter "Available inputs for different X2 products" on page 12.

To assign an internal sensor to an input just set the parameter under 0xu0 to the corresponding number of the sensor.

Now this input will carry the signal of that sensor. This is the internal sensor selection:

- 0 = not active
- 1 = Temperature
- 2 = Relative Humidity
- 3 = Temperature from RH sensor
- 4 = VOC AQI (0 - 100)
- 5 = VOC CO₂ equivalent (ppm)
- 6 = CO₂ sensor (ppm)
- 7 = Differential pressure bidirectional e.g.: -200 - 200 Pa
- 8 = Differential pressure unidirectional e.g.: 0 - 200 Pa
- 9 = Dust sensor PM1.0, PM2.5, PM10 (µg/m³)
- 10 = Formaldehyde HCHO sensor (µg/m³)

5.2.2 Reading intervals

Each sensor type has a different reading interval. The intervals are different in order to reduce internal communication. This has an influence on the low pass filter. The reaction time is thus increased proportionally to the interval time.

- 0.1 second reading interval: temperature and pressure
- 1 second interval: VOC, relative Humidity and temperature from RH sensor
- 8 second interval: CO₂ and dust sensor

5.2.3 Multipliers and display ranges for internal sensors

The display range of a sensor may be reduced in order to increase resolution for setpoints and to match other inputs in case mathematical functions are used. See earlier chapters about this topic for further details.

Extending the range over the measuring range will not provide the correct results.

Note: Using multipliers for FW version 1.4 and earlier for non VOC or CO₂ sensors will provide incorrect results.

5.2.4 Special functions for humidity sensors

5.2.4.1 Anti creep mode for AES4 humidity sensors

If AES-type sensors are exposed to high humidity for a prolonged period, their substrate becomes saturated. This will result in a drift of the measured relative humidity. To combat this effect an anti-creep function is introduced with X2 version V1.7. This function will activate once a sensor is exposed to relative humidity values above 80% for 240 minutes.

Once this function is active, it will in a 5-minute interval, freeze the sensor value, heat the sensor internally to > 100 °C to drive out the moisture and restart measurement once the temperature has reached pre-conditioning levels.

The anti-creep mode is controlled with 0x u9. 0x u9 = 1 enables anti creep, 0x u9 = 0, disables anti creep.

Note: this function only works for AES4 type sensors and later on SDC2, SOC2 and SRD2 series.

5.2.4.2 Reconditioning for AES4 humidity sensors

AES humidity sensors are often susceptible to contamination by certain volatile organic compounds (VOCs) or prolonged exposure to high humidity. In principle, contamination can be successfully prevented by following recommended handling instructions. However, under certain conditions, VOCs can diffuse into the sensing polymer and influence the relative humidity signal. To remove contamination, the integrated on-chip heater of the AES4 sensor element can be used to outgas contaminating VOCs from the polymer.

This function is activated using 0x u8:

- 0x u8 = 0: OFF
- 0x u8 = 1: Reconditioning once for 10 minutes duration
- 0x u8 = 2: Reconditioning once for 60 minutes duration
- 0x u8 = 3: Reconditioning after each power cycle for 10 minutes duration

Note: this function only works for AES4 type sensors and later on SDC2, SOC2 and SRD2 series.

5.2.5 Special functions for CO2 sensors

5.2.5.1 Self-correcting ABC algorithm (Automatic Baseline Correction) for CO2 sensors

This algorithm constantly keeps track of the sensor's lowest reading over one week and slowly corrects for any long-term drift detected as compared to the expected fresh air value of 400ppm (or 0.04%vol) CO2. The maximal correction amount is 30 ppm per week. An initial error will thus offset itself after a couple of weeks of constant run time.

ABC algorithm should only be enabled if the CO2 level returns to 400 ppm or fresh air level at least once per week. For certain applications where this is not the case such as office rooms with 24/7 shift operation or animal farms, ABC must be disabled and the sensor should be manually calibrated every 2 years.

5.2.5.2 Manual calibration of CO2 sensor (1u 00 = 6 only)

Rough handling and transportation might result in a reduction of sensor reading accuracy. With time, the ABC function will tune the readings back to the correct numbers. Manual calibration may be applied in the event that one cannot wait for the ABC algorithm to cure any calibration offset or if ABC is disabled.

There are two calibration options

0x u9 = 2 which requires that the sensor is exposed to fresh air (400 ppm CO2)

0x u9 = 1 which requires the sensor measuring cell to be completely evacuated from CO2 e.g. by exposing it to Nitrogen or Soda Lime CO2 scrubbed air.

Calibration procedure:

1. Before changing 0x u9, expose the sensor element to either fresh air or nitrogen and make sure that the sensor environment is steady and calm.
2. Set 0x u9 = 1 for 0 ppm or 2 for 400 ppm calibration.
3. Press right and up buttons to change to 0x u8 to store the calibration setting.
4. Set 0x u9 = 3 to start the calibration stored.
5. Return to 0x u8 and wait for 5 seconds.

Check calibration status: If calibration was successful, it is 0x u9 = 0. If calibration failed it is 0x u9 = 7.

5.2.6 Zero-calibration of pressure Sensor

With the "Zero-calibration" function, it is possible to zero out a differential pressure that might be present at normal operation in a system. The "Zeroing" value is subtracted from the measurement at every sensor read. This allows for effective measuring the differential pressure in a system.

 For optimal accuracy, we recommend repeating the "Zeroing" of the pressure sensor every 12 months.

1. Open the SRD2 or SCC2 cover and power up the device.
2. Short press "ZERO" button on P-Sensor board.
3. For -P2 products: Status LED starts blinking.
For -P3 products: LED on P-Sensor board starts blinking.
4. Press "ZERO" button again.
5. After "Zeroing" is successful, LED lights up constant for 5 seconds.

If Zeroing is not successful (difference too large, signal not constant, etc) The LED blinks for 10 seconds in 1 second interval.

Note: If "ZERO" button is not pressed again, the sensor will return to normal operation after 10 seconds.

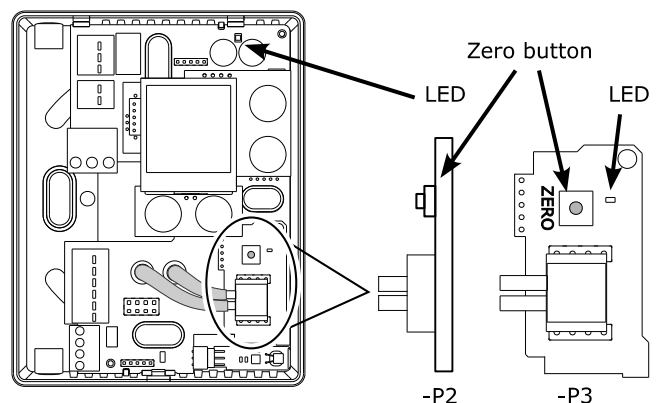

5.2.7 Altitude correction for dynamic pressure sensors

Dynamic pressure sensors require altitude correction. For example, the VAV controller TCV2 uses a dynamic pressure sensor. These sensors measure the airflow by a calculation method that measures the differential pressure caused by flowing air. As air density reduces with higher altitude, this plays a significant role with higher elevations. To correct this parameter **UP29** is introduced to allow for setting the elevation in steps 50 m or 50 ft.

Parameter reference for internal sensor inputs

Parameter	Description	Range	Default
0x u0	<p>For internal sensor inputs:</p> <ul style="list-style-type: none"> 0 = Not active 1 = Temperature interval: 1s 2 = Relative Humidity interval: 4s 3 = Temperature from RH sensor interval: 4s 4 = VOC AQI (0 - 100) interval: 8s 5 = VOC CO2 equivalent (ppm) interval: 8s 6 = CO2 sensor (ppm) interval: 8s 7 = Differential pressure bidirectional interval: 1s 8 = Differential pressure unidirectional interval: 1s 9 = Dust sensor PM1.0, PM2.5, PM10 (µg/m3) interval: 1s 10 = Formaldehyde HCHO sensor (µg/m3) interval: 1s <p><i>Note: all the signals only operate if the respective sensing element is installed.</i></p>	0 - 10	1
0x u1	Display minimum value.	-50 - 205	0
0x u2	Display maximum value.	-50 - 205	100
0x u3	<p>Range of universal inputs (For analog inputs only: 1u0 = 1,2):</p> <ul style="list-style-type: none"> 0 = x1 1 = x10 2 = x100 3 = Square root x1 only for pressure 4 = Square root x10 only for pressure 5 = Square root x100 only for pressure 	0 - 5	0
0x u4	Analog input unit: 0= no unit, 1= %, 2= °C /°F, 3= Pa	0 - 3	1
0x u5	Select number of samples taken for low pass filter	0 - 255	3
0x u6	Sensor calibration	Per input range	0.0
0x u7	<p>Calculate mathematical function over multiple inputs:</p> <ul style="list-style-type: none"> 0= off 1= average, 2= minimum, 3= maximum, 4= differential UI(n) - UI(n-1) 	0 - 4	0
0x u8	<p>For Humidity sensors (0x u0 = 2; AES4 only): Sensor Reconditioning</p> <ul style="list-style-type: none"> 0 = OFF 1 = Reconditioning once for 10 minutes duration 2 = Reconditioning once for 60 minutes duration 3 = Reconditioning after each power cycle for 10 minutes duration <p>For CO2 sensor (0x u0 = 6): ABC calibration:</p> <ul style="list-style-type: none"> 0 = ABC calibration active (default) 1 = ABC calibration not active. Set to 1 if room is 24/7 occupied. ABC calibration requires that the CO2 concentration return to fresh air level at least once per week. 	0 - 3	0
0x u9	<p>For Humidity sensors (0x u0 = 2; AES4 only): Anti-Creep (Prevent drift in high humidity)</p> <ul style="list-style-type: none"> 0 = Disabled 1 = Enabled <p>For CO2 sensor (0x u0 = 6) Calibration routine</p> <ul style="list-style-type: none"> 0 = off 1 = 0 ppm 2 = 400 ppm (fresh air) 3 = Calibration start 7 = Read only. Shows after calibration if calibration fails (calibration error) <p>For dust sensor (0x u0 = 9) Particle size. Output value in µg/m³</p> <ul style="list-style-type: none"> 0 = PM2.5 1 = PM1.0 2 = PM10 <p>For pressure sensors: ignore this value</p>	0 - 7	0

Note: 0x represents the index of the actual used internal sensor input 1 - n according to the X2 product.

5.3 Universal Inputs

These are the passive or analog inputs that can be connected to an X2 device. There is a hardware and software component to the sensor signals. The hardware part measures the signals. For universal inputs, the correct signal must be selected using jumpers. Analog or passive inputs may only deal with one type of input signal. To convert the measured value correctly the matching sensor input must be selected under the parameter Signal-Type.

5.3.1 Signal types

RT/DI:	For resistive temperature sensors that have a negative temperature coefficient (NTC). The type used is 10kΩ@25°C (77°F) or (10kΩ Type II). This sensor is most accurate between 0 - 50°C (32...122°F). Specified accuracy can only be guaranteed using Vector Controls Sxx-Tn10 sensors. Range values described above also apply to temperature inputs. Note: RT/DI inputs may as well be used to detect open contacts (DI – digital inputs) or potentiometer inputs. (See below)
PT1000:	A resistive sensor with a positive temperature coefficient. PT1000 is standardized to measure 1000Ω @ 0°C (32°F). It has quite a linear curve and is thus more useful for large temperature ranges.
VDC:	Voltage signal 0 - 10 or 2...10 VDC selectable with the input type parameter. 2-10 VDC inputs will be disabled if the detected voltage is less than 0.75 VDC.
mA:	The mA input accepts a current signal of 0 - 20mA or 4...20 mA selectable with input type parameter. 4...20 mA inputs are disabled if the detected current is less than 1.5 mA The input is not powered. An additional power supply is required to use 2 wire current sensor. Please check the wiring guide for the correct setup.
PIR:	Passive infrared sensor which can be used as motion detector (only available for SRD2)
Universal1:	Selectable with jumper between RT/DI, VDC or mA signals.
Universal2:	Selectable with jumper between RT/DI, PT1000, VDC or mA signals

New with V1.7!



2-10 VDC inputs will be disabled if the detected voltage is less than 0.75 VDC.
4-20 mA inputs will be disabled if the input current is less than 1.5 mA.
If this behavior is not wanted, switch to 0-10 V or 0-20 mA inputs.

5.3.2 Square root calculations on input values

The input signal maybe subjected to the square root function prior to calculating the display values. The square root is calculated from the input signal and the result is again conditioned to 10bit resolution. The square root function is useful when airflow needs to be calculated from differential pressure, as in VAV systems for example.

5.3.3 Open contact as input type

For an open contact input set the jumper to RT/DI and parameter 0xu0 to open contact (4 or 5). If set to 4 (open contact direct), an open contact reads as a high value (100%), a closed contact as a low value (0%). If set to 5 (open contact reversed), an open contact reads as low value (0%) and a closed contact as high value (100%).

Note: sensor calibration does not work for digital inputs.

5.3.4 Potentiometer input

A potentiometer may be connected to a passive input to control the setpoint of a control loop. With the input display minimum and maximum values the range of the potentiometer can be defined in 100 ohms steps. For example setting the 0xu1 to 50 and 0xu2 to 120 represents a potentiometer from 5k to 12k Ohm. The resistance is measured and calculated into a 0 - 100% value. Based on the potentiometer input, the setpoint will now be moved between the upper and lower setpoint limits of the control loop. There are other uses for the potentiometer input. For example, the controller can be enabled and disabled remotely with a potentiometer using an input in potentiometer mode assigned to the Auxiliary Function Enable/Disable (1FU). Or use Alarm/Interlocks assigned to the potentiometer input to activate or deactivate outputs. With the potentiometer fully on, for example, another interlock could activate a boost mode. The potentiometer could then read OFF (65°F) to Full (85°F). Add one more wire connected to a 10k-2 resistor and measure the room temperature as well. Thus with 3 wires in total (potentiometer, common, room temperature) a well-functioning low-cost operation terminal may be realized.

5.3.5 Light control mode: toggle and dimmer switch or motion detection

Toggle switch

The toggle switch mode is enabled if a digital output is assigned to a light control mode input.

Lights can be controlled by using push-button switches in the room connected to the passive inputs. A passive input is assigned directly to an output connected to a relay for the light. The output will switch on when the input is on and switch off when the input is off or the timeout expires (0xu8). Configure toggle switch mode by setting D01 to 9 and choosing the corresponding input with D09. Additional to this the on and off limits may be defined with D14/D15. Set D14 to 10% and D15 to 8%. This will activate the output once the input signal is larger than 10% and deactivates it if it is less than 8%.

Dimmer switch

The dimmer switch mode is enabled if an analog output and a digital output are assigned to a light control mode input. An analog output is assigned directly to an input by assigning xA00 to 7. Pressing the push-button switch for less than 2 seconds will toggle the digital output (switch on/off the light). For dimming, pressing the push-button switch for longer than 2 seconds will change the input value by 10% per second from 0% to 100% and again back to 0%.

Automatic switch off

Lights can also be switched off automatically when used for example with a motion sensor or staircase pulse switches. When the contact is activated, the light turns on, and it turns off after the configured timeout expires. The timeout is configured with parameter xu08. Setting the timeout to 0, deactivates the auto-switch-off.

5.3.6 Pulse counting mode

- ➔ With this feature it is possible to count pulses from a water or energy meter and summarize a constant value or the result of an input.
- ➔ For frequent pulses the summary option of 0xu5 is recommended. This will save only every 10th 100th or 1000th pulse to the EEPROM and keep the values until then in RAM. This bears the risk that those values will not be remembered after a power failure.
- ➔ With 0xu7 the value of two inputs may be used in conjunction with the Pulse Counting Input to calculate energy consumption. For example, apply the Mathematical Function-Differential to supply and return water temperature for a heating system. The calculated value of a series of inputs is shown on the input with the higher number. When UI1 supply water temperature and UI2 return water temperature both have Mathematical Function-Differential parameter selected the difference between supply and return temperature will be shown on UI2. When the Pulse Counting input parameter 0xu7 is set to 2, the difference between supply and return temperature is added to the total at each pulse of the flow meter. This total then represents energy consumption.

Parameter	Description	Range	Default
0x u2	Value to be added with each pulse. For single pulse counting set to 1. This value will only be used if 0xu7 = 0.	-50 - 205	1
0x u5	Save value to EEPROM, only after every n sample will the data be saved to EEPROM. The EEPROM allows for 100'000 guaranteed saves. In order to guarantee reliable operation this multiplier should be set to prevent premature aging of the controller. 0 = 1 every sample is saved. 1 = 10 after 10 samples data is saved to the EEPROM 2 = 100 after 100 samples data is saved to EEPROM 3 = 1000 after 1000 samples data is saved to EEPROM	0 - 3	0
0x u6	Reset counter: any value other than 0 will reset the counter. Once this value is set to 1 and saved, the counter will be reset to 0 immediately.	0 - 255	0
0x u7	Select Input whose value is used to be added with each pulse.	0 - 12	0

Note: 0x represents the index of the actual used input 1 - n according to the used X2 product.

5.3.7 Parameter reference for universal inputs

Parameter	Description	Range	Default
0x u0	0 = Not active 1 = 0 - 10 VDC / 0...20 mA VDC/mA 2 = 2-10 VDC / 4...20 mA (disabled if signal < 0.75 VDC or 1.5 mA) RT/DI 3 = NTC RT/DI 4 = open contact direct (contact open = 100%, closed = 0%) RT/DI 5 = open contact reversed (contact open = 0%, closed = 100%) RT/DI 6 = potentiometer input, assign to setpoint selection of control loop RT/DI 7 = light control mode: toggle and dimmer switch or motion detection RT/DI 8 = pulse counting input. RT/DI 9 = PT1000 input (only if available: e.g. TC12)	0 - 9	1
0x u1	Display minimum value. See note below about display resolution. For potentiometer input: lower range limit of potentiometer in 100 Ohm steps only if 0xu0 = 6: if minimum value is higher than maximum value, the input signal is reversed. 0% input = 100% signal, 100% input = 0% signal	-50 - 205	0
0x u2	Display maximum value. See note below about display resolution. For potentiometer input: Upper range limit of potentiometer in 100 Ohm steps only if 0xu0 = 6: if minimum value is higher than maximum value, the input signal is reversed. 0% input = 100% signal, 100% input = 0% signal	-50 - 205	100
0x u3	Range of universal inputs (For analog inputs only: 0xu0 = 1,2) 0 = x1 3 = square root 1 = x10 4 = square root x 10 2 = x100 5 = square root x 100 only if 0xu0 = 7: Light switch mode: 0 = Light switch (toggle or dimmer) 3 = Motion Detection	0 - 5	0
0x u4	Analog input unit: 0= no unit, 1= %, 2= °C /°F, 3= Pa	0 - 3	1
0x u5	When 0xu0 = 1-5: Select number of samples taken for low pass filter: <i>Note: Linked parameter: changing this parameter will as well change 0xu8</i>	0 - 255	3
0x u6	Sensor calibration	Per input range	0.0
0x u7	Calculate mathematical function over multiple inputs (0=not active): 1= average, 2= minimum, 3= maximum, 4= differential UI(n) - UI(n-1)	0 - 4	0
0x u8	When 0xu0 = 7 (light switch), select auto switch off time. Set to 0, if output should not automatically switch off. <i>Note: Linked parameter: changing this parameter will as well change 0xu5</i>	00:00s...15:10h MM:SS...HH:MM	00:15 MM:SS

Note: 0x represents the index of the actual used input 1 - n according to the X2 product.
RT/DI = Resistive temperature sensor (NTC) or digital input.

5.4 Virtual inputs

These inputs are not located on the controller. They are inputs from a connected operation terminal, a bus-plug-in or a special function input.

5.4.1 Timeouts for remote inputs

The remote input has a selectable timeout. If the value is not updated within this timeout, the input will be disabled and the configuration error Err4 is shown. Rewriting the input value will re-enable the input but will not clear Err4. Err4 can only be cleared by acknowledgement through the right key. Setting the timeout to 0 disables its function. For control functions, the timeout should not be disabled.

While no additional setup is required on the OPA2, the bus master needs to write its value to the correct address for the input within the timeout period. Details are described in the documentation of the communication module.

5.4.2 Virtual inputs from operating terminals

Available inputs are temperature, relative humidity and 2 analog inputs. Which inputs are available for the operation terminal used, needs to be verified with its product datasheet.

To use these inputs with X2, it is only required to activate the operating terminal signal type on those respective virtual inputs.

The inputs are fixed assigned in the following way:

1. virtual input: temperature sensor
2. virtual input: RH (relative humidity) sensor
3. virtual input: analog input 1
4. virtual input: analog input 2

5.4.3 Touch buttons from operating terminals

Some operation terminals have touch buttons that can be assigned to inputs. These inputs can then be used to switch outputs or trigger interlocks. The touch buttons can be assigned to any virtual input by setting 0xu0 = 5. Those virtual inputs may be read and reset as well by communication plug-ins. The application for the button can be defined with 0xu4: 0 is for on/off conditions such as light switches, 1 is for dimming light switches (0 - 100% - on/off) and 2 is for blinds 0 - 100 % with end positions.

Automatic switch off

Touch button inputs can also be switched off automatically. When the contact is activated, the input turns on, and it turns off after the configured timeout expires. The timeout is configured with parameter xu08. Setting the timeout to 0, will deactivate it.

5.4.4 AEI accessory

Inputs from AEI accessories: This new feature allows the use of accessories to expand the number of physical inputs for X2 devices. The ID of the input is fixed assigned to the virtual inputs. The first physical input on the AEI is as well the first virtual input. The type of input is selected with u5. The timeout is fixed to 1 minute for these types of inputs. So for example on TCX2-40863, UI9 = Input 1 of AEI-4UI and UI12 = Input 4 of AEI-4UI.

5.4.5 Virtual inputs from communication-plug-ins

AEX-BAC, AEX-MOD and other plug-ins may be used by a gateway or server to write to the virtual inputs.

This way an outdoor sensor may be shared between different X2 devices. The X2 device may not directly write the sensor signal to another X2 device. It is only possible by an upper level controller which is programmed to read a sensor value and on defined intervals write the value to the virtual inputs of the devices that require that signal.

5.4.6 Virtual inputs in special function mode

Those inputs calculate a signal from up to two other sources. The sources may be another input, an output, a sequence or an interlock. It is possible to calculate results using mathematics or a signal such as dew point or enthalpy.

5.4.7 Parameter reference virtual remote inputs

Parameter	Description	Range	Default
0x u0	For virtual inputs: Select signal source 0 = Not active 1 = Operation terminal OPA2-VC, OPU2-2TH-VC, etc. 2 = Bus module: AEX-MOD (Modbus), AEX-BAC (BACnet) 3 = Special input functions (configuration, see next page) 4 = Inputs from accessories such as AEI-4UI 5 = Touch button (operating terminal)	0 - 5	0
0x u1	Display minimum value	-50 - 205	0
0x u2	Display maximum value	-50 - 205	100
0x u3	Range of inputs (For analog inputs only) 0 = x1, 1 = x10, 2 = x100	0 - 2	0
0x u4	If u0 = 1 - 4: Analog input unit of measure: 0= no unit, 1= %, 2= °C /°F, 3 = Pa If u0 =5 touch button. Unit is fixed to % 0 = On/Off Light switch 1 = Dimmer light switch (0 - 100 %) 2 = Blinds operation (0 - 100 %) 3 = Motion sensor from remote operating terminal OPD2 (PIR)	0 - 3	2
0x u5	If u0 = 4: Select type of input for AEI 0 = not active 1 = 0 - 10V 2 = 2-10V 3 = NTC 4 = open contact direct (contact open = 100%, closed = 0%) 5 = open contact reversed (contact open = 0%, closed = 100%) 6 = potentiometer input, assign to setpoint selection of control loop <i>Note: linked parameter: changing this parameter will change as well 0xu8</i>	0 - 7	1
0x u6	Sensor calibration	Per input range	0.0
0x u7	Calculate mathematical function over multiple inputs (0=not active): 1 = average, 2= minimum, 3= maximum, 4= differential UI(n) - UI(n-1)	0 - 4	0
0x u8	If u0 = 2: Select timeout: If the value is not updated within the specified time period, the input will be disabled. If the input is assigned to an active control loop or a function configuration error Err4 is shown. If u0 = 5: (touch button), select auto switch off time. Set to 0, if output should not automatically switch off. <i>Note: linked parameter: changing this parameter will change as well 0xu5</i>	00:00s...15:10h MM:SS...HH:MM	01:00 MM:SS

Note: 0x represents the index of the actual used input 1 - n according to the X2 product.

5.5 Special function input configuration

A virtual input configured as special input function calculates its signal based on selected inputs and functions. These functions may be additions, subtractions, minimum, maximum, dew point and enthalpy.

Note: The multiplication function also works with differential inputs (e.g. used for differential pressure sensors). All other special functions only work with non- differential inputs.

5.5.1 Calculations with different input and output types

An input to a special input function can be a physical input, a virtual input, a control sequences or an output. It is possible to compare sequences with physical inputs or outputs.

All sequences and outputs are calculated as 0 - 100%. Fan outputs are based on active step: 0%/33%/66%/100%

The inputs do not have to use same display range as in the mathematical functions of each input. The function calculates absolute values. It is also possible to calculate inputs with different multipliers.

5.5.2 Enthalpy, dew point

For the enthalpy, dew point function the temperature input needs to be on input 1 and the humidity on input 2. The permissible input signal range for temperature is from 0.1 to 80°C (32.5 to 176 °F) and from 0 to 100% for relative humidity. If the signal is outside of this range, the minimum or maximum values will be used instead.

If °C is active all the units follow the metric convention: for Enthalpy it is kJ/kg. If °F Fahrenheit is active, imperial units are used. Enthalpy is in BTU/lb.

5.5.3 Absolute humidity (mixing value)

Absolute humidity sometimes referred to as mixing value in g/kg or gr/lb the temperature input needs to be on input 1 and the humidity on input 2. The permissible input signal range for temperature is from 0.1 to 80°C (32.5 to 176 °F) and from 0 to 100% for relative humidity. If the signal is outside of this range, the minimum or maximum values will be used instead.

Absolute Humidity (mixing value) is calculated in g/kg. If gr/lb is required, the result needs to be multiplier with factor 7 using the multiplication formula.

Absolute humidity or mixing value depends on the absolute air pressure to be accurate. Therefore, the installation altitude needs to be defined with UP29. UP29 is in m if °C is active and ft if °F is defined.

5.5.4 Thermodynamic function for refrigerants

It is now possible to convert pressure to temperatures for a variation of fluids used in refrigeration. The input is a pressure value in kPa, PSIA or PSIG with a range from 0 - 2000kPa, 0 - 300 PSIA or -14.7 to 285.3.

Select the unit of the pressure sensor with u8. U8 = 0 uses kPa, U8 = 1 expects PSIA.

The output is the temperature for the medium chosen. These calculations are useful for refrigeration applications such as superheat or supercool controllers. Let us know if pressure – temperature functions are needed for other refrigerants.

Note: Thermodynamic functions are not available for pressure sensor products.

5.5.5 Multiplication of input values

Use the parameters u8/u9 to multiply an input value chosen with u6/u7. The multiplier consists of a whole number (u8) and a decimal place (u9) value. For example, a multiplier of 12.34 can be set with u8 = 12 and u9 = 34.

Use the parameter u3 to set the resolution:

- u3=0: The maximum result of the multiplication is 6'553.5 with a resolution of 0.1
- u3=1: The maximum result of the multiplication is 65'535 with a resolution of 1
- u3=2: The maximum result of the multiplication is 655'350 with a resolution of 10

Example 1: Factor 12.34

Settings
0x u0 = 3 (Special input function)
0x u1 = 0 min value
0x u2 = 100 max value
0x u3 = 0 (result resolution of 0.1)
0x u5 = 10 (Multiplication)
0x u6 = 0 (physical or virtual input)
0x u7 = 1 (Input 1)
0x u8 = 12 (Most significant number)
0x u9 = 34 (Least significant decimal)

Example 2: Factor: 12345

Settings
0x u0 = 3 (Special input function)
0x u1 = 0 min value
0x u2 = 100 max value
0x u3 = 1 (result resolution of 1)
0x u5 = 10 (Multiplication)
0x u6 = 0 (physical or virtual input)
0x u7 = 1 (Input 1)
0x u8 = 123 (Most significant Number)
0x u9 = 45 (Least significant decimal)

Example 3: Factor 123450

Settings
0x u0 = 3 (Special input function)
0x u1 = 0 min value
0x u2 = 100 max value
0x u3 = 2 (result resolution of 10)
0x u5 = 10 (Multiplication)
0x u6 = 0 (physical or virtual input)
0x u7 = 1 (Input 1)
0x u8 = 123 (Most significant Number)
0x u9 = 45 (Least significant decimal)

It is also possible to combine the square root function with the multiplication function.

Example to **calculate the air flow from differential pressure in VAV applications:**

- Use the example above and Configure an UI/SI as differential pressure. Choose the correct UI number with 0xu7
- Change 0xu3 = 3 ... 5 to enable the square root function as the air flow depends on \sqrt{P}
- Set the multiplication value with 0xu8 and 0xu9 (=K-Value) until the VI result corresponds with the reference air flow

5.5.6 Display of low, medium and high level (Air-quality, Temperature, Humidity) – SRD2 only

The SRD2 with display can also be used as a CO₂, VOC, temperature or humidity monitoring system.

In the idle screen, a monitoring bar shows the input value with an arrow. The bar is colored according to the selected color scheme. The arrow below the monitoring bar moves continuously between 0xu1 (low limit) and 0xu2 (high limit) according to the monitored input value. For the humidity and temperature color schemes, low limit and high limit define the outer limits of the green portion of the bar. In addition, an optional smiley icon in the idle screen can also highlight the corresponding level.

Parameters 0xu6 and 0xu7 can be used to select the input to which the function should be applied.

Note: The monitoring bar or smiley icon can only be displayed in the idle screen, see notes for user settings on SRD2 idle display. The unit of the limits is the same as used by the selected function input (0xu7).

Example 1: Temperature level

Settings
0xu0 = 3 (Special input function)
0xu1 = 18°C (Low limit)
0xu2 = 26°C (High limit)
0xu3 = 0 (x1)
0xu5 = 11 (Low, medium, high level)
0xu6 = 0 (physical or virtual input)
0xu7 = 1 (Input 1)
0xu8 = 2 (Temperature)
0xu9 = 1 (Show smiley symbol)

Example 2: CO₂ level

Settings
0xu0 = 3 (Special input function)
0xu1 = 80 (= 800 ppm: Low limit)
0xu2 = 120 (= 1200 ppm: High limit)
0xu3 = 1 (x10)
0xu5 = 11 (Low, medium, high level)
0xu6 = 0 (physical or virtual input)
0xu7 = 3 (Input 3)
0xu8 = 1 (Air quality)
0xu9 = 1 (Show smiley symbol)

Example 3: Humidity level

Settings
0xu0 = 3 (Special input function)
0xu1 = 35% (Low limit)
0xu2 = 65% (High limit)
0xu3 = 0 (x1)
0xu5 = 11 (Low, medium, high level)
0xu6 = 0 (physical or virtual input)
0xu7 = 2 (Input 2)
0xu8 = 3 (Humidity)
0xu9 = 1 (Show smiley symbol)

Small screen (SRD2-OP/OPIR)

Level	Displayed value	Smiley icon	colour
Low	< 18°C	☹	blue
Medium	18 – 20°C 24 – 26°C	☺	green
	20 – 24°C	☺	
High	> 26°C	☹	red

Level	Displayed value	Smiley icon	colour
Low	< 800 ppm	☺	green
Medium	800 – 1200 ppm	☺	orange
High	> 1200 ppm	☹	red

Level	Displayed value	Smiley icon	colour
Low	< 35%	☹	orange
Medium	35 - 42% 58 - 65%	☺	green
	43 - 57%	☺	
High	> 65%	☹	blue

Large Screen (SRD2-TOP/TOPIR)

Level	Displayed value	Smiley icon	colour
Low	< 18°C	☹	blue
Medium	18 – 20°C 24 – 26°C	☺	violet
	20 – 24°C	☺	
High	> 26°C	☹	red

Level	Displayed value	Smiley icon	colour
Low	< 800 ppm	☺	green
Medium	800 – 1200 ppm	☺	orange
High	> 1200 ppm	☹	red

Level	Displayed value	Smiley icon	colour
Low	< 35%	☹	orange
Medium	35 - 42% 58 - 65%	☺	violet
	43 - 57%	☺	
High	> 65%	☹	blue

5.5.7 Parameter reference for special function input

Parameter	Description	Range	Default
0x u0	For virtual inputs: 7U to 10U: Select signal source 0 = Not active 1 = Operation terminal OPA2-VC, OPU2-2TH-VC, etc. see previous 2 = Bus module: AEX-MOD (Modbus), AEX-BAC (BACnet), see previous 3 = Special input function 4 = Inputs from accessories such as AEI-4UI, see previous	0 - 4	3
0x u1	Display minimum value For 0xu5 = 11: (SRD2 only) Low activation limit (range according to selected input 0xu7)	-50 - 205	0
0x u2	Display maximum value For 0xu5 = 11: (SRD2 only) High activation limit (range according to selected input 0xu7)	-50 - 205	100
0x u3	Input Range 0x u3 = 3 ... 5: Available for multiplications only (0xu5 = 10) 0 = x1 3 = square root x 1 1 = x10 4 = square root x 10 2 = x100 5 = square root x 100	0 - 5	0
0x u4	Analog input unit of measure: 0= no unit, 1= %, 2= °C /°F; 3 = Pa	0-3	0
0x u5	Calculate mathematical or physical functions over multiple inputs: 0 = Off 1 = Average (input 1 + input 2)/2 2 = Minimum 3 = Maximum 4 = Difference (input 1 - input 2) 5 = Addition (input 1 + input 2) 6 = Dew point (input 1: temperature, input 2: relative humidity) 7 = Enthalpy of humid air (input 1: temperature, input 2: relative humidity) 8 = Absolute humidity [g/kg] (in 1: temperature, in 2: relative humidity) 9 = Thermodynamic conversion pressure to temperature with input in Pa or PSIA 10 = Multiplication with factor 11 = Low, Medium, High level (Smiley, color) function – SRD2 only	0 - 11	0
0x u6	Select type of function input 1 0 = universal and virtual inputs 1 = heating sequence of control loops 2 = cooling sequence of control loops 3 = heating & cooling sequence of control loops 4 = analog outputs 5 = digital outputs (0%, 100%) 6 = fan outputs (0%, 33%, 66%, 100%)	0 - 6	0
0x u7	For 0xu5 < 9: Select ID of function input 1	0 - 12*	0
0x u8	Select type of function input 2, see 0x u6 for listing	0 - 255	0
	For 0xu5 = 9: 0 for kPa, 1 for PSIA, 2 for PSIG		
	For 0xu5 = 10: Whole number value of multiplier (u8.u9) with range 0 - 255		
	For 0xu5 = 11: Color scheme (SRD2 only) 0 = No colors 1 = Air quality: Green (good air quality) to Red (bad air quality) 2 = Temperature: Blue (cold) to Red(hot) 3 = Humidity: Orange (dry) to Blue (wet/humid)		
0x u9	For 0xu5 < 9: Select ID of function input 2	0 - 99	0
	For 0xu5 = 9: Thermodynamics or refrigeration liquids: 0 = R717 (Ammonia) 1 = R290 (Propane) 2 = R744 (CO2) 3 = R22 4 = R134A 5 = R507		
	For 0xu5 = 10: (Multiplication with a factor) Decimal place value of the multiplier (u8.u9) with the range 0 - 99 \triangleq 0.00 - 0.99		
	For 0xu5 = 11: Smiley symbol (SRD2 only) 0 = Hide smiley symbol 1 = Show smiley symbol		

*) max input id depends on type of X2 product

Note: 0x represents the index of the actual used input 1 - n according to the X2 product.

6 Alarms and Interlocks

Alarms in X2 can be used to activate or deactivate functions, control loops and outputs. Each output may be configured to be fully on, fully off or for analog alarms output a specific value for each of the available alarms.

It is as well possible to disable the controller using alarms with the FU1 function. Free heating/cooling may be disabled using alarms in FU5.

There are different ways to activate an alarm: They are described in greater detail in the following pages:

- High or low limit alarm configuration
- Alarm based on maximum set point deviation of control loop
- Maintenance alarm based on run time counters
- Feedback or output alarms
- Alarms based on control loop sequence
- Timeout or cycle mode for outputs

6.1 Number and priority of available alarms.

8 alarms are available. The highest priority alarm is alarm 1, the lowest one is alarm 8.

6.2 Alarm conditions

An alarm may have the following conditions:

- Normal
- Alarm active
ALA1 – ALA8 is shown on the display. The system LED is blinking in 1 second interval.
- Alarm to be reset
ALA1 – ALA8 is shown on the display and blinking in one second interval. Such an alarm may be reset by pressing the RIGHT or OPTION key of the operation unit.

6.3 Alarm automatic reset or acknowledge only (AL4)

Certain alarms should automatically reset once the condition is removed, but still keep the end user informed that the alarm condition occurred: A typical example is a frost alarm. If the temperature drops too low, the heat should come on and it should stop again once the frost protection reset temperature is reached.

If an alarm indicates a failure of system equipment that would endanger the operation of a device, the alarm should not automatically reset. For example, when a fan fails to come on or a pump does not operate. In this case the alarm situation needs to be resolved before restarting the outputs.

By setting AL3 to ON the engineer determines that the alarm must be reset manually before normal operation can continue.

6.4 Alarm as Interlock (AL3)

An alarm may be defined as an interlock with AL3. As an interlock the alarm is silent, it will not be shown on a display device. It can not be acknowledged or reset. An interlock may thus be used to set outputs and loops to defined states depending on input or system conditions.

→ Operating the interlock in off mode:

To activate an interlock in OFF mode, set its AL4 value to ON. Make sure AL4 is set to OFF if the interlock should not activate an output while the controller is in OFF mode.

6.5 Alarm Settings on outputs

The position of an output in the event of an alarm may be defined for each output each alarm individually. The output can be switched on (100%) or off (0%). Additionally, analog outputs may now as well be set to a predefined value. To achieve this, the same alarm needs to be selected in the ON and OFF register. An additional parameter is provided to choose the desired alarm level.

Priority for output control

and

- | |
|--|
| <ol style="list-style-type: none"> 1. Alarm level low 2. Alarm level high 3. Operation mode OFF |
|--|

→ The alarm takes precedence over operating state and control signal. For interlocks, its operation during OFF mode is defined through parameter AL4.

→ Two parameters define the behavior of the output based on an alarm: One parameter defines which alarm deactivates the output (0%); the other parameter defines which alarm activates the output to 100%. Each alarm can be individually selected. Multiple alarms can be assigned to one output. Should an alarm be active simultaneously in the parameter to activate and another one to deactivate the output, the one to de-activate has precedence.

6.5.1 High or low limit alarm

The limit alarm activates if an input crosses a high or low limit.

For this type of alarms an input must be selected with AL2 and if this is a high or a low limit with AL6. The limit itself is defined with AL7. Once the input value crosses the limit defined the alarm delay starts counting.

If the delay expires and the condition is still true, the alarm becomes active.

If the limit is set to high (AL6 = ON), the input value must be higher than the limit in order to trigger the alarm.

If the limit is set to low (AL6 = OFF, the input value must be below the limit to activate the alarm.

6.5.2 Alarm reset

The reset determines when the alarm condition will return to normal.

The alarm reset is defined as hysteresis. The hysteresis defines the difference to the limit required to reset the alarm. For example, on a high limit alarm, the input value required to reset the alarm is the limit AL7 – hysteresis AL8.

For a low limit alarm, it is the limit AL7 + hysteresis AL8.

In frost protection for example. The frost protection alarm is activated once the temperature drops below 5°C (41°F), the alarm reset is set to 5K. The room is now heated until the temperature reaches 5°C (41°F) + 5K = 10°C (50°F). Once this temperature is reached the alarm will switch off, it will remain blinking until acknowledged.

6.5.3 Parameter reference for high or low limit alarm

Parameter	Description	Range	Default
xAL 0	Select alarm type: 0 = Alarm is not active 1 = Input high or low limit (select input in AL 2) 2 = Max. set point deviation of control loop (select loop in AL 1) 3 = Maintenance alarm from run time counters (select counter in AL 1) 4 = Feedback or output alarm for fan, supervise fan state (Select fan in AL 1) 5 = Feedback or output alarm for digital output (select output in AL 1) 6 = Feedback or output alarm for analog output (select output in AL 1) 7 = Level alarm or interlock for PI-sequence of control loop (select output in AL 1) 8 = Timeout or cycle mode for outputs. (select type in AL 2 and ID in AL 1)	0 - 8	1
xAL 1	Not used	0 - 8	0
xAL 2	Select supervised input if xAL0 = 1 0 = not active, input according hardware 1 = UI1 2 = UI2, etc.	0 - 12	0
xAL 3	Alarm or interlock mode OFF = Alarm mode active: Icon and the words ALA# on the small digits indicating active alarm will appear on display, reset option in xAL4 applies. ON = Interlock mode: Outputs revert to normal operation when alarm condition is no longer present, Icon and text indicating active alarm will not appear.	ON/OFF	OFF (Alarm)
xAL 4	Automatic reset or acknowledge to reset (only if AL3 = OFF) OFF = Alarm condition resets automatically. After alarm condition is no longer present, outputs will revert to normal operation, but alarm Icon will continue to blink on display until acknowledged with Option key. ON = Alarm condition must be reset manually. After alarm condition is no longer present, outputs will remain in alarm setting, and Icon will continue to show on display, until acknowledged with Option key. <i>Note: All alarms operate as well if the controller is in OFF mode.</i>	ON/OFF	OFF (Automatic reset)
	Select if interlock is active in OFF mode (only if AL3 = ON) OFF = Interlock is not active while controller is in off mode or disabled ON = Interlock is active independent of controller state		
xAL 5	Delay until alarm is active. Extended time range.	00:00s...252h MM:SS...HHH	00:00 MM:SS or h
xAL 6	Type of alarm (applies only if AL0 = 1, 7) OFF = Low limit alarm ON = High limit alarm	ON/OFF	OFF
xAL 7	Alarm limit for input-based alarms (applies only if AL0 = 1, 4 to 6 in feedback mode) <i>Note: linked parameter. Changing this parameter will as well change xAL9</i>	Per input range	10%
xAL 8	Hysteresis for alarm setback for input-based alarms (applies only if AL0 = 1) <i>Note: linked parameter. Changing this parameter will as well change xALA</i>	Per input range	5%
xAL 9	Not used	0 - 100%	8%
xAL A	Not used	0 - 100%	4%
xAL B	Sound alarm (SRD2, TRI2 and OPT1 only)	ON/OFF	OFF

Note: xAL represents the index of the actual used alarm 1 - n according to the X2 product.

6.6 Alarm based on maximum set point deviation of control loop

This alarm is used to determine a general failure of the control system. It may be assigned to one specific control loop or all control loop. The maximum allowed deviation parameter is defined in each control loop with xL26.

If the input does not reach the setpoint within the set point deviation parameter within the delay time defined with AL5 an alarm is generated.

6.7 Alarm based on run time counter (Maintenance alarm)

This alarm is used to schedule a maintenance action. It may be assigned to particular digital output with AL1 or if AL1 = 0 to all outputs. The limit for the maintenance alarm is defined in each digital output with D10. In order for the run time counter to work D09 must be set to ON and the output must be set as digital output.

6.7.1 How to reset a run time counter

Setting D09 to OFF and back to ON will set the counter to 0.

6.7.2 Parameter reference for maximum setpoint deviation and maintenance alarm

Parameter	Description	Range	Default
xAL 0	Select alarm type: 0 = Alarm is not active 1 = Input high or low limit (Select input in AL 2) 2 = Max. set point deviation of control loop (select loop in AL 1) 3 = Maintenance alarm from run time counters (select counter in AL 1) 4 = Feedback or output alarm for fan, supervise fan state (Select fan in AL 1) 5 = Feedback or output alarm for digital output (select output in AL 1) 6 = Feedback or output alarm for analog output (select output in AL 1) 7 = Level alarm or interlock for PI-sequence of control loop (select output in AL 1) 8 = Timeout or cycle mode for outputs. (select type in AL 2 and ID in AL 1)	0 - 8	2
xAL 1	For AL0 = 2: Select control loop <i>Note: max deviation limit is defined in control loop parameter (L26)</i> 0 = all active control loops (not valid if xAL0 = 7) 1 = loop 1 to 2 = loop 2	0 - 8	1
	For AL0 = 3: Select digital output for run time counter <i>Note: run time maintenance alarm limit is defined in digital output parameter d10.</i> 0 = all digital outputs 1 = Digital output 1 to 7 = Digital output 7		
xAL 2	Not used	0 - 10	0
xAL 3	Alarm or interlock mode OFF = Alarm mode active: Icon and the words ALA# on the small digits indicating active alarm will appear on display, reset option in xAL4 applies. ON = Interlock mode: Outputs revert to normal operation when alarm condition is no longer present, Icon and text indicating active alarm will not appear.	ON/OFF	OFF (Alarm)
xAL 4	Automatic reset or acknowledge to reset (only if AL3 = OFF) OFF = Alarm condition resets automatically. After alarm condition is no longer present, outputs will revert to normal operation, but alarm Icon will continue to blink on display until acknowledged with Option key. ON = Alarm condition must be reset manually. After alarm condition is no longer present, outputs will remain in alarm setting, and Icon will continue to blink on display, until acknowledged with Option key. <i>Note: All alarms operate as well if the controller is in OFF mode.</i>	ON/OFF	OFF (Automatic reset)
	Select if interlock is active in OFF mode (only if AL3 = ON) OFF = Interlock is not active while controller is in off mode or disabled ON = Interlock is active independent of controller state		
xAL 5	Delay until alarm is active. Extended time range.	00:00s...252h MM:SS...HHH	00:00 MM:SS or h
xAL B	Sound alarm (SRD2, TRI2 and OPT1 only)	ON/OFF	OFF

Note: xAL represents the index of the actual used alarm 1 - n according to the X2 product.

6.8 Feedback and output alarms

Feedback alarms are deployed to make sure a device is operating correctly. For example, to supervise a fan, feedback from a pressure sensor may be used. While the fan is in operation, the pressure measure through the sensor should be high, if the fan is off, the pressure should be low. If any of these conditions is amiss an alarm needs to be generated. Feedback-alarms normally should not reset themselves automatically, therefore the recommended setting for AL4 is ON.

To configure a feedback-alarm the output needs to be identified. This is done by selecting the type (AL0 = 4 for fan, AL0 = 5 for digital and AL0 = 6 for analog outputs. The actual output ID is specified with AL1.

6.8.1 Measuring the feedback response (direct or reverse)

Select the input to trigger the response with AL2. Now the response might be direct or reverse. If the response is direct, if the output is active, the input should be above the limit. If the output is inactive the input should measure below the limit.

If on the contrary the response is reverse, when the output is ON, the input goes low and if output is off, it goes high.

This is set with AL6. AL6 = OFF: direct feedback. AL6 = ON: reverse feedback.

The actual limit is set with AL7 with the hysteresis at AL8. This plays out the following way for a direct feedback relationship. The output goes active, the input must now go over the limit defined with AL7 within the time defined in AL5. Once the output goes inactive, the input must go below the limit defined with AL7 minus the hysteresis defined in AL8 within the time defined in AL5.

For a reverse relationship it works opposite. The output goes to active, the input must drop below the limit within the time limit. Once the output goes inactive the input must rise above the limit + hysteresis within the time, to prevent an alarm.

6.8.2 Output interlocks

Output alarms or interlocks can be used to activate an interlock based on the activation of, or exceeding the limit of, an output. A feedback alarm with no input assigned (AL2 = 0) will work as an output alarm or interlock.

To measure if the output is on or exceeds a certain level, AL9 and AL10 are used. Using AL6 determine if the alarm should be active while the output is on or off. (active while ON: AL6 = ON, active while OFF: AL6 = OFF)

For fan output alarms, each fan speed has a value of 10%. So speed 1 = 10%, speed 2 = 20% and speed 3 = 30%. To trigger an interlock or alarm based on fan speeds, the appropriate limits will have to be set using AL9 and AL10.

For digital outputs, the level is 100% when on and 0% when the output is off.

Analog outputs are according to their actual output level in % of the full span.

6.8.3 Parameter reference for feedback and output alarms

Parameter	Description	Range	Default
xAL 0	Select alarm type: 4 = Feedback or output alarm for fan, supervise fan state (Select fan in AL 1) 5 = Feedback or output alarm for digital output (select output in AL 1) 6 = Feedback or output alarm for analog output (select output in AL 1)	0 - 8	4 - 6
xAL 1	Select fan, digital or analog output if xAL 0 = 4, 5, 6, 8 0 = Interlock or alarm not active 1..x = selected output	0 - 8	1
xAL 2	Select supervised input or activate output alarm if xAL0 = 4, 5, 6: 0 = Output alarm, input according hardware, 1 = UI1, 2 = UI2, etc.	0 - 10	0
xAL 3	Alarm or interlock mode OFF = Alarm mode active: Icon and the words ALA# on the small digits indicating active alarm will appear on display, reset option in xAL4 applies. ON = Interlock mode: Outputs revert to normal operation when alarm condition is no longer present, Icon and text indicating active alarm will not appear.	ON/OFF	OFF (Alarm)
xAL 4	Automatic reset or acknowledge to reset (only if AL3 = OFF) OFF = Alarm condition resets automatically. ON = Alarm condition must be reset manually.	ON/OFF	OFF (Automatic reset)
	Select if interlock is active in OFF mode (only if AL3 = ON) OFF = Interlock is not active while controller is in off mode or disabled ON = Interlock is active independent of controller state		
xAL 5	Delay until alarm is active. Extended time range.	00:00s...252h MM:SS...HHH	00:00 MM:SS or h
xAL 6	For feedback alarms: AL2 ≠ 0: Type of feedback (applies only if AL0 = 4, 5, 6, 8) OFF = Direct: Output on, feedback high, ON = Reverse: Output on, feedback low For output alarms: AL2 = 0. OFF = Low limit: Output OFF, Alarm ON, ON = High limit: Output ON, Alarm ON.	ON/OFF	OFF
xAL 7	Alarm limit for input-based alarms (applies only if AL0 = 1, 4 to 6 in feedback mode) <i>Note: linked parameter. Changing this value will change as well xAL9</i>	Per input range	10%
xAL 8	Hysteresis for alarm setback for input-based alarms (applies only if AL0 = 1) <i>Note: linked parameter. Changing this value will change as well xALA</i>	Per input range	5%
xAL 9	Alarm limit for sequence based alarms (applies only if AL0 = 4 to 6 in output mode, 7) <i>Note: linked parameter. Changing this value will change as well xAL7</i>	0 - 100%	8%
xAL A	Hysteresis for alarm setback for sequence based alarms (applies only if AL0 = 4 to 6 in output mode or 7) <i>Note: linked parameter. Changing this value will change as well xAL8</i>	0 - 100%	4%
xAL B	Sound alarm (SRD2, TRI2 and OPT1 only)	ON/OFF	OFF

Note: xAL represents the index of the actual used alarm 1 - n according to the X2 product.

6.9 Alarms based on control loop sequence

This feature may be used to activate an alarm or an interlock if a PI-sequence of a control loop exceeds a certain level. This may be used to control an output through several control conditions in parallel when applied as interlock, or to indicate a malfunctioning control setup when used as alarm.

6.9.1 Limits for PI-loop sequence alarm

Use limits AL9 and ALA (AL10) to define limit and hysteresis for alarms or interlocks for PI sequences.

AL6 determines if the alarm should be set when the PI sequence is higher than the limit (AL6 = ON) or lower than the limit (AL6 = OFF).

6.9.2 Parameter reference for alarms based on control loop sequence

Parameter	Description	Range	Default
xAL 0	Select alarm type: 0 = Alarm is not active 1 = Input high or low limit (Select input in AL 2) 2 = Max. set point deviation of control loop (select loop in AL 1) 3 = Maintenance alarm from run time counters (select counter in AL 1) 4 = Feedback or output alarm for fan, supervise fan state (Select fan in AL 1) 5 = Feedback or output alarm for digital output (select output in AL 1) 6 = Feedback or output alarm for analog output (select output in AL 1) 7 = Level alarm or interlock for PI-sequence of control loop 8 = Timeout or cycle mode for outputs. (select type in AL 2 and ID in AL 1)	0 - 8	0
xAL 1	Select control loop if xAL 0 = 2,7, <i>Note: max deviation limit is defined in control loop parameters</i> 0 = all active control loops (not valid if xAL0 = 7) 1 = loop 1 to 2 = loop 2	0 - 8	0
xAL 2	Select sequence if xAL0 = 7 0 = heating or reverse 1 = cooling or direct 2 = heating and cooling or reverse and direct	0 - 10	0
xAL 3	Alarm or interlock mode OFF = Alarm mode active: Icon and the words ALA# on the small digits indicating active alarm will appear on display, reset option in xAL4 applies. ON = Interlock mode: Outputs revert to normal operation when alarm condition is no longer present, Icon and text indicating active alarm will not appear.	ON/OFF	OFF
xAL 4	Automatic reset or acknowledge to reset (only if AL3 = OFF) OFF = Alarm condition resets automatically. After alarm condition is no longer present, outputs will revert to normal operation, but alarm Icon will continue to blink on display until acknowledged with Option key. ON = Alarm condition must be reset manually. After alarm condition is no longer present, outputs will remain in alarm setting, and Icon will continue to blink on display, until acknowledged with Option key. <i>Note: All alarms operate as well if the controller is in OFF mode.</i>	ON/OFF	OFF
	Select if interlock is active in OFF mode (only if AL3 = ON) OFF = Interlock is not active while controller is in off mode or disabled ON = Interlock is active independent of controller state		
xAL 5	Delay until alarm is active. Extended time range.	00:00s...252h MM:SS...HHH	00:00 MM:SS or h
xAL 6	Type of alarm (applies only if AL0 = 1, 7) OFF = Low limit alarm ON = High limit alarm	ON/OFF	OFF
xAL 7	Not used	Per input range	10%
xAL 8	Not used	Per input range	5%
xAL 9	Alarm limit for sequence-based alarms (applies only if AL0 = 4 to 6 in output mode, 7) <i>Note: Linked parameter. Changing this parameter will as well change xAL7</i>	0 - 100%	8%
xAL A	Hysteresis for alarm setback for sequence-based alarms (applies only if AL0 = 4 to 6 in output mode or 7) <i>Note: Linked parameter. Changing this parameter will as well change xAL8</i>	0 - 100%	4%
xAL B	Sound alarm (SRD2, TRI2 and OPT1 only)	ON/OFF	OFF

Note: xAL represents the index of the actual used alarm 1 - n according to the X2 product.

6.10 Output cycle mode

This may be used as a valve cycle to activate an output that has been inactive for an extended period of time. On the other hand, it may as well be used to deactivate an output that was active for a certain time.

6.10.1 General function

In cycle mode, the output will activate after a defined timeout period (AL5) for a set period of time (run time, AL7). After the run time has expired, the output will stay off for the timeout period and will activate again after it has expired and so forth.

Normally an output is activated which is inactive during the timeout time. This can be inverted by AL 6. An output is then deactivated, which is active for a long time.

6.10.2 Activate cycle mode while output is OFF or ON

The behavior may be reversed using AL6. If set to ON, timeout will start when the output is on and the output will deactivate during the run time defined in AL7. The timeout period will restart, should the output activate in direct mode or deactivate in reverse mode during the defined the timeout period.

This function can be set with AL8 to be only active during certain operation modes. It can therefore be used either as valve cycle or as humidity or mould control feature. Important is to keep AL4 = ON if the function should be active in OFF or disabled mode.

Truth table for cycle activation in interlock mode (AL3 = ON)

	AL4 = OFF	AL4 = ON
AL8 = 0	Only active in on mode	Always active
AL8 = 1	Only active in on mode	Only active in on mode
AL8 = 2	Not active	Only active in off mode
AL8 = 3	Not active	Only active in disabled mode
AL8 = 4	Not active	Only active in off or disabled mode

6.10.3 Parameter reference for output cycle mode

Parameter	Description	Range	Default
xAL 0	Select alarm type: 8 = Timeout or cycle mode for outputs.	0 - 8	0
xAL 1	Select fan, digital or analog output if xAL 0 = 4, 5, 6, 8 0 = Interlock or alarm not active 1..x = selected output	0 - 8	0
xAL 2	Select type of device for timeout detection if xAL0 = 8 0 = Operation mode, Active if operation mode is OFF. (Revert using AL6) 1 = fan, Active if fan is off 2 = digital output 3 = analog output	0 - 10	0
xAL 3	Alarm or interlock mode OFF = Alarm mode active: Icon and the words ALA# on the small digits indicating active alarm will appear on display, reset option in xAL4 applies. ON = Interlock mode: Outputs revert to normal operation when alarm condition is no longer present, Icon and text indicating active alarm will not appear.	ON/OFF	OFF
xAL 4	Automatic reset or acknowledge to reset (only if AL3 = OFF) OFF = Alarm condition resets automatically. ON = Alarm condition must be reset manually.	ON/OFF	OFF
	Select if interlock is active in OFF mode (only if AL3 = ON) OFF = Interlock is not active while controller is in off mode or disabled ON = Interlock is active independent of controller state		
xAL 5	Timeout period: time while the output is off. This time will be reset if the output activates.	00:00s...252h	00:00
xAL 6	Direct or reversed action (applies only if AL0 = 4, 5, 6, 8) OFF = Direct: Output off, cycle detection active ON = Reverse: Output on, cycle detection active	ON/OFF	OFF
xAL 7	Run time in cycle mode. (Applies only if AL0 = 8) Interlock or alarm will be activated for the run time specified here. <i>Note: linked parameter. Changing this parameter will change as well xAL9</i>	00:00s...252h MM:SS...HHH	00:00 MM:SS or h
xAL 8	Activation in cycle mode. (Applies only if AL0 = 8) 0 = function is active independent of operation mode 1 = function is active only in ON mode 2 = function is active only in OFF mode 3 = function is active only in disabled mode 4 = function is active only in OFF and disabled mode. <i>Note: linked parameter. Changing this parameter will change as well xALA</i>	0 - 4	0
xAL B	Sound alarm (SRD2, TRI2 and OPT1 only)	ON/OFF	OFF

Note: xAL represents the index of the actual used alarm 1 - n according to the X2 product.

7 Control loop configuration

7.1 Manipulation of the setpoint

7.1.1 Unoccupied mode setpoints

Unoccupied mode may be enabled using UP06. In unoccupied mode alternative setpoints may be used. Unoccupied mode may be activated with FU02 or manually on a key pad or through communication.

There are two possibilities to change the setpoint in unoccupied mode: Shift it by L07 or switch to the minimum setpoint limit in heating mode and maximum setpoint limit in cooling by setting xL27 to ON. Unoccupied mode may be disabled by setting UP06 to OFF.

7.1.2 Setpoint compensation

The setpoint compensation is typically used to compensate the set point due to a change in outside temperature. Enable summer or winter set point compensation for this control loop with L05. Both setpoint shift or setpoint setback are possible. They are described in more detail under auxiliary function 4FU.

7.1.3 Display of setpoint value:

Depending on the configuration of the controller there are various set points that might be active. If the control loop is in heating only or cooling only setup, this means if only one sequence is enabled, the acting setpoint is shown. If both sequences are enabled, the controller is in 4-pipe mode. In this case the set point shown is the setpoint which lies between the acting heating and cooling setpoints. The distance between the displayed setpoint and the acting setpoint is called dead zone (xL08). In unoccupied mode, the acting setpoint is shown in all cases.

7.1.4 Set point limits heat/cool or summer/winter

There are different setpoint limits available. One set when the control loop is in heating mode and one when it is in cooling mode. For 4-pipe systems it is useful to control the setpoint limits by a summer – winter flag instead of heating – cooling mode. To have set point limits follow summer winter instead of heating/cooling, enable xL28. Set point limits now follow the setting of UP24 (summer / winter mode).

7.2 Controlling the setpoint through another loop (cascade control)

A primary loop calculates an output based on its settings and a measured input signal. This output is then used to determine the setpoint of the secondary loop. The output value of the primary loop is a value between 0 and 100%. The secondary loop will then take this value and span it proportionally between its lower and higher setpoint limits to determine its setpoint.

Cascade control is activated on the secondary loop through setting xL06 to 2-4. The primary loop is always the loop with the lower index. For example, if loop 2 is the secondary loop and sets 2L06 = 4, the loop 1 will be the primary loop.

The sequence of the primary loop to be cascaded may be selected by choosing xL06 = 2 for reverse only, xL06 = 3 for direct only and xL06 = 4 for both options.

7.2.1 Manual override of cascade

The set point of cascaded secondary control loops may be manually overridden if not disabled with UP02. Such an override will not reset automatically. To reset back to auto mode, change the set point again while in manual mode and it will return to auto.

7.2.2 Controlling the setpoint through a potentiometer or input

Select the input to be used with xL06. The selected input must be set to 0 - 100% or be in potentiometer mode. The value of the input will then be spanned between the upper and lower setpoint limits of the active mode (heating, cooling or summer, winter). A value of 0% of the input will then result in the set point to match the lower limit and a value of 100% results in the setpoint being identical to the upper limit. The values in between are adjusted proportionally.

7.3 Heating / cooling – reverse / direct sequence.

Each control loop has its own direct / reverse status. On top of this, the controller has its own status that is independent of each loop. The controller status may be influenced by the function FU3, manually or through communication.

It may be confusing to see a different heat/cool symbol in idle mode compare to the one shown on loop 1 or loop 2. This would then be the case if the heat/cool status of the controller is not connected to a loop or FU3. In this case it should be connected to loop 1. This may be achieved in FU3.

Activation of reverse / direct sequence for each loop

The active sequence for each loop may be determined either by demand or it may be tied to the heat / cool mode of the controller.

Note: Only when a control loop has both its sequences assigned to an output can it switch between heating and cooling mode on demand.

7.3.1 Switch over delay in on demand mode

If heat / cool sequence is determined on demand, the mode will change once there is demand for the time defined with L25. A delay makes sense to prevent frequent switching between cooling and heating in case there is an involuntary overshoot. For certain applications it may make sense to set the delay to 0.

7.4 Fault detection of a control loop

It is possible to determine if a control loop does not reach its setpoint. To do this a maximum setpoint deviation may be defined with L26. Using the alarm feature with AL0 = 2, the control loop may be supervised. If the setpoint can not be reached within the limit defined in L26 and the time defined in the alarm definition, an alarm may be generated.

7.5 PI control sequence

7.5.1 Activating control loops

Control loops and sequences are activated by assigning outputs to them in the output configuration section.

7.5.2 Dead zone between heating and cooling

XDZ defines the dead zone between heating and cooling setpoint. This prevents a change from heating to cooling during a control overshwing. Another tool to prevent this is a delay before this switch is taking place.

7.5.3 Setpoint dead band

In V1.7, xL10 has been reconfigured from an offset to a setpoint deadband. This means that the setpoint becomes a range. For example, with a humidifier, if xL10 is set to 5% and the humidity setpoint is 50%, the setpoint is met between 45% and 55%. In this area, proportional output will be 0, and the integral will not change.

This results in less wear on equipment and energy savings.

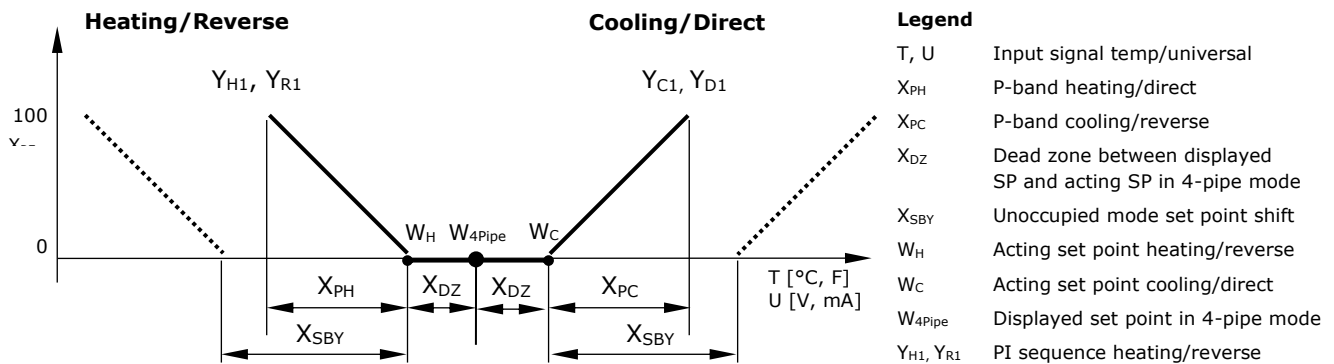

7.5.4 Proportional control (Xp = P-band)

The proportional control function calculates the output based on the difference between setpoint and input. The proportional band (P-band) defines the difference between setpoint and input required to produce a 100% output. For example: a heating control sequence and a 2.0°C (4.0°F) P-band value will produce a 10V output (100%) when the input temperature is 2.0°C (4.0°F) below setpoint. This is the working range of the proportional control sequence. With 1°C (2°F) below setpoint, the output will be 5V (50%).

Setting the proportional band to 0 disables proportional control. This is required for very fast control systems such as fan control through air pressure transmitters.

Formula: $Y_p = e/X_p$, whereas $X_p = 1/K_p$ and $e = \text{error}$

7.5.5 Integral control

Proportional control is in most cases a very stable control mode. The flaw of proportional control alone, however, is that the setpoint is normally not reached. As the measured value gets closer to the setpoint, the output reduces until it reaches a point, a fraction above or below the setpoint, where the output equals the load. To reach the setpoint and achieve a higher level in comfort, the integral function should be activated.

The sum of the errors (esum) is multiplied with the integral gain parameter Ki and a constant of 0.0235, Ti is used to reduce the parameter Ki further for slower integral action.

$$\text{Formula: } Y_i = K_i/T_i * 0.0235 * \text{esum}$$

Setting the integral gain to 0 disables integral and differential control.

7.5.6 Define the PI controller through reset time Tn

With V1.5 we created a different way to define the integral using the more commonly used integral reset time Tn.

The Reset Time is defined as the time required to obtain the same output as for the proportional action by using an integral action only.

$$T_i = 0: T_n = \frac{1}{K_i * X_p} \text{ or to calculate with parameters set with } T_i \neq 0: T_n = T_i * \frac{1084}{K_i * X_p}$$

$$\text{Formula to calculate } K_i \text{ from } T_n: \frac{K_i}{T_i} = \frac{1084}{T_n * X_p}$$

$$\text{Formula for PI with } T_n: Y = \frac{e}{X_p} + \frac{\text{esum}}{T_n * X_p}$$

Ki = Integral parameter

Ti = Interval in seconds for integral calculation, if set to 0, Tn calculation will be used.

Xp = Pband in unit of input

Tn = Integral reset time in seconds

e = error (direct sequence (cooling): current value - setpoint or reverse sequence (heating): setpoint - current value

The reset time Tn instead of Ki can be defined by setting Ti to 0. In order for the reset time to work, a proportional band Xp is essential. If both Xp and Ti are set to 0, the controller will set Xp to its maximum value instead for calculation purpose.

Recommended Values

	Heating Air		Heating Radiant		Cooling		Humidifying	Dehumidifying	Pressure
	5°C	10°F	6°C	12°F	4°C	8°F	10%	10%	80% FS
P-band	5°C	10°F	6°C	12°F	4°C	8°F	10%	10%	80% FS
Measuring interval (Ti)	1	1	2	4	1	1	2	2	1
Integral gain (Ki)	0.4	0.2	0.1	0.1	0.8	0.4	0.1	0.1	1.0
Reset time (Tn) Ti = 0	9 min		60 min		6 min		36 min	36 min	14 s

7.5.7 Switching digital outputs based on PI sequence:

Digital outputs and fans can now directly correspond to PI levels. In order to achieve this, select the required loop, sequence and switching level with the output parameter of the corresponding digital output or fan.

7.6 Digital control sequence

7.6.1 Selecting stage action

Cumulative stage action (L16=0) is typically used in electric heat applications, and single stage action (L16=1) in fan speed applications. Digital stage action (L16=2) is especially useful in electric heat applications to generate three steps with just two outputs. For example: Step 1=100W, step 2=200W, step 3=300W.

	Cumulative	Single	Digital
Stage 1	Q1	Q1	Q1
Stage 2	Q1+Q2	Q2	Q2
Stage 3			Q1+Q2

7.6.2 Hysteresis

Switching hysteresis (L21) is the difference between switching on and switching off. A small hysteresis will increase the number of switching cycles and thus the wear on associated equipment.

7.6.3 Time delays

With minimum running time delay (L22) cumulative stages will not switch on simultaneously. With a sudden demand or initial startup, power stage 2 will not start earlier than 10 seconds (default value) after stage 1 has been initiated.

Likewise, after a stage is switched off, it will remain switched off until L23 is expired. This is to avoid rapid switching.

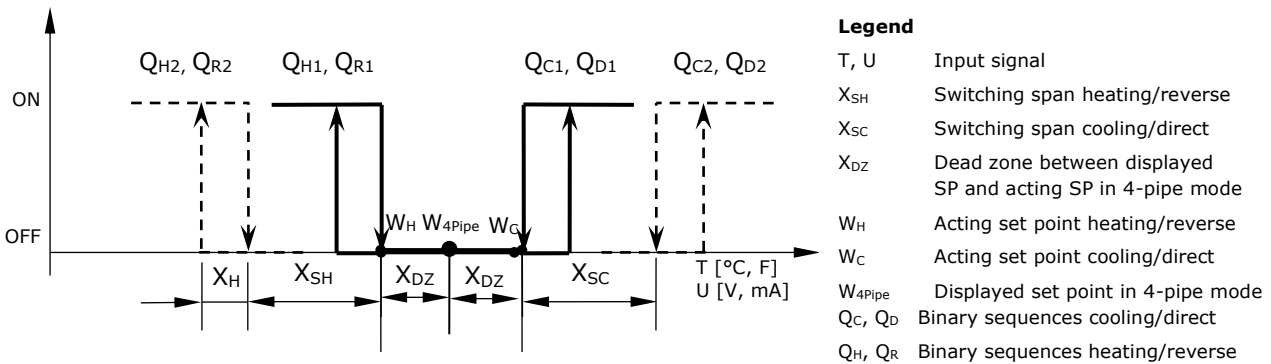

7.7 Parameter reference for control loops

Parameter	Description	Range	Default
xL 00	Select loop control input (0= loop disabled): input according hardware, 1 = UI1, 2 = UI2, etc.	0 - 12	1
xL 01	Minimum set point limit heating or winter mode	per input range	0%
xL 02	Maximum set point limit heating or winter mode	per input range	100%
xL 03	Minimum set point limit cooling or summer mode	per input range	0%
xL 04	Maximum set point limit cooling or summer mode	per input range	100%
xL 05	Enable set point compensation. Setpoint compensation is further described in auxiliary function 4FU. 0= disabled 1= winter compensation 2= summer compensation 3= winter and summer	0 - 3	0
xL 06	Select loop setpoint (0= normal): 1 = combine setpoint with previous control loop 2 = cascade with reverse sequence of primary loop 3 = cascade with direct sequence primary loop 4 = cascade with both reverse and direct sequence of primary loop 5 = UI1 (percentage of input value is spanned between set point limits) 6 = UI2 (percentage of input value is spanned between set point limits) 7 = UI3 (percentage of input value is spanned between set point limits) 8 = UI4 (percentage of input value is spanned between set point limits) 9 = UI5 (percentage of input value is spanned between set point limits) 10 = UI6 (percentage of input value is spanned between set point limits) <i>Note: for input based setpoints: input must be set to 0 - 100% or in potentiometer mode.</i>	0 - 10	0

Parameter	Description	Range	Default
xL 07	X _{SBY} : Unoccupied mode setpoint shift If xL27 = OFF, the occupied setpoint is shifted by the value set with this parameter. The heating set point is reduced and the cooling set point is increased.	Per input range	5%
xL 08	X _{DZ} : Heat/Cool-Dead zone between heating and cooling set point in 4-pipe mode In 4-pipe mode, if both heating and cooling sequences of a loop are enabled, the center setpoint is shown on the display.	Per input range	2%
xL 09	Choose alarm or interlock to disable control loop. If any of the selected alarms is active, the control loop will be disabled. All connected outputs will be off or 0%. ▽▽▽▽▽▽▽▽ Alarm: 1 2 3 4 5 6 7 8	Triangle shown = alarm selected	▽▽▽▽▽▽▽▽
xL 10	X _{DB} : Setpoint dead band: While within this range the control loop has reached its target.	per input range	0%
xL 11	X _{PH} : P-band heating: Proportional band for heating (reverse) sequence	per input range	2%
xL 12	X _{PC} : P-band cooling: Proportional band for cooling (direct) sequence	per input range	2%
xL 13	xL15 ≠ 0: Integral gain heating (0.1 steps): low= slow reaction, high= fast reaction xL15 = 0: Integral reset time heating T _n	0 – 25.5 00:00 – 15:10h	0.0
xL 14	xL15 ≠ 0: Integral gain cooling (0.1 steps) xL15 = 0: Integral reset time cooling T _n	0 – 25.5 00:00 – 15:10h	0.0
xL 15	Measuring interval integral (seconds): low= fast reaction, high value= slow reaction Set to 0 to change xL13/xL14 to integral reset time T _n	0 – 255	1 sec.
xL 16	Action of stages: 0= cumulative: stage 1 stays on when 2 comes on 1= single: stage 1 turns off when 2 comes on 2= digital: stage 1 only, stage 2 only, then stage 1 plus 2	0 – 2	0
xL 17	X _{OBH} : Offset for heating/reverse binary sequences. Offset shifts the acting set point away from the displayed or saved set point	per input	0%
xL 18	X _{OBC} : Offset for cooling/direct binary sequences. Offset shifts the acting set point away from the displayed or saved set point	per input	0%
xL 19	X _{SH} : Switching span heating. Switching span is the difference between set point and measured value required for the next binary stage to activate.	per input	2%
xL 20	X _{SC} : Switching span cooling. Switching span is the difference between set point and measured value required for the next binary stage to activate.	per input	2%
xL 21	X _H : Switching hysteresis	per input	0.5%
xL 22	Switching delay min running time for binary stage	00:00s...15:10h MM:SS...HH:MM	00:10 MM:SS
xL 23	Switching delay min stopping time for binary stage	00:00s...15:10h MM:SS...HH:MM	00:10 MM:SS
xL 24	Activation of reverse/direct (heat/cool) sequence OFF= activates based on demand ON = follows heat/cool state of controller: Set manually or by auxiliary function (3FU)	ON/OFF	OFF
xL 25	Delay for heat/cool changeover in case above parameter is OFF. This delay prevents frequent switching of sequences.	00:00s...15:10h MM:SS...HH:MM	05:00 MM:SS
xL 26	Max allowed set point deviation (will generate an alarm if enabled in alarm parameters), Disabled if set to 0.	per input	0.0
xL 27	Fixed set point in unoccupied mode OFF = In unoccupied mode, set point is shifted according to xL07 ON = In unoccupied mode use minimum set point limit as set point in heating mode or maximum set point limit in cooling mode	ON/OFF	OFF
xL 28	Set point limits selection based on summer winter OFF = Set point limits follow heat – cool setting of control loop ON = Set point limits follow summer – winter flag (UP 24)	ON/OFF	OFF

Note: xL represents the index of the actual used control loop 1 - n according to the X2 product.

8 Analog outputs

8.1 Analog output signal types

Depending on the type of device used, the outputs may be fixed to 0–10 VDC-type signal or for the universal types they can be selected with jumpers to 0/4–20mA or 0/2–10VDC.

8.2 Available outputs for different X2 products

The number of outputs available for a device is defined in its product datasheet. Here is an overview over the X2 product range:

	TCX2-40863	TCX2-23343	TCX2-24273	TCV2-433.443	TCI2	SxC2	TRI2	SRD2-411	SRD2-212
A01	Universal	VDC	VDC	VDC	Universal	Universal	VDC	VDC	Universal
A02	Universal	VDC	VDC	VDC	Universal	Universal	VDC	VDC	Universal
A03	Universal	VDC	VDC	VDC				VDC	

8.3 Signal range

The standard signal range can be selected with parameter A02. Custom ranges can be created by setting minimum and maximum signal limits.

The signal range can be chosen depending on heating / cooling sequence of an assigned control loop. This may come in handy for VAV systems, where in heating mode a low volume or air is supplied while in cooling mode the air is used for cooling.

- For **VAV Function** individual minimum and maximum may be assigned for cooling and heating. In VAV applications maximum cooling output matches the maximum air volume the VAV box is set to deliver. As demand for airflow in cooling mode decreases, airflow dwindles until it reaches minimum cooling output (A05). minimum will be based on the airflow needed at design and is typically 10% to 15% of maximum cooling airflow. this minimum is reached the system is in dead-band – heating nor cooling. Minimum airflow in heating mode is with A03. As the system moves into heating mode, heating airflow increases until it reaches the maximum heating output (A04), typically 30 to 50% of maximum cooling airflow.

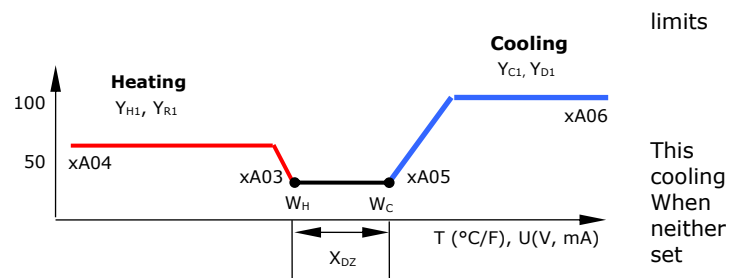

Note: A control loop, special function, digital control or PI-control sequence is not active until it is assigned to an output.

8.3.1 Control for 6-way valve or airside dampers

- For control of 6-way-valves or air side dampers: One sequence may be reversed while the other operates normal. This will set the off position at the minimum value of the last active sequence:
- For example, if xA03 is set to 45% and xA04 to 20%, xA05 to 75% and xA06 to 100%. At full heating the output will generate 2 V and with full cooling 10 V while will generate 4.5 or 7.5V in Off mode (depending on active sequence) or if no demand.
- Alarms will still work normal (0V, 10V or intermediate according to xA15). The intermediate alarm will ignore min/max or 2-10 V signal limitations.

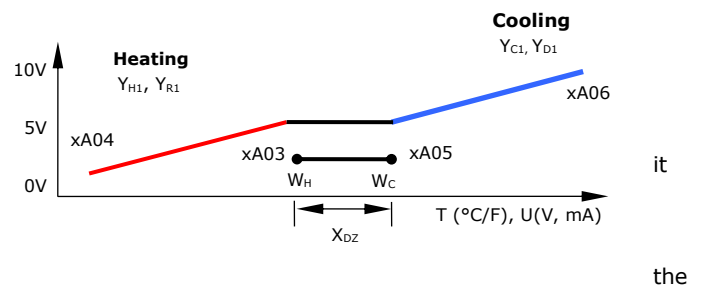

8.4 Alarm or interlock selection

Every output may be activated or deactivated based on a series of alarms or interlocks. Alarms specify fault conditions of the control application; interlocks may be used to offer additional control options. Alarms operate as well when the controller is in off mode. Interlocks can be selected to be active in off mode or not.

To activate the output while an alarm is pending, select the alarm in A07. To deactivate the output with the alarm pending, select it in A08. The output will be switched off, if alarms are active in both A07 and A08.

In case the same alarm is selected in xA07 and xA08, the output will be set to the level set in A15 in case the alarm activates.

8.4.1 Specific output level for alarms or interlocks

Selecting the same alarm for both 0% and 100% output will activate a special level that can be specified in A15.

8.5 Manual positioning and I/O mode

With manual positioning (xA00=6), the output may be controlled by time schedule or directly through a setpoint in 0.5% steps. Setting xA01 to 0 will disable access to manual positioning through the operation terminal. The output will then only be controlled by time schedule or through communication.

With manual positioning, the position of the output will be written as a setpoint to the internal non-volatile-memory (EEPROM). The non-volatile memory of the controller has a limited number of write cycles (~100000). If the output is used as an I/O module, a remote controller writes to this output frequently and will therefore shorten the lifespan of the controller. For this application two I/O mode settings are introduced with V1.7. With these settings, the position of the output is only written to volatile memory (RAM). This memory has no write limitation.

When xA 00 = 6 Manual positioning:

xA01 = 0: Allow time schedule only

xA01 = 1: Allow manual positioning and time schedules

xA01 = 2: I/O module mode

xA01 = 3: I/O module mode and manual positioning

8.6 Assigning an output to a control loop

With parameter A00 choose the control loop the output should respond to. Only those control loops are available that are in the X2 product specs on the functional scope table. A maximum of 4 control loops is available. Assigning an output to a control loop, activates this loop.

8.6.1 Selecting the sequence

How the output should react to the loop is selected with A01. These are the options:

0= Respond to heating/reverse PI-sequence only

1= Respond to cooling/direct PI sequence only

2= Respond to both heating/reverse and cooling/direct sequences (4 pipe)

3= 100% on if loop in heating mode: Reversing valve mode

4= 100% on if loop in cooling mode: Reversing valve mode

5= Transmit set point: (Specify signal range with A09, A10, A11)

6 = Heating/reverse step mode

7 = Cooling/direct step mode

8 = Heating and Cooling step mode

8.6.2 Adjusting the range of the PI-sequence

The part of a PI-sequence an output covers may be adjusted using parameters A12 and A14. This is useful to span one PI sequence over multiple outputs. For example, by assigning 0 - 50% of the PI sequence to AO1 and 50 - 100% to AO2. This could be used for multiple valves that are connected to these outputs with valve 1 controlling half the load and valve 2 the second half, with both valves being assigned to the same control loop.

Note: For normal operation with one analog output per PI sequence A12 must be 0% and A14 to 100%. Else not the entire PI range may be applied to this output.

8.6.3 Transmitting the setpoint of a control loop

The setpoint of a control loop may be converted to an analog signal by setting A01 to 5. First the input assigned to the control loop needs to be selected with A09. The signal range must be configured using A10 and A11, with A10 carrying the minimum and A11 the maximum range limits. For example, for a temperature range of 15°C to 35°C with a 10VDC output signal each degree would be indicated with a 0.5V step increase on the signal, with 0V corresponding to 15°C and 10V to 35 °C.

This signal could then be sent to a secondary system that monitors the status of that control loop. By configuring interlocks or alarms and adjusting signal ranges, different modes may be transmitted to the secondary system.

For example the signal range could be limited to 2..8 VDC. 0V would then mean that the system is OFF, 10V would mean that an alarm condition is pending, 2..8 VDC would mean that the system is in normal operation.

8.6.4 Maximum of loop 1 and loop 2

An analog output may be set to react on the maximum output value of two control loops by setting A00 = 8.

A combination of indirect and reverse sequences may be chosen. Applications for this function are CO2 and moisture control for ventilation and dehumidification. The sequences of loop 1 and loop2 may be chosen with A01

0 = Loop 1: Heating, Reverse

Loop 2: Heating, Reverse

1 = Loop 1: Cooling, Direct

Loop 2: Heating, Reverse

2 = Loop 1: Heating and Cooling

Loop 2: Heating, Reverse

3 = Loop 1: Heating, Reverse

Loop 2: Cooling, Direct

4 = Loop 1: Cooling, Direct

Loop 2: Cooling, Direct

5 = Loop 1: Heating and Cooling

Loop 2: Cooling, Direct

8.6.5 Step mode

In step mode, the analog output function checks if any binary outputs in PI mode are assigned to the same loop and sequence. It will then adjust its limits of the PI sequence based on those of the active binary output. Below is an example based on stage 1 on DO1 and stage 2 on DO2 in heating and cooling mode. The DO must be controlled by PI signal with d11 = ON and the stage number must be defined with xd03 for this to work. In case no DO is assigned to the sequence and loop, the range of the AO will be adjusted to 0 - 100%.

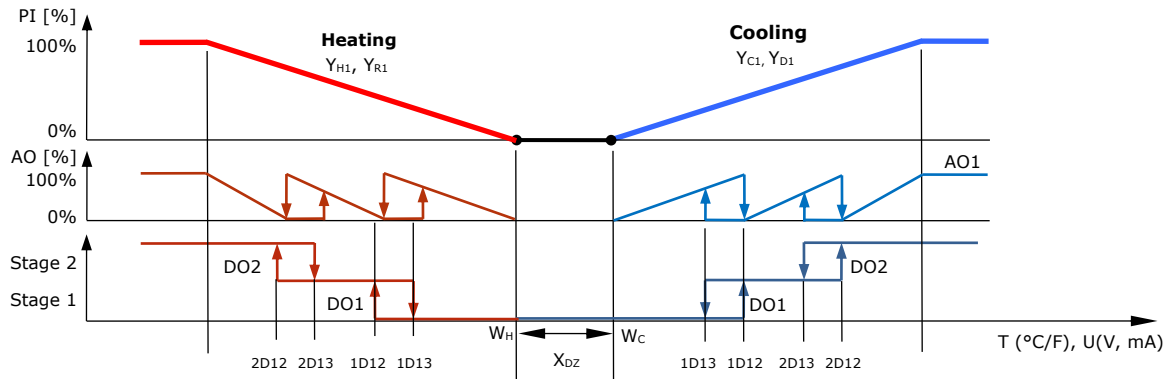

8.7 Special functions of the analog output

8.7.1 Dehumidification

To activate the dehumidification function for 4-pipe systems, the following setup is required:

1. Loop 1 has to be the temperature loop, assign the temperature input to loop 1.
2. Loop 2 has to control relative humidity
3. On the cooling output, activate special functions (A00 = 5) and Dehumidification (A01 = 00).

The analog cooling output will now activate cooling either if temperature or humidity is too high. In case humidity is too high the room will get cooler, which will trigger the heating mode. Cool air contains less humidity per m³ than warm air. Therefore, when the air gets heated up again, the humidity will be reduced. It is important for this system to work that the cooling coil is mounted in front of the heating coil.

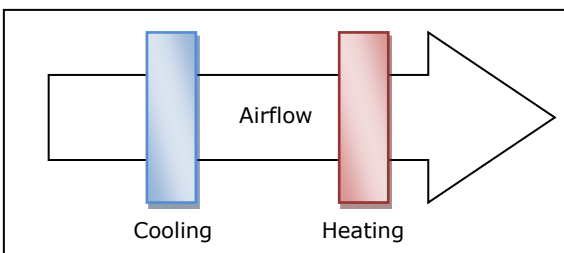

8.7.2 Free heating/free cooling settings

The free heating/cooling principle is handled under special functions FU5. Here just a quick summary:

With FU5 the outdoor and indoor climatic condition is compared and if possible, the outdoor and return air damper are both modulated in order to use outside air to reduce heating or cooling costs.

If A01 is set the 1, the output will function as an outdoor damper. Which means for fresh air the output will modulate to 100%. If A01 is set to 2, it will work as a return air damper and it thus works inverse to the outdoor damper. For fresh air, it will go to 0%.

8.8 Use as transmitter or signal converter for inputs

The analog output may be configured as signal converter and transmitter:

Measured and calculated input values (A00=7) may be transmitted on the analog output.

Select the input whose value is to be transmitted with A09. Then set the lower and upper limits of the analog signal with A10 and A11. It is important to first configure and choose the input before setting the limits. As the limits depend on the type and signal range of the assigned input.

8.9 Analog outputs for fan modules:

An analog output may be assigned to a fan module by selecting xF09 = ON.

In this case the fan module has a higher priority than the analog output settings. The signal type and min/max values as well as the alarm functions still apply. Parameters A12-A14 are used to define the output value of the three fan speeds with A12 for the low speed, A13 medium and A14 the high speed.

8.10 Override mode

Override mode can be enabled to temporarily manually control an output for commissioning or service purposes. When override mode is enabled, the configurations defined with xA00 to xA01, as well as the alarm and interlock configurations, are ignored. The output enters manual mode and can be set to a desired output level. The output level set in this way is defined by the manual setpoint of the corresponding output.

This setting may be activated in BACnet by setting the analog output state object "AO-XX-ST" to "4 = Override".

8.11 Parameter reference for analog outputs

Parameter	Description	Range	Default
xA 00	Select control loop or special function: 0 = OFF 1 = Loop 1 2 = Loop 2 3 = Loop 3 4 = Loop 4 5 = Special functions (Dehumidification, Free heating/cooling, etc.) 6 = Manual positioning, time schedules, I/O module mode (0-100%) 7 = Transmit value of an input (Specify signal with xA09-xA11) 8 = Max of loop 1 and loop 2	0 - 8	1
xA 01	When xA00=1 - 4 configure output: 0= Heating/reverse 1= Cooling/direct 2= Heating and cooling (4 pipe) 3= 100% on if loop in heating mode: Reversing valve mode 4= 100% on if loop in cooling mode: Reversing valve mode 5= Transmit set point: (Specify signal with xA09, xA10 and xA11) 6 = Heating/reverse step mode 7 = Cooling/direct step mode 8 = Heating and Cooling step mode	0 - 5	0
	When xA00=5, select function: 0 = Dehumidification: Max of loop 1 cooling and loop 2 dehumidifying 1 = Economizer: Outdoor damper actuator. See 5FU for more details. 2 = Economizer: Return air damper actuator. See 5FU for more details.		
	When xA00 = 6 Manual positioning, time schedules, I/O module mode 0 = Allow time schedule only 1 = Allow manual positioning and time schedules 2 = I/O Module mode 3 = I/O Module mode and manual positioning		
	When xA00 = 8 Maximum of output of loop 1 and loop 2 0 = Loop 1: Heating, Reverse Loop 2: Heating, Reverse 1 = Loop 1: Cooling, Direct Loop 2: Heating, Reverse 2 = Loop 1: Heating and Cooling Loop 2: Heating, Reverse 3 = Loop 1: Heating, Reverse Loop 2: Cooling, Direct 4 = Loop 1: Cooling, Direct Loop 2: Cooling, Direct 5 = Loop 1: Heating and Cooling Loop 2: Cooling, Direct		
xA 02	Type of output signal: OFF= 0-10V, 0-20mA, ON= 2-10V, 4-20mA	ON/OFF	OFF
xA 03	Minimum limitation of output signal default and in loop heating mode	0 - 100%	0%
xA 04	Maximum limitation of output signal default and in loop heating mode	0 - 100%	100%
xA 05	Minimum limitation of output signal in loop cooling mode	0 - 100%	0%
xA 06	Maximum limitation of output signal in loop cooling mode	0 - 100%	100%
xA 07	Choose alarm to set output to 100% (output 0% on conflicting alarms)	Triangle shown = alarm selected	1 2 3 4 5 6 7 8 ▽▽▽▽▽▽▽▽
xA 08	Choose alarm to set output to 0%. (output 0% on conflicting alarms) <i>Note: setting the same alarm on xA07 and xA08 will set output to the level defined in xA15 if this alarm activates.</i>	Triangle shown = alarm selected	1 2 3 4 5 6 7 8 ▽▽▽▽▽▽▽▽
xA 09	If xA01 = 5, feedback of setpoint, specify Input used in control loop here: input according hardware, 1 = UI1, 2 = UI2, etc.	0 - 15	0
xA 10	Minimum transmit value of inputs or set points. <i>Note: linked parameter: changing this parameter will change as well xA12</i>	per input range	0%
xA 11	Maximum transmit value of inputs or set points <i>Note: linked parameter: changing this parameter will change as well xA14</i>	per input range	100%
xA 12	In loop sequence mode: Span PI sequence: lower limit of PI sequence. Loop sequence mode is entered when the analog output is assigned to a loop in A00 and a sequence with A01. With this setting, the sequence may now be spanned over different outputs. For example AO1 0 - 50% and AO2 50 - 100%. <i>Note: linked parameter: changing this parameter will change as well xA10</i>	0 - 100%	0%
xA 14	In loop sequence mode: Span PI sequence: upper limit of PI sequence. See xA12 for explanation. <i>Note: linked parameter: changing this parameter will change as well xA11</i>	0 - 100%	100%
xA 15	In case the same alarm is selected in xA07 and xA08, the output will be set to the here defined level, in case the alarm activates. With V1.5 R2 This setting does not follow the span defined with min/max settings. Instead, it will generate a fixe voltage from a 0 - 10 V or 0 - 20 mA signal. E.g.: 50% = 5 VDC or 10 mA.	0 - 100%	50%
xA 16	Activate override mode The output is put into manual mode, settings from xA00, xA01, xA07, xA08 are ignored	ON/OFF	OFF

Note: xA represents the index of the actual used analog output 1 - n according to the X2 product.

8.12 Parameter reference analog output in fan mode

Parameter	Description	Range	Default
xA 12	If analog output is in fan mode: set output level for fan speed 1 (Low) <i>Note: linked parameter: changing this parameter will change as well xA10</i>	0 - 100%	0%
xA 13	If analog output is in fan mode: set output level for fan speed 2 (Medium)	0 - 100%	50%
xA 14	If analog output is in fan mode: set output level for fan speed 3 (High) <i>Note: linked parameter: changing this parameter will change as well xA11</i>	0 - 100%	100%

9 Digital outputs

The digital outputs may be used to control fans, floating point actuators, single stages, or PWM outputs. In case an output is defined for more than one function the following priority applies in assigning physical outputs:

Priority	Physical outputs	DO1	DO2	DO3	DO4	DO5	DO6
1	2 fan outputs up to 3 speeds each:	FAN 1			FAN 2		
		speed 1	speed 2	speed 3	speed 1	speed 2	speed 3
		1FA 0 ≥ 1	1FA 0 ≥ 2	1FA 0 = 3	2FA 0 ≥ 1	2FA 0 ≥ 2	2FA 0 = 3
2	3 floating point outputs:	FO1		FO2		FO2	
		open	close	open	close	open	close
3	6 digital or PWM outputs:	DO1	DO2	DO3	DO4	DO5	DO6

Note: FAN1 or FAN2 modules may as well be assigned to analog outputs. FAN1 controls AO1 and FAN2 controls AO2. In this case DO1 – DO3 for FAN1 and DO4 – DO6 for FAN2 will be free for other uses.

9.1 Available digital outputs for different X2 products

The number of outputs available for a device is defined in its product datasheet. Here is an overview over the X2 range:

		TCX2-40863	TCX2-23343	TCX2-24273	TCX2-14050	TCV2-433.343
FAN		FAN1 FAN2	FAN1	FAN1	FAN1	FAN1
DO1	FO1	Relays NO	Relays NO	Relays NO	Relays NO	Relays 24 V
DO2		Relays NO	Relays NO	Relays NO	Relays NO	Relays 24 V
DO3	FO2	Relays NO	Relays NO	Relays NO	Relays NO	Relays 24 V
DO4		Relays NO	Relays NO	Relays NO	Relays NO	SSR 24 V
DO5	FO3	Relays NO	-	TRIAC 5VA	Relays NO	SSR (ACT)
DO6		Relays NO	-	TRIAC 5VA	-	SSR (ACT)
DO7		-	-	Relays NO	-	SSR 24 V

FOx = 3-point floating point outputs (always 2 binary outputs)

		TCI2	TRI2	SxC2	SRD2-220/411	SRD2-212
FAN		FAN1	FAN1 FAN2	FAN1	FAN1	FAN1
DO1	FO1	Relays NO	Relays NO	Relays SPDT	Relays SPDT	-
DO2		Relays NO	Relays NO	-	-	-

9.1.1 Digital output types

Type	Properties
Relays NO	A relays contact normally open. It means without power this contact is open (not connected). If the relays is energized, the contact will close (connect).
Relays SPDT	A relays with a Single Pole Double Through contact. It means it has a normally open and a normally closed contact, with a common contact between them.
TRIAC	A TRIAC is a semiconductor that controls the energy flow. It has no moving parts and is therefore useful for large switching cycles such as on pulsing outputs. The downside is that it can only switch AC voltage and tends to heat up when switching larger loads.



Important Note

On all current switching devices, load must be observed. Do not exceed maximum limits under any circumstance!

10 Fan configuration

Most X2 products contain one fan module. The TCX2-40863 is the only one with 2 modules.

A fan module may be used to control fans with binary stages or analog steps, it may be controlled by PI- or digital sequences. It may as well be put into lead-lag mode.

10.1 Selecting the number of fan speeds

The fan module is enabled by defining the number of fan speeds used with F00. The range is between 0 and 3. With 0, the fan module is disabled.

If the fan module is assigned to binary stages, the digital outputs are controlled by the fan module. FAN1 controls DO1 up to DO3 and FAN2 DO4 up to DO6.

10.2 Fan module for analog outputs

The fan module may as well be assigned to an analog output. In this case FAN1 controls AO1 and FAN2 AO2. This can be useful for EC (electronically commutated) type fans or if external switching modules are used instead of digital outputs.

To use an analog output instead of digital outputs, set F09 to ON and then specify output switching levels. The output switching levels define the analog output according each fan speed. The levels are set in the corresponding analog output settings (1A12 to 1A14, AO1) for Fan1 and (2A12 to 2A14, AO2) for Fan2.

10.3 Alarm or interlock selection

Every fan module may be activated or deactivated based on a series of alarms or interlocks. Alarms specify fault conditions of the control application; interlocks may be used to offer additional control options. Alarms operate as well when the controller is in off mode. Interlocks can be selected to be active in off mode or not.

To activate the fan module while an alarm is pending, the alarm may be specified in A07. The fan will always run in its highest speed if activated with an alarm or interlock.

To deactivate the output with a pending alarm, it may be set in A08. The fan will be switched off, if alarms are active in both A07 and A08.

10.4 Manual positioning and I/O mode

With manual positioning (F01=6), the fan may be controlled by time schedule or manually. Setting F02 to 0 will disable manual access through the operation terminal. The fan speed will then only be controlled by time schedule or through communication.

With manual positioning, the position of the fan will be written as a setpoint to the internal non-volatile-memory (EEPROM). The non-volatile memory of the controller has a limited number of write cycles (~100000). If the output is used as an I/O module, a remote controller writes to this output frequently and will therefore shorten the lifespan of the controller. For this application two I/O mode settings are introduced with V1.7. With these settings, the position of the fan is only written to volatile memory (RAM). This memory has no write limitation.

When xF 01 = 6 Manual positioning:

xF02 = 0: Allow time schedule only

xF02 = 1: Allow manual positioning and time schedules

xF02 = 2: I/O module mode

xF02 = 3: I/O module mode and manual positioning

10.5 Startup and switch off delay

During the startup or the switch off delay of a fan module all other control outputs assigned to control loop 1 for fan module 1 or control loop 2 for fan module 2, will be deactivated.

The idea is to give the fan extra time to run to prevent overheated electrical heating batteries for example or develop pressure before launching humidifiers.

10.6 Assigning the fan module to a control loop

The fan module is assigned to a control loop by setting F01 to 01 for loop 1, 02 for loop 2 and so forth. Only those control loops are available that are in the X2 product specs on the functional scope table. A maximum of 4 control loops is available. Assigning an output to a control loop, activates this loop. Assigning it to a control loop that is not existent will render the output unresponsive.

Once the output is assigned to a control loop, the sequence it responds to must be defined. This is done with F02. The fan may activate only during heating (F02 = 0) or cooling mode (F02 = 1) or both of them (F02 = 2). Additionally, there is the option to active only the low fan speed, if there is demand by only the heating (F02 = 3), cooling sequence (F02 = 4) or by both of them (F02 = 5). With demand-based loop control, the controller will check if a PI output assigned to its particular control loop and sequence is active. If so, the fan will run in low speed.

10.6.1 Binary or PI-sequence

Per default the fan speeds are selected by a binary sequence as defined under the control loop. If a fan speed is switched it depends on setpoint, switching span and hysteresis (see control loop for details).

By setting F10 = ON, the fan speeds are instead controlled by the PI sequence. With F11 the switching limit to activate fan speed 1 is set, with F12 fan speed 2 and with fan speed 3. Once the PI sequence has reached the herein defines threshold the fan will increase its speed. To reduce the speed the PI sequence needs to fall below the fan speed limit minus the fan speed hysteresis defined in F14.

	Fan off	Fan speed 1	Fan speed 2	Fan speed 3
PI increasing	-	PI > F11	PI > F12	PI > F13
PI decreasing	PI < (F11 - F14)	PI < (F12 - F14)	PI < (F13-F14)	-

10.6.2 Behavior when setpoint is satisfied

Should the fan keep running when there is no more demand or should it switch off? This may be defined with parameter F03. These are its options:

- 0 = Fan off when no demand
- 1 = Lowest fan speed on when occupied. Fan switches off when not occupied.
- 2 = Lowest fan speed on in cooling mode. Fan switches off in heating mode.
- 3 = Lowest fan speed on when operation mode on, occupied and unoccupied (mold protection)

10.6.3 Maximum of loop 1 and loop 2

A fan module may be set to react on the maximum output value of two control loops. A combination of indirect and reverse sequences may be chosen. Applications for this function are CO2 and moisture control for ventilation and dehumidification. The sequences of loop 1 and loop2 may be chosen with F02

- 0 = Loop 1: Heating, Reverse Loop 2: Heating, Reverse
- 1 = Loop 1: Cooling, Direct Loop 2: Heating, Reverse
- 2 = Loop 1: Heating and Cooling Loop 2: Heating, Reverse
- 3 = Loop 1: Heating, Reverse Loop 2: Cooling, Direct
- 4 = Loop 1: Cooling, Direct Loop 2: Cooling, Direct
- 5 = Loop 1: Heating and Cooling Loop 2: Cooling, Direct

10.6.4 Manual override of fan speeds

Automatic fan speeds can be overridden by keypad if manual mode is enabled (UP02 = ON). If fan can be manually disabled F08 need to be set to ON.

10.7 Activating the fan on state of controller

The fan may be run in its highest speed when the controller is in ON mode occupied or unoccupied (F01 = 5) or when it is in ON and Occupied mode (F01 = 7). As with assigning the fan to a loop, as well in this mode it can be defined if the fan should respond only in heating (F02 = 0) or only in cooling mode (F02 = 1) or independent of these modes (F02 = 2).

Should the fan only activate if there is demand on any control loop and any output of the controller there is the option to choose F02 = 3 for controller in heating mode, F02 = 4 when controller in cooling mode and F02 = 5 if any demand on the controller independent of mode.

10.8 Fan only operation

This parameter allows the controller to operate in fan-only mode. When F18 = ON, the advanced user can set the controller to fan-only mode. In this mode, only the fan will operate according to its heat/cool settings and the mechanical heating or cooling outputs will be disabled. When changing heating and cooling via the operator panel, fan-only mode is indicated by a fan icon being displayed together with the heating or cooling icon.

10.9 Override mode

Override mode can be enabled to temporarily manually control an output for commissioning or service purposes. When override mode is enabled, the configurations defined with xF00 to xF02, as well as the alarm and interlock configurations, are ignored. The output enters manual mode and can be set to a desired output level. The output level set in this way is defined by the manual setpoint of the corresponding output.

This setting may be activated in BACnet by setting the analog output state object "FAN-XX-ST" to "4 = Override".

10.10 Parameter reference for fan mode

Parameter	Description	Range	Default
xF 00	Select the number of fan speeds	0 - 3	0
xF 01	Selection of control loop for fan 0 = Fan output not active 1 = Loop 1 2 = Loop 2 3 = Loop 3 4 = Loop 4 5 = Operation mode (on, when operation mode is on, occupied and unoccupied) 6 = Manual positioning, time schedule controlled, I/O module mode 7 = Occupied mode (on if occupied, off if unoccupied) 8 = Max of loop 1 and loop 2 9 = Lead-Lag for digital outputs: DO1 → DO2 → DO3	0 - 9	1
xF 02	Fan outputs select active sequence of control loop if F01=1-4 or select active state of controller if F01=5,7: 0 = if xF01 = 1-4, 5,7: Heating, Reverse 1 = if xF01 = 1-4, 5,7: Cooling, Direct 2 = if xF01 = 1-4, 5,7: Heating and Cooling (4 pipe system) 3 = if xF01 = 1-4, 5,7: Demand based on Heating, Reverse 4 = if xF01 = 1-4, 5,7: Demand based on Cooling, Direct 5 = if xF01 = 1-4, 5,7: Demand based on Heating and Cooling	0 - 5	2
	When F01 = 6: Manual positioning, time schedules, I/O module mode 0 = Allow time schedule only 1 = Allow manual positioning and time schedules 2 = I/O module mode 3 = I/O module mode and manual positioning		
	When F01 = 8: Maximum of output of loop 1 and loop 2 0 = Loop 1: Heating, Reverse Loop 2: Heating, Reverse 1 = Loop 1: Cooling, Direct Loop 2: Heating, Reverse 2 = Loop 1: Heating and Cooling Loop 2: Heating, Reverse 3 = Loop 1: Heating, Reverse Loop 2: Cooling, Direct 4 = Loop 1: Cooling, Direct Loop 2: Cooling, Direct 5 = Loop 1: Heating and Cooling Loop 2: Cooling, Direct		
xF 03	Fan behavior when setpoint is satisfied if F01 = 1-8: 0 = Fan off when no demand 1 = Lowest fan speed on when occupied. Fan switches off when not occupied. 2 = Lowest fan speed on in cooling mode. Fan switches off in heating mode. 3 = Lowest fan speed on when operation mode on, occupied and unoccupied (mold protection)	0 - 4	0
xF 04	Startup delay: Delay before starting fan. Other control outputs connected to the same control loop are disabled during startup delay.	00:00s...15:10h MM:SS...HH:MM	00:00s MM:SS
xF 05	Switch off delay: If the fan should extend its run time after the control valves are closed. Set the time to extend fan run time after control outputs switch off.	00:00s...15:10h MM:SS...HH:MM	00:00s MM:SS
xF 06	Choose alarms to set fan to 100%. In case of conflicting alarms, the fan will be switched off. See section alarms for further details.	Triangle shown = alarm selected	1 2 3 4 5 6 7 8 ▽▽▽▽▽▽▽▽
xF 07	Choose alarms to switch off fan. See section alarms for further details.	Triangle shown = alarm selected	1 2 3 4 5 6 7 8 ▽▽▽▽▽▽▽▽
xF 08	Manual fan switch off mode When F01 = 1-4 or 6: Manual switch off of fan OFF = Fan may not be switched off manually while assigned to control loop ON = Fan can be set to off manually while assigned to control loop	ON/OFF	OFF
xF 09	Choose output DO or AO: OFF = DO, ON = AO FAN1: OFF = DO1-DO3, ON = AO1 FAN2: OFF = DO4-DO6, ON = AO2 <i>Note: In case F09 = ON, analog output signal must be defined with analog output parameters 1A02 to 1A06 for fan1 or 2A02 to 2A06 for fan2.</i>	ON/OFF	OFF
xF 10	Use PI sequence as input for fan (not binary sequence)	ON/OFF	OFF
xF 11	Limit for fan speed 1 if F10 = ON <i>Note: Linked parameter: Changing this value, will as well change F15.</i>	0 - 100%	20%
xF 12	Limit for fan speed 2 if F10 = ON <i>Note: Linked parameter: Changing this value, will as well change F16.</i>	0 - 100%	50%
xF 13	Limit for fan speed 3 if F10 = ON <i>Note: Linked parameter: Changing this value, will as well change F17.</i>	0 - 100%	80%
xF 14	Hysteresis for fan speeds if F10 = ON	0 - 100%	15%
xF 18	Enable fan only mode. When set to ON, the controller can operate in fan only mode, if OFF, fan only mode will be deactivated when selected.	ON/OFF	OFF
xF 19	Activate override mode The output is put into override mode, settings from xF00 - xF07 are ignored	ON/OFF	OFF

Note: xF represents the index of the actual used fan 1 - n according to the X2 product.

11 Lead-lag configuration

The fan module may be used to rotate a group of digital outputs based on their run time. This is commonly used with pumps or where multiple devices control one function.

11.1 The function of lead – lag module

The lead lag module allows up to 3 stages to run one or two at the time. By using the A07 of the lead-lag module, additional stages may be activated for example if demand is not met. With A08, the module may be deactivated.

The lead-lag module may be activated by setting F01 = 9. The number of lead – lag stages is defined in F00.

The number of simultaneous active outputs is set with F02 (1 or 2).

Following options are possible:

	F00	F02
Lead – Lag	2	1
Lead – Lag – Lag	3	1
Lead – Lead – Lag	3	2

11.1.1 Assigning digital outputs

Only digital outputs may be assigned to the lead lag module. The digital outputs must be assigned to the lead – lag module by setting their parameter d01 to 10. In d02 the lead – lag module and its function may be selected. Option 4...7 only apply if 2 fan modules are present.

There is a fixed assignment for control loops to fan modules for demand-based applications. Control Loop 1 is assigned to Fan module 1 and Control Loop 2 is assigned to Fan module 2.

These are the options for d02:

- 0 = module 1 not demand based
- 1 = module 1, if demand on loop 1, heating only
- 2 = module 1, if demand on loop 1, cooling only
- 3 = module 1, if demand on loop 1 heating & cooling
- 4 = module 2 not demand based
- 5 = module 2, if demand on loop 2, heating only
- 6 = module 2, if demand on loop 2, cooling only
- 7 = module 2, if demand on loop 2 heating & cooling

11.1.2 Setting the running time for each stage

In F15 the running time of each stage must be set. The time format is defined with F03 for minutes, hours or days. After a stage was active for the time defined in F15, the stage will be deactivated and the next stage will be activated.

11.1.3 Allowing manual control

Manual control is allowed with F08. This gives the user the option to select the current active stage manually through the operating terminal. While manual control is active, automatic rotation is suspended. Automatic rotation may only be resumed by interaction with the operation terminal.

11.1.4 Status verification

The current active output may now be seen in F16, the current running time since the last switch is visible with F17. These settings and times may be changed through access to parameters.

11.2 Demand based operation

The digital outputs assigned to the lead lag module can now have lag and disable interlocks assigned to them.

To do this a maximum delay alarm may be assigned to an interlock, this interlock may then be enabled under F06. For each active interlock an additional stage will get activated.

11.2.1 Supervision of each output

A disable alarm may be assigned to a digital output configured as a lead – lag stage. If this alarm disables the output, the lead – lag module will instead activate the standby output or if non defined, the next available stage.

Stages may be chosen in the digital output section with d03: These are the options:

- 0 = standby
- 1 = stage 1
- 2 = stage 2
- 3 = stage 3

11.3 Switching between stages

After the run time defined in F15 has expired or an assigned output was disabled by alarm, the next available stage will be activated. Note individual delays may be assigned to each output. For the lead lag stages it is done in the following process:

For one active stage:

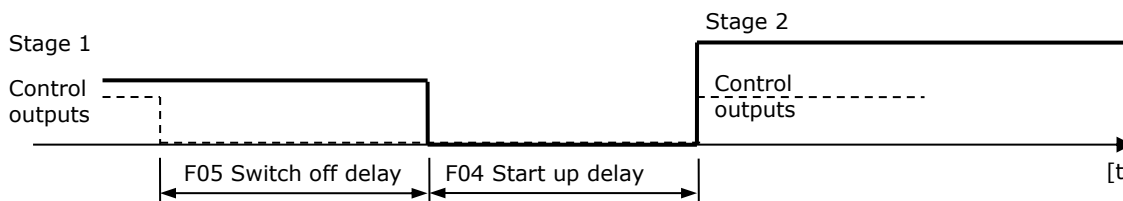

For two active stages:

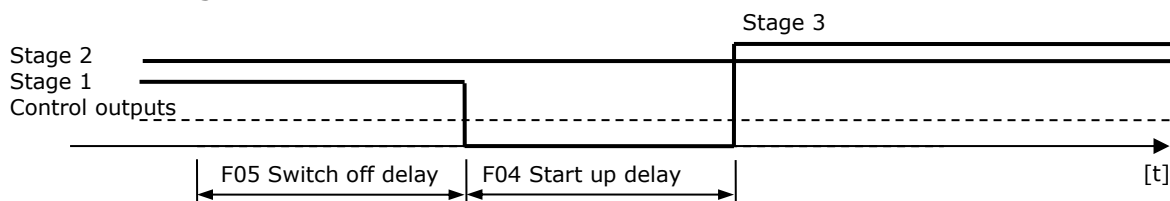

11.4 Parameter reference for lead-lag mode

Parameter	Description	Range	Default
xF 00	Total number of lead/lag stages	0 - 3	0
xF 01	Selection of control loop for fan 9 = Lead-lag configuration: OUT1 → OUT2 → OUT3	0 - 9	1
xF 02	In lead-lag mode: Define number of simultaneous active outputs. If set to 0 or 1, then only one output will be active at the same time, if set to 2 than 2 outputs will be active at each time. For this to work at least 3 outputs must be activated.	0 - 5	2
xF 03	In lead-lag mode (F01 = 9): Step length of F15 0 = Steps defined in F15 are counted in minutes 1 = Steps defined in F15 are counted in hours 2 = Steps defined in F15 are counted in days (24h) PS: set to 0 for testing purpose.	0 - 3	0
xF 04	Startup delay: Delay before starting new stage. For single lead only: Other outputs assigned to same control loop are disabled during delay.	00:00s...15:10h MM:SS...HH:MM	00:00s MM:SS
xF 05	Switch off delay: Delay while switching off old stage. For single lead only: Other outputs assigned to same control loop are disabled during delay.	00:00s...15:10h MM:SS...HH:MM	00:00s MM:SS
xF 06	Choose interlocks to activate an additional stage to the lead lag module. For each active interlock one more stage will be added (up to 3 additional). ▽▽▽▽▽▽▽▽ Alarm: 1 2 3 4 5 6 7 8	Triangle shown = alarm selected	▽▽▽▽▽▽▽▽
xF 07	Choose alarms to switch off lead lag module. See section alarms for further details. ▽▽▽▽▽▽▽▽ Alarm: 1 2 3 4 5 6 7 8	Triangle shown = alarm selected	▽▽▽▽▽▽▽▽
xF 08	Manual control of output rotation When F01 = 9: lead-lag mode OFF = Lead-lag stages may not be controlled manually ON = Lead-lag stages can be controlled manually <i>Note: setting an output to manual while in lead lag mode, will interrupt output rotation indefinite until set back to auto mode.</i>	ON/OFF	OFF
xF 15	In lead lag mode (F01 = 9): Running time in minute, hours or days. (Set with F03). While in auto mode, the controller will switch to the next output after this time has expired.	0 - 255	50
xF 16	If F01 = 9: Current active output (1-3)	0 - 3	-
xF 17	If F01 = 9: Run time in minute, hours or days (set with F03) for current of output since last switch.	0 - 255	-
xF 18	Not relevant in this mode	ON/OFF	OFF

Note: xF represents the index of the actual used fan 1 - n according to the X2 product.

Note: other Fxx parameters not listed may be ignored and do not apply to the module in lead lag mode.

12 Floating output (d00 = ON)

12.1 3-point floating actuators functional description

With 3-point floating we understand an actuator that has an opening and a closing contact. While the opening contact is activated the actuator opens and when the closing contact is active it closes. If no contact is active, it keeps the current position. Both contacts must not be active at the same time. The actuator should have a more or less constant running time between fully open and fully closed. A 3-point floating output therefore always combines 2 digital outputs. This function is typically used for 3-point valves.

12.1.1 Activating 3-point mode

To activate 3-point floating mode, d00 of an odd numbered digital output needs to be set to ON. This output and the following even numbered one will now be combined in a floating output. The odd one is the closing and the even one the opening output. As the output may frequently open and close TRIAC outputs are preferred for 3-point control.

12.1.2 Running time and position synchronization

The running time specifies the time required for the actuator to run from fully closed to fully open or vice versa. The controller counts the seconds the actuator was running in open or close direction and from this calculates the position. Ideally the actuator has a constant running time. In most cases after a while the actual position might be somewhat different to the actual position. Therefore, whenever the actuator reaches a fully open or fully closed position, the run time will be extended by 100% in that direction (opening if fully opened and closing if fully closed). This way a clear position is then guaranteed. After a power failure the actuator will first move into a fully closed position and then open again.

Thus, the actuator must be able to be energized when in its end position for the duration of a full cycle.

12.1.3 Switching difference required for floating output to move

In order to reduce the number of switching cycles for the actuator and to extend the lifetime of the controller and actuator it is possible to define after what kind of change the actuator should move. This change is calculated in the number of seconds the actuator will be running for the next position compare to the current position it is in. This way the actuator won't run for just a one or 2 second step.

12.1.4 Output based on controller state

The floating output may as well be controlled by the state of the controller. To do this d01 must be set to 7. The behavior can then be set in d02. These are the options:

- 0= ON if controller operation state is ON
- 1= ON while demand on any output
- 2= ON while controller in heating mode
- 3= ON while controller in cooling mode
- 4= ON if controller state is occupied, OFF if unoccupied

D03 controls the influence of the OFF, disabled and occupied state on the output. The controller is in disabled mode if it was deactivated by the auxiliary function FU1.

- 0 = output is off, when operation mode is off
- 1 = output is off, when operation mode is disabled
- 2 = operation mode has no effect on output

12.2 Alarm or interlock selection

Every output may be activated or deactivated based on a series of alarms or interlocks. Alarms specify fault conditions of the control application; interlocks may be used to offer additional control options. Alarms operate as well when the controller is in off mode. Interlocks can be selected to be active in off mode or not.

To activate the output while an alarm is pending, select the alarm in d07. To deactivate the output with the alarm pending, select it in d08. The output will be switched off, if alarms are active in both d07 and d08.

12.3 Manual positioning and I/O mode

With manual positioning (d01=6), the output may be controlled by time schedule or directly through a setpoint in 0.5% steps. Setting d02 to 0 will disable access to manual positioning through the operation terminal. The output will then only be controlled by time schedule or through communication.

With manual positioning, the position of the output will be written as a setpoint to the internal non-volatile-memory (EEPROM). The non-volatile memory of the controller has a limited number of write cycles (~100000). If the output is used as an I/O module, a remote controller writes to this output frequently and will therefore shorten the lifespan of the controller. For this application two I/O mode settings are introduced with V1.7. With these settings, the position of the output is only written to volatile memory (RAM). This memory has no write limitation.

- When xd 01 = 6 Manual positioning:
- xd02 = 0: Allow time schedule only
- xd02 = 1: Allow manual positioning and time schedules
- xd02 = 2: I/O module mode
- xd02 = 3: I/O module mode and manual positioning

12.4 Assigning an output to a control loop

With parameter d01 choose the control loop the output should respond to. Only those control loops are available that are in the X2 product specs on the functional scope table. A maximum of 4 control loops is available. Assigning an output to a control loop, activates this loop.

12.4.1 Selecting the sequence

How the output should react to the loop is selected with d02. These are the options:

- 0= Respond to heating/reverse PI-sequence only
- 1= Respond to cooling/direct PI sequence only
- 2= Respond to both heating/reverse and cooling/direct sequences (4 pipe)
- 3= 100% on if loop in heating mode: Reversing valve mode
- 4= 100% on if loop in cooling mode: Reversing valve mode
- 5 =Output in 3 – point mode using on/off sequences

12.4.2 Heating and cooling in on/off mode

This function is for a 3-point actuator configured using two on / off sequences of a control loop. The reverse sequence opens the actuator while the direct sequence closes the actuator. This function may be used for VAV actuator either in CAV mode or as secondary loop for a cascaded VAV loop.

While there is not sufficient pressure, the actuator opens, if there is too much pressure the loop changes direction and the actuator closes. The hysteresis and the dead zone settings reduces the wear on the actuator and limits rapid movements.

The position of the actuator always starts at 0% after a power failure and will not limit its opening or closing capacity. It is therefore required that the actuator has a switch off function at its end point in place as the output will remain active until the pressure demand has been satisfied.

12.4.3 Maximum of loop 1 and loop 2

A floating output may be set to react on the maximum output value of two control loops by setting d01 = 8.

A combination of indirect and reverse sequences may be chosen. Applications for this function are CO2 and moisture control for ventilation and dehumidification. The sequences of loop 1 and loop2 may be chosen with d02

- | | |
|---------------------------------|--------------------------|
| 0 = Loop 1: Heating, Reverse | Loop 2: Heating, Reverse |
| 1 = Loop 1: Cooling, Direct | Loop 2: Heating, Reverse |
| 2 = Loop 1: Heating and Cooling | Loop 2: Heating, Reverse |
| 3 = Loop 1: Heating, Reverse | Loop 2: Cooling, Direct |
| 4 = Loop 1: Cooling, Direct | Loop 2: Cooling, Direct |
| 5 = Loop 1: Heating and Cooling | Loop 2: Cooling, Direct |

12.5 Special functions of the floating output

12.5.1 Dehumidification

To activated the dehumidification function for 4-pipe systems, the following setup is required:

1. Loop 1 has to be the temperature loop, assign the temperature input to loop 1.
2. Loop 2 has to control relative humidity
3. On the cooling output, activate special functions (A00 = 5) and Dehumidification (A01 = 00).

The floating cooling output will now activate cooling either if temperature or humidity is too high. In case humidity is too high the room will get cooler, which will trigger the heating mode. Cool air contains less humidity per m3 than warm air. Therefore, when the air gets heated up again, the humidity will be reduced. It is important for this system to work that the cooling coil is mounted in front of the heating coil.

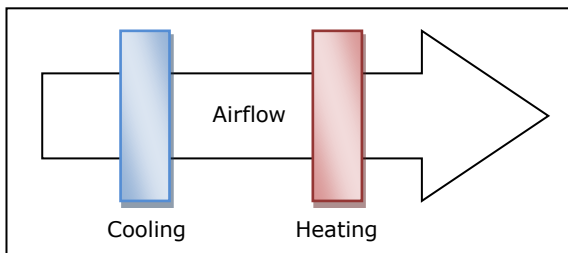

12.5.2 Free heating/free cooling settings

The free heating/cooling principle is handled under special functions FU5. Here just a quick summary:

With FU5 the outdoor and indoor climatic condition is compared and if possible, the outdoor and return air damper are both modulated in order to use outside air to reduce heating or cooling costs.

If AO1 is set the 1, the output will function as an outdoor damper. Which means for fresh air the output will modulate to 100%. If AO1 is set to 2, it will work as a return air damper and it thus works inverse to the outdoor damper. For fresh air, it will go to 0%.

12.5.3 Use as proportional function for inputs

The position of a floating output may be based on an input value. The input is selected with d02. Two limits define the proportional range: A minimum (d14) and a maximum limit (d15). Depending on these limits the output may be controlled through a sinking or a rising input signal.

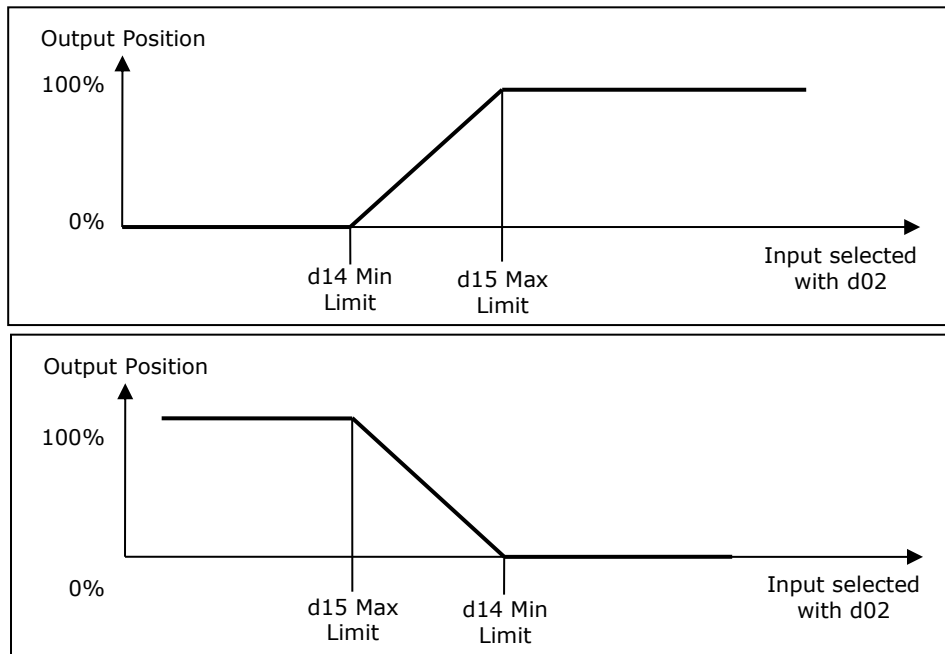

12.6 Override mode

Override mode can be enabled to temporarily manually control an output for commissioning or service purposes. When override mode is enabled, the configurations defined with xd00 to xd03, as well as the alarm and interlock configurations (xd07/xd08), are ignored. The output enters manual mode and can be set to a desired output level. The output level set in this way is defined by the manual setpoint of the corresponding output.

This setting may be activated in BACnet by setting the analog output state object "DO-XX-ST" to "4 = Override".

12.7 Parameter reference for floating output configuration

Parameter	Description	Range	Default
xd 00	Enable digital or floating point output xd00 = OFF: DO1, DO2 are two digital/PWM outputs xd00 = ON : DO1, DO2 is one floating point output (DO1 open, DO2 close)	ON/OFF	OFF
xd 01	Select control loop or special function 0 = Not active 1 = Loop 1 2 = Loop 2 3 = Loop 3 4 = Loop 4 5= Special functions (Dehumidification, Economizer, etc.) 6= Manual positioning, time schedules, I/O module mode 7= Controller state functions 8 = Max of loop 1 and loop 2 9 = Proportional function: Output assigned to an input	0 - 9	0
xd 02	When xd01=1-5 configure output: 0= Heating/reverse 1= Cooling/direct 2= Heating and cooling (2 pipe) 3= 100% on if loop in heating mode: Reversing valve mode 4= 100% on if loop in cooling mode: Reversing valve mode 5= Heating and cooling on/off mode	0 - 15	0
	When xd01=5, select function: 0 = Dehumidification: Max of loop 1 cooling and loop 2 dehumidifying sequence. 1 = Economizer: Outdoor air damper actuator. See 5FU for more details. 2 = Economizer: Return air damper actuator. See 5FU for more details.		
	When xd01 = 6 Manual positioning, time schedules, I/O module mode 0 = Allow time schedule only 1 = Allow manual positioning and time schedules 2 = I/O module mode 3 = I/O module mode and manual positioning		

Parameter	Description	Range	Default
	<p>When xd01=7 select state functions: 0= ON if controller operation state is ON 1= ON while demand on any output 2= ON while controller in heating mode 3= ON while controller in cooling mode 4= ON if controller state is occupied, OFF if unoccupied</p> <p>When xd01 = 8 Maximum of output of loop 1 and loop 2 0 = Loop 1: Heating, Reverse Loop 2: Heating, Reverse 1 = Loop 1: Cooling, Direct Loop 2: Heating, Reverse 2 = Loop 1: Heating and Cooling Loop 2: Heating, Reverse 3 = Loop 1: Heating, Reverse Loop 2: Cooling, Direct 4 = Loop 1: Cooling, Direct Loop 2: Cooling, Direct 5 = Loop 1: Heating and Cooling Loop 2: Cooling, Direct</p> <p>When xd01 = 9: Select input for proportional function. Minimum and maximum limits are defined with xd14 and xd15: Input according hardware: 0 = disabled, 1 = UI1, 2 = UI2, etc.</p>		
xd 03	<p>When xd01=6, 7 and 9: Select reaction on on/off/disable operation mode 0 = output is off, when operation mode is off 1 = output is off, when operation mode is disabled 2 = operation mode has no effect on output</p>	0 - 6	0
xd 04	Running time (Time for actuator to run from fully open to fully close)	00:00s...15:10h MM:SS...HH:MM	00:00s MM:SS
xd 05	Switching difference for floating point signal: to reduce the switching frequency of the actuator. The actuator will only move if the running time to move the actuator from its current position to the target position is larger than this parameter.	00:00s...15:10h MM:SS...HH:MM	00:05s MM:SS
xd 07	Choose alarm to set output to 100% (output 0% on conflicting alarms)	Triangle shown = alarm selected	1 2 3 4 5 6 7 8 ▽▽▽▽▽▽▽▽
xd 08	Choose alarm to set output to 0% (output 0% on conflicting alarms)	Triangle shown = alarm selected	1 2 3 4 5 6 7 8 ▽▽▽▽▽▽▽▽
xd 10	Intermediate alarm: In case the same alarm is selected in xd07 and xd08, the output will be set to the here defined level, in case the alarm activates.	0 - 100%	0%
xd 14	<p>Proportional function based on input (xd01 = 9): Minimum limit: If xd15 > xd14: when input value is above this limit, output starts to increase. If xd15 < xd14: when input value is below this limit, output starts to increase. <i>Note: Linked parameter: changing this value, will change as well xd12</i></p>	0 - 100%	0%
xd 15	<p>Proportional function based on input (xd01 = 9): Maximum limit: If xd15 > xd14: when input value is above this limit, output is at 100%. If xd15 < xd14: when input value is below this limit, output is at 100%. <i>Note: Linked parameter: changing this value, will change as well xd13</i></p>	0 - 100%	0%
xd 16	<p>Activate override mode The output is put into manual mode, settings from xd00 - xd02 and xd 07, xd 08 are ignored</p>	ON/OFF	OFF

Note: xd represents the index of the actual used output 1 - n according to the X2 product.

13 Digital output (d00 = OFF)

13.1 Activating digital mode

To activate digital mode, d00 needs to be set to OFF AND the output may not be part already assigned to a floating or fan output (See chapter configuration of digital outputs). In digital mode, the output may be configured to switch on and off a single device such as a valve with a spring return actuator or a heating element. By defining a PWM cycle time, the output may as well be pulsed using Pulse Width Modulation (PWM). See chapter 13.13, page 54 for related settings. For digital mode to be active the cycle time set in d06 MUST be 0. Anything but 0 will put the output in PWM mode.

13.2 Switching delays

The switch off delay d04 defines the time the output signal needs to be off, before output switches off.

The switch on delay d05 defines the time the output signal needs to be on, before output switches on.

Note: with state functions, all control outputs are disabled during switch ON delay

13.3 Alarm or interlock selection

Every output may be activated or deactivated based on a series of alarms or interlocks. Alarms specify fault conditions of the control application; interlocks may be used to offer additional control options. Alarms operate as well when the controller is in off mode. Interlocks can be selected to be active in off mode or not.

To activate the output while an alarm is pending, select the alarm in d07. To deactivate the output with the alarm pending, select it in d08. With V1.5 it is now possible to set a PWM or floating output to an intermediate position by setting the same alarm in d07 and d08. While this alarm is active, the output will then go to the position defined with d10.

The output will be switched off, if different alarms are active in d07 and d08.

13.4 Manual positioning and I/O mode

With manual positioning (d01=6), the output may be controlled by time schedule or directly through a setpoint in ON/OFF for digital mode or 0.5% steps for PWM mode. Setting d02 to 0 will disable access to manual positioning through the operation terminal. The output will then only be controlled by time schedule or through communication.

With manual positioning, the position of the output will be written as a setpoint to the internal non-volatile-memory (EEPROM). The non-volatile memory of the controller has a limited number of write cycles (~100000). If the output is used as an I/O module, a remote controller writes to this output frequently and will therefore shorten the lifespan of the controller. For this application two I/O mode settings are introduced with V1.7. With these settings, the position of the output is only written to volatile memory (RAM). This memory has no write limitation.

When xd 01 = 6 Manual positioning:

xd02 = 0: Allow time schedule only

xd02 = 1: Allow manual positioning and time schedules

xd02 = 2: I/O module mode

xd02 = 3: I/O module mode and manual positioning

13.5 Switching based on controller state

The digital output may as well be controlled by the state of the controller. To do this d01 must be set to 7. The behaviour can then be set in d03. These are the options:

0= ON if controller operation state is ON

1= ON while demand on any output

2= ON while controller in heating mode

3= ON while controller in cooling mode

4= ON if controller state is occupied, OFF if unoccupied

Parameter d03 controls the influence of the OFF, disabled and occupied state on the output. The controller is in disabled mode if it was deactivated by the auxiliary function FU1. One application for this function is the light switching option. An input may be assigned to an output and control it. The output may be part of a zone controller that controls the climate of a zone. The climate control may be deactivated, but the light should still work while the zone is occupied. Once the zone is unoccupied, the light should switch off. The occupancy may be used to disable the controller. Therefore, the setup would work to use do3 = 1.

0 = output is off, when operation mode is off

1 = output is off, when operation mode is disabled

2 = operation mode has no effect on output

13.6 Assigning an output to a control loop

With parameter d01 choose the control loop the output should respond to. Only those control loops are available that are in the X2 product specs on the functional scope table. A maximum of 4 control loops is available. Assigning an output to a control loop, activates this loop.

13.6.1 Selecting the sequence

How the output should react to the loop is selected with A01. These are the options:

- 0 = Respond to heating/reverse PI-sequence only
- 1 = Respond to cooling/direct PI sequence only
- 2 = Respond to both heating/reverse and cooling/direct sequences (4 pipe)
- 3 = On if loop in heating mode: Reversing valve mode
- 4 = On if loop in cooling mode: Reversing valve mode
- 5 = On while demand in heating or cooling mode

13.6.2 Maximum of loop 1 and loop 2

A floating output may be set to react on the maximum output value of two control loops by setting d01 = 8.

A combination of indirect and reverse sequences may be chosen. Applications for this function are CO2 and moisture control for ventilation and dehumidification. The sequences of loop 1 and loop2 may be chosen with d02

- | | |
|---------------------------------|--------------------------|
| 0 = Loop 1: Heating, Reverse | Loop 2: Heating, Reverse |
| 1 = Loop 1: Cooling, Direct | Loop 2: Heating, Reverse |
| 2 = Loop 1: Heating and Cooling | Loop 2: Heating, Reverse |
| 3 = Loop 1: Heating, Reverse | Loop 2: Cooling, Direct |
| 4 = Loop 1: Cooling, Direct | Loop 2: Cooling, Direct |
| 5 = Loop 1: Heating and Cooling | Loop 2: Cooling, Direct |

Note: this selection only works in binary sequence mode (d11 = OFF).

13.6.3 Switch digital output based on PI-sequence

This feature allows a direct response to PI output value if the output is assigned to a control loop (d01 = 1..4). The output may be switched based on PI sequence rather than binary sequence of control loop.

To do this set d11 = ON and define switching limits with d12 and d13. D12 is the activating limit and d13 is the deactivating limit. If d12 > d13, the output will activate if the PI value is > d13 and it will deactivate if PI is below d13. If d13 > d12, the output will activate if PI value is < d12 and deactivate if > d13.

Note: d11 does not apply for maximum of loop 1 and loop 2 configurations (d01 = 8). To switch a maximum condition based on PI, configure the output as normal loop 1 output and assign an interlock to a control loop sequence and activate the output with that interlock.

13.7 Special functions of the binary output

13.7.1 Dehumidification

To activated the dehumidification function for 4-pipe systems, the following setup is required:

1. Loop 1 has to be the temperature loop, assign the temperature input to loop 1.
2. Loop 2 has to control relative humidity
3. On the cooling output, activate special functions (A00 = 5) and Dehumidification (A01 = 00).

The floating cooling output will now activate cooling either if temperature or humidity is too high. In case humidity is too high the room will get cooler, which will trigger the heating mode. Cool air contains less humidity per m3 than warm air. Therefore, when the air gets heated up again, the humidity will be reduced. It is important for this system to work that the cooling coil is mounted in front of the heating coil.

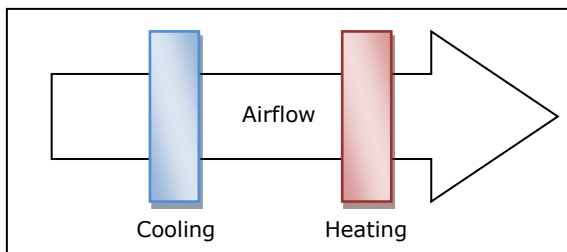

13.7.2 Free heating/free cooling settings

The free heating/cooling principle is handled under special functions FU5. Here just a quick summary:

With FU5 the outdoor and indoor climatic condition is compared and if possible, the outdoor and return air damper are both modulated in order to use outside air to reduce heating or cooling costs.

If A01 is set the 1, the output will function as an outdoor damper. Which means for fresh air the output will modulate to 100%. If A01 is set to 2, it will work as a return air damper and it thus works inverse to the outdoor damper. For fresh air, it will go to 0%.

13.8 Run time counter (d09)

Run time counters can be used to sum up the accumulated runtime of a device connected to a digital output. The counter runs up to 65536 hours and saves the run time every hour to EEPROM. The run time hours and the status of the digital output will be displayed when stepping through the available display pages with the operation terminal.

13.8.1 Maintenance alarm (d10)

The run time counter may be used to trigger a maintenance alarm once a certain run time is exceeded. Select limit to trigger a maintenance alarm. The limit is selectable in steps of 256 hours. Setting the time to 0 disables the maintenance alarm. *Note: An alarm must be assigned to maintenance alarm by setting ALO = 3 on one alarm.*

13.9 Switch digital output based on input value

Activate the function with d01 = 9. Select the input with d02 and define the switching limits with d14 and d15. Reversing the switching limits, will reverse the switching function of the output.

Note: The switch based on inputs is as well used for the light switch function.

13.10 Lead – Lag function

The lead – lag function is defined in the fan module. A digital output can be assigned to a lead – lag function. Either as stage that will be rotated based on the settings of the function or as standby output. The standby output will be activated when a stage output fails. Only one standby output can be activated per lead – lag function.

Each output assigned to a stage may be disabled using interlocks or alarms. In this case it is disabled, the lead – lag function activates the next stage.

13.11 Override mode

Override mode can be enabled to temporarily manually control an output for commissioning or service purposes. When override mode is enabled, the configurations defined with xd00 to xd03, as well as the alarm and interlock configurations (xd07/xd08), are ignored. The output enters manual mode and can be set to a desired output level. The output level set in this way is defined by the manual setpoint of the corresponding output.

This setting may be activated in BACnet by setting the analog output state object "DO-XX-ST" to "4 = Override".

13.12 Parameter reference for digital output configuration

Parameter	Description	Range	Default
xd 01	Select control loop or special function 0 = Not active 1 = Loop 1 2 = Loop 2 3 = Loop 3 4 = Loop 4 5= Special functions (Dehumidification, Economizer, etc.) 6= Manual positioning, time schedule controlled, I/O module mode 7= Controller state functions 8 = Max of loop 1 and loop 2 9 = Digital output assigned to an input 10 = Digital output assigned to lead/lag module	0 – 10	0
xd 02	When xd01=1-4 configure output in loop mode: 0= Heating/reverse 1= Cooling/direct 2= Heating and cooling (2 pipe) 3= On if loop in heating mode: Reversing valve mode 4= On if loop in cooling mode: Reversing valve mode 5= On while demand in heating or cooling mode	0 – 15	0
	When xd01=5, select function: 0 = Dehumidification: Max of loop 1 cooling and loop 2 dehumidifying sequence. 1 = Economizer: Outdoor air damper actuator. See 5FU for more details. 2 = Economizer: Return air damper actuator. See 5FU for more details.		
	When xd01 = 6 Manual positioning, time schedules, I/O module mode 0 = Allow time schedule only 1 = Allow manual positioning and time schedules 2 = I/O module mode 3 = I/O module mode and manual positioning		
	When xd01=7 select state functions: 0= ON if controller operation state is ON 1= ON while demand on any output 2= ON while controller in heating mode 3= ON while controller in cooling mode 4= ON if controller state is occupied, OFF if unoccupied		

Parameter	Description	Range	Default
	<p>When xd01 = 8 Maximum of output of loop 1 and loop 2</p> <p>0 = Loop 1: Heating, Reverse Loop 2: Heating, Reverse 1 = Loop 1: Cooling, Direct Loop 2: Heating, Reverse 2 = Loop 1: Heating and Cooling Loop 2: Heating, Reverse 3 = Loop 1: Heating, Reverse Loop 2: Cooling, Direct 4 = Loop 1: Cooling, Direct Loop 2: Cooling, Direct 5 = Loop 1: Heating and Cooling Loop 2: Cooling, Direct</p> <p>When xd01 = 9: Select input. Switching limits are defined with xd14 and xd15: Input according hardware: 0 = disabled, 1 = UI1, 2 = UI2, etc.</p> <p>When xd01 = 10: Select module for lead/lag module. 0 = module 1 not demand based 1 = module 1, if demand on loop 1, heating only 2 = module 1, if demand on loop 1, cooling only 3 = module 1, if demand on loop 1 heating & cooling 4 = module 2 not demand based 5 = module 2, if demand on loop 2, heating only 6 = module 2, if demand on loop 2, cooling only 7 = module 2, if demand on loop 2 heating & cooling</p>		
xd 03	<p>When xd01=1-4: Select sequence 0 = Operation mode, Output is active when mode is active 1 = binary mode: Stage 1 to 6 = binary mode: Stage 6</p> <p>When xd01=6, 7 and 9: Select reaction on on/off/disable operation mode 0 = output is off, when operation mode is off 1 = output is off, when operation mode is disabled 2 = operation mode has no effect on output</p> <p>When xd01=10 Select stages for lead – lag module 0 = standby (only for lead – lag module), 1 = output 1, 2 = output 2, 3 = output 3</p>	0 - 6	0
xd 04	Switch off delay: Time the output signal needs to be off, before output switches off Special function in PWM mode, see next chapter	00:00s...15:10h MM:SS...HH:MM	01:30
xd 05	Switch on delay: Time the output signal needs to be on, before output switches on. With state functions, all control outputs are disabled during switch ON delay. Special function in PWM mode, see next chapter	00:00s...15:10h MM:SS...HH:MM	00:05
xd 06	Activate PWM, set cycle time, seconds (>0 activates, 0 deactivates PWM and enables digital mode)	00:00s...15:10h MM:SS...HH:MM	00:00
xd 07	Choose alarm to set output to ON (output OFF on conflicting alarms) Alarm: 1 2 3 4 5 6 7 8	Triangle shown = alarm selected	▽▽▽▽▽▽▽▽
xd 08	Choose alarm to set output to OFF (output OFF on conflicting alarms) Alarm: 1 2 3 4 5 6 7 8	Triangle shown = alarm selected	▽▽▽▽▽▽▽▽
xd 09	d09 and d10 only function if output is in digital mode: OFF: Do not count run time and reset counter to 0 ON: Count run time in hours while a digital output is switched on	ON/OFF	OFF
xd 10	<p>For binary mode: Trigger function alarm when run time is reached (may be used as maintenance alarm), 0 = alarm disabled</p> <p>In PWM mode: Intermediate alarm: In case the same alarm is selected in xd07 and xd08, the output will be set to the here defined level, in case the alarm activates.</p>	0 - 12750h 0 - 100%	0 0%
xd 11	Uses PI sequence instead of binary sequence of PI loop <i>Note: changing this value, will automatically as well change xd13.</i>	ON/OFF	OFF
xd 12	Activation limit if based on PI (xd01 = 1-4 AND xd11 = ON), if value above this limit, output switches on. <i>Note: Linked parameter: changing this value, will change as well xd14</i>	0 - 100%	50%
xd 13	Deactivation limit if based on PI (xd01 = 1-4 AND xd11 = ON), if value below this limit, output switches off. <i>Note: Linked parameter: changing this value, will change as well xd15</i>	0 - 100%	40%
xd 14	If based on UI (xd01 = 9): In binary mode: Activation limit. If value is above this limit, output switches on. In PWM mode: this is the lower limit of the input range <i>Note: Linked parameter: changing this value, will change as well xd12</i>	Per input limit	50%
xd 15	If based on UI (xd01 = 9): In binary mode: Deactivation limit: if value is below limit, output switches off. In PWM mode: this is the upper limit of the input range <i>Note: Linked parameter: changing this value, will change as well xd13</i>	Per input limit	10%
xd 16	Activate override mode The output is put into manual mode, settings from xd00 - xd02 and xd 07, xd 08 are ignored	ON/OFF	OFF

Note: xd represents the index of the actual used output 1 - n according to the X2 product.

13.13 Digital output in PWM configuration (d00 = OFF / d06 ≠ 0)

13.13.1 Activating Pulse Width Modulation (PWM)

Pulse width modulation (PWM) mode is enabled once a cycle time is defined in d06. In PWM mode the digital output will be switched on/off once per cycle. The on and off times are calculated according to the PI settings of the respective control sequence. It is not recommended to use cycle times below 10 Minutes for relays outputs as the lifetime of the relays will be shortened with frequent switching. The settings are identical to the output in digital configuration. Only difference is for parameter d04 and d05:

13.13.2 Minimum and maximum limits for PWM outputs

Using d04 and d05 the on time of the PWM signal may now be limited to the value defined with d05. After the limitation has been exceeded the output will cycle with a frequency that is defined with d04. Setting d05 = 00:00 will deactivate the limitation function.

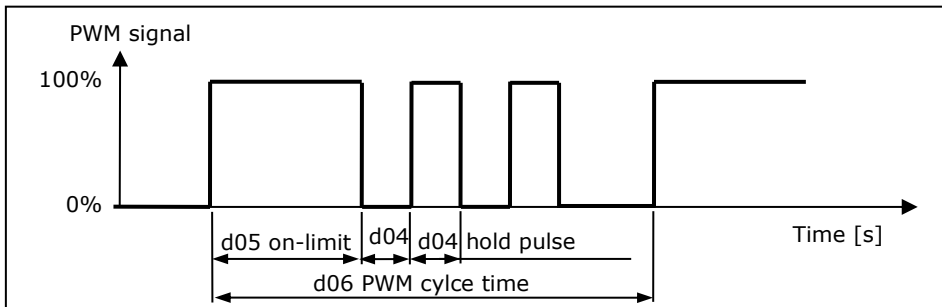

Parameter	Description	Range	Default
xd 04	In PWM mode: Hold pulse if on-limit is reached. This feature is used to reduce energy consumption for example for wax type valves where the wax is heated to open the valve.	00:00s...15:10h MM:SS...HH:MM	01:30
xd 05	In PWM mode: Energy-limiter: Maximum ON time for PWM outputs, Output will be limited to be active during the time indicated here. After the value is exceeded, it will switch on and off based on frequency defined with xd04. <i>Note: setting this value to 00:00 deactivates the time limitation.</i>	00:00s...15:10h MM:SS...HH:MM	00:05
xd 06	Activate PWM, set cycle time, seconds (>0 activates, 0 deactivates)	00:00s...15:10h MM:SS...HH:MM	00:00

Note: xd represents the index of the actual used output 1 - n according to the X2 product.

14 Auxiliary functions

14.1 1FU: Enable/disable of controller

14.1.1 Summary

The controller may be switched off/on based on an alarm or an input. The alarm status register may be used as OR-function where the controller is only allowed to function when all monitored conditions are within their correct value.

If it was enabled or disabled through an alarm condition it will return to the mode it was prior to the alarm, once the alarm is not active anymore without delay.

14.1.2 Priority

1. Disable by alarms or interlocks with 1Fu7, switch off delay applies.
2. Enable by alarms or interlocks with 1Fu8, startup delay applies.
3. Time schedules (OP)
4. Enable through input condition selected in 1Fu0
5. Manual on/off (Reset time defined with UP18)

14.1.3 Manual override

Once an input is assigned to the 1FU0, it may only be manually controlled if manual override is enabled with 1FU1. During manual override, the hand symbol is shown on the operation terminal.

This function is required, where the controller needs to create the allowed input condition for example by running a fan while differential pressure is used as enable condition.

14.1.4 Delays

The enable delay 1FU2 defines the time required for correct conditions to apply before the controller will activate.

The disable delay 1FU3 allows the controller to run in manual even the condition for enable are not met. If these conditions are still not met after the delay expires, the controller will turn off again.

14.1.5 Signal limits

There are two limits involved for enabling the controller. Depending on parameter 1FU4 they behave differently.

1FU4 = OFF: When limit 2 (e.g. 60) is larger than limit 1 (e.g. 40) the controller will be enabled when the input value is greater than limit 2 (e.g. 60) and disabled when the input value is below limit 1 (e.g. 40). When limit 2 (e.g. 40) is lower than limit 1 (e.g. 60) the controller will be enabled when the input value is lower than limit 1 (e.g. 40) and disabled when the input value is above limit 2 (e.g.10).

1FU4 = ON: When limit 2 (e.g. 60) is above limit 1 (e.g. 40) the controller will be enabled when the input value is between limit 1(e.g. 40) and limit 2 (e.g. 60). When limit 2 (e.g. 40) is below limit 1 (e.g. 60) the controller will be enabled when the input value is below limit 2 (e.g. 40) or above limit 1 (e.g. 60).

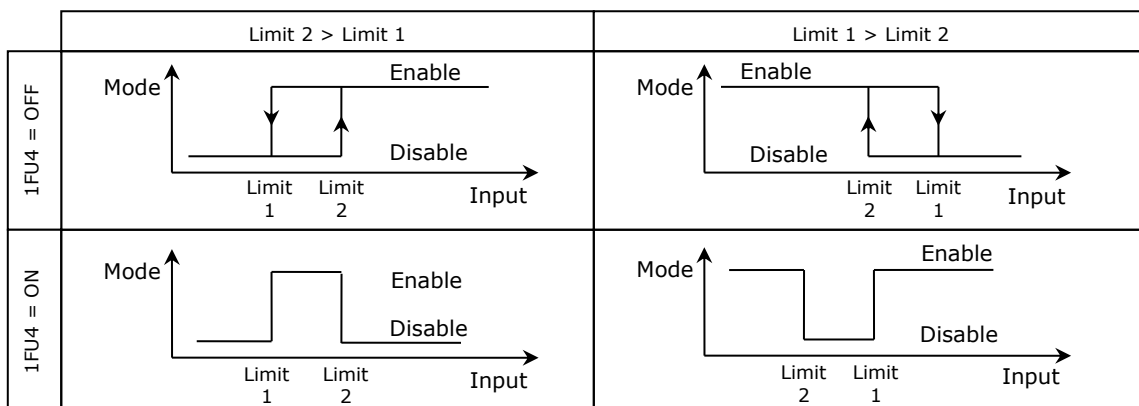

14.1.6 1Fu Parameter reference

Parameter	Description	Range	Default
1Fu 0	Select input for remote enable function: Input according hardware: 0 = disabled, 1 = UI1, 2 = UI2, etc.	0 - 12	0
1Fu 1	Manual override permitted (without waiting for delay).	ON/OFF	OFF
1Fu 2	Startup delay (seconds) = the time the enable condition must be met before the controller is switched on.	00:00s...15:10h MM:SS...HH:MM	05:00 MM:SS
1Fu 3	Switch off delay (seconds) = the time the disable condition must be met before the controller is switched off.	00:00s...15:10h MM:SS...HH:MM	05:00 MM:SS
1Fu 4	Range of limits (See table below for graphical explanation):	ON/OFF	OFF
1Fu 5	Input limit 1 (See 1Fu 4 for description)	Per input range	10
1Fu 6	Input limit 2 (See 1Fu 4 for description)	Per input range	90
1Fu 7	Disable controller in case selected alarms are active <i>Note: Switch-off delays still apply when an alarm becomes active</i>	Triangle shown = alarm selected	▽▽▽▽▽▽▽▽
1Fu 8	Enable controller in case selected alarms are active <i>Note: Switch-on delays still apply when an alarm becomes active</i>	Triangle shown = alarm selected	▽▽▽▽▽▽▽▽

14.2 2Fu: Control occupied and unoccupied mode

14.2.1 Summary

This function controls the occupied mode with one or two inputs. This operation mode may be controlled straight forward with one input such as a key card or conditional by using one input as an enable input such as a door contact and the other one as a conditional input such as a presence sensor. In order to use occupied/unoccupied mode UP06 must be set to ON.

This function only switches the operation mode. The behavior of each control loop in unoccupied mode must be defined with L07 and L27 in each loop concerned.

14.2.2 Activation

Activate function by selecting the input to control occupied/unoccupied mode.

14.2.3 Input limits

Set the limits (2FU2 and 2FU3) to the input values that indicate when the room is occupied or unoccupied. The input used may be straight forwards such as a key card switch or a motions sensor, or it can be more sophisticated such as a CO2 sensor or door contacts.

Following are the occupied/unoccupied mode switch possibilities:

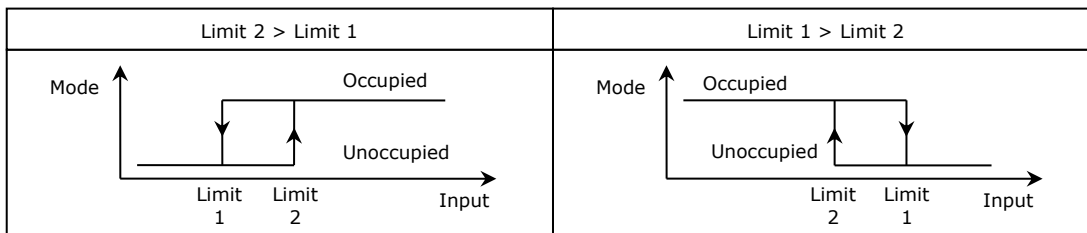

14.2.4 Fool-proof presence detection

For door contact applications: The use of a key switch may be avoided by using a door contact and a motion detector. The motion detectors should be placed in each room in order to detect the presence of an occupant. The room will automatically go to unoccupied mode once the door is opened and closed again and if there is no movement in the room after the door closes. The delay of the motion detector MUST therefore be less than the unoccupied mode delay defined with 2FU1; else the controller will stay in occupied mode. Ideal is to keep the delay of the motion detector output to below 30 seconds.

The moment there is movement in the room or the door is opened; the room will go to occupied mode again and will not go to unoccupied unless the door is opened and closed again.

14.2.5 Disabling occupied mode with interlocks

With 2FU5 interlocks may be identified that prevent occupied mode. These interlocks can be connected to door or window contacts. This can be used to prevent the cooling to operate while a window is open in the room.

14.2.6 2Fu Parameter reference

Parameter	Description	Range	Default
2Fu 0	Select input for remote occupied - unoccupied change function: Input according hardware: 0 = disabled, 1 = UI1, 2 = UI2, etc.	0 - 12	0
2Fu 1	Unoccupied mode delay (seconds) = the time the input needs to be inactive before the controller switches to unoccupied mode.	00:00s...15:10h MM:SS...HH:MM	05:00 MM:SS
2Fu 2	Input limit 1 to signal unoccupied or door opened	Per input range	10
2Fu 3	Input limit 2 to signal occupied or door closed	Per input range	90
2Fu 4	Select input for door contact in combination with input defined under 2Fu 0: 0 = not active, 1 = UI 1 to 10 = VI4 If door contact input is defined, the controller will only go to unoccupied mode, if the door is opened and after the door closes, there is no movement registered on the input selected in 2Fu 0	0 - 12	0
2Fu 5	Select interlocks or alarms for window contact. If any interlock activates, the function will change to unoccupied mode, independent of door state.	Triangle shown = alarm selected	▽▽▽▽▽▽▽▽

14.3 3Fu: Control heating and cooling mode

14.3.1 Summary

Each control loop has its own heat and cool mode. The controller has as well a heat / cool mode. This mode is visible in the idle screen and can be manually changed by advanced user access if enabled.

The control loop may now be configured in such a way that it is demand based and switches its heat/cool mode based on demand automatically (L24 = OFF) or that it follows the heat cool mode of the controller (L24 = ON).

The heating or cooling state of the controller may be controlled from a central location by a digital contact or temperature level of outside air or supply media. The mode may also depend on heating or cooling demand of a control loop.

14.3.2 Controlling heat/cool mode with an input

Set limit 1 and limit 2 to switch between heating and cooling with options below:

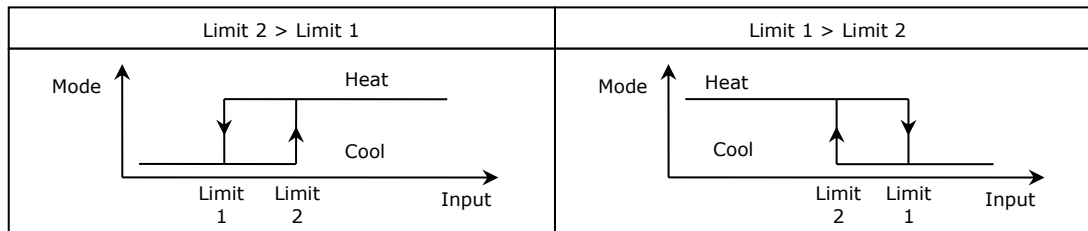

14.3.3 By open contact

When switching heating/cooling state with an external switch set input to RT/DI mode and connect switch to signal ground. Ground levels of all involved controllers must be the same.

14.3.4 By outdoor or supply media temperature

For supply media temperature we recommend switching to cooling at limit1 = 16°C/61°F and to heating at limit2 = 28°C/83°F. For outdoor temperature we recommend switching to cooling at limit1 = 28°C/83°F and to heating at limit2 = 16°C/61°F outdoor temperature.

Above recommendations are given as suggestions. The ideal settings may be different on the actual project depending on climatic and system conditions.

14.3.5 Controlling heat/cool settings with a control loop

By selecting a control loop with 3FU1, the heat/cool setting of the selected control loop is used to determine the heat/cool mode of the controller. This is the preferred way for simple installations that only have one control loop and use the idle display.

Note: the input selection on 3FU0 must be set to 0 and the control loop used in such a way must be set to demand-based heating and cooling with (L24 = OFF).

14.3.6 3FU Parameter reference

Parameter	Description	Range	Default
3Fu 0	Select input for remote heat – cool change function: 0 = not active or based on control loop, Input according hardware: 0 = disabled, 1 = UI1, 2 = UI2, etc.	0 - 12	0
3Fu 1	If heat – cool mode is based on a control loop, select control loop here. (3Fu 0 must be set to 0) 0 = Based on universal input, 1 = LP1, 2 = LP2, etc.	0 - 4	0
3Fu 2	Activation delay (Seconds) = delay before heat – cool mode is switched. This delay is to avoid unnecessary switching	00:00s...15:10h MM:SS...HH:MM	05:00 MM:SS
3Fu 3	Input limit 1 (Cool limit) applies only if based on input	Per input range	20%
3Fu 4	Input limit 2 (Heat limit) applies only if based on input	Per input range	40%

14.4 4FU: Summer/winter setpoint compensation

14.4.1 Summary

Summer/winter compensation changes the set point due to a change in an input value, typically, but not limited to, an outdoor temperature input. Activate summer/winter compensation with control loop configuration parameter (L05).

There are two ways to shift the setpoint of a control loop based on an input. One is through an offset and the other one is with a setback.

14.4.2 Setpoint offset (4FU1 = OFF)

The offset shifts the setpoint in a linear fashion based on the measured value of an input.

4FU4 defines the value of the input where the shift is 0. This can be 50% for a UP/DOWN shift or 0% / 100% for a one directional shift.

4FU3 defines the change required in input signal for one step change of the setpoint. If set to 5%, each time the input is increased by 5% the setpoint would increase by one step.

4FU2 sets a direct or reverse behavior of the input versus setpoint change. In direct mode the setpoint increases when the input increases, in reverse mode, the setpoint decreases when the input increases.

14.4.3 Setpoint setback (4FU1 = ON)

In setback the setpoint is pulled towards the upper or lower setpoint limits of the control loop depending on an input based on diagram below.

Winter compensation starts when outside temperature drops below the upper limit of winter compensation (4FU4). At maximum winter compensation the actual set point will be equal to the control loop's minimum or maximum heating set point depending on the setting of 4FU2.

Summer compensation starts when outside temperature exceeds the lower limit for summer compensation (4FU5). At maximum summer compensation the actual set point will be equal to the control loop's minimum or maximum cooling set point depending on 4FU5.

Setting 4FU8 = ON indicates the state of compensation on the display by showing a heat – cool symbol.

Set point set back 4FU1 = ON

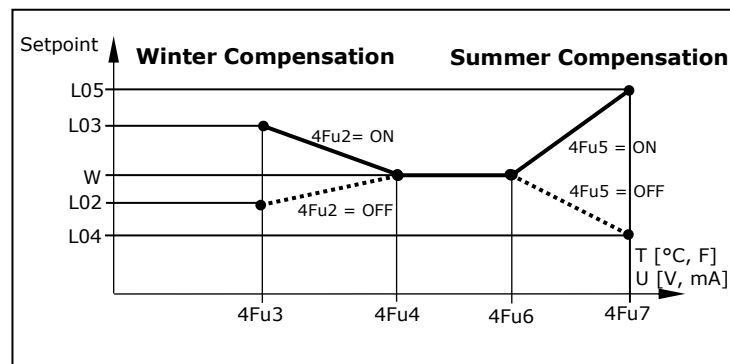

14.4.4 4FU Parameter reference

Parameter	Description	Range	Default
4Fu 0	Selection of Compensation Input Input according hardware: 0 = disabled, 1 = UI1, 2 = UI2, etc.	0 - 12	0
4Fu 1	Type of compensation OFF = Offset: The setpoint shifts up or down based on an input signal ON = Setback: The setpoint is shifted towards loop setpoint min max based on an input signal.	ON/OFF	OFF

Offset setpoint compensation: 4Fu1 = OFF

Parameter	Description	Range	Default
4Fu 2	Shift is direct or reverse acting OFF = Direct: Rising input value increases setpoint ON = Reverse: Rising input value decreases setpoint	ON/OFF	OFF
4Fu 3	Input span required to shift setpoint one step:	Per input range	10
4Fu 4	Input where setpoint shift is = 0, This defines the value of the input signal where the control set point is not compensated	Per input range	50

Setback setpoint compensation: 4Fu1 = ON

Parameter	Description	Range	Default
4Fu 2	Winter Compensation: OFF = setpoint is shifted negative to lower setpoint limit ON = setpoint is shifted positive to upper setpoint limit	ON/OFF	OFF
4Fu 3	Winter Compensation (Setpoint shift with low compensation signal) Lower Limit: input signal with maximum setpoint shift	Per input range	10
4Fu 4	Winter Compensation (Setpoint shift with low compensation signal) Upper Limit: Input signal at begin of setpoint shift.	Per input range	50
4Fu 5	Summer Compensation: OFF = setpoint is shifted negative to lower setpoint limit ON = setpoint is shifted positive to upper setpoint limit	ON/OFF	ON
4Fu 6	Summer Compensation (Setpoint shift with high compensation signal) Lower Limit: input signal at begin of setpoint shift	Per input range	60
4Fu 7	Summer Compensation (Setpoint shift with high compensation signal) Upper Limit: Input signal with maximum setpoint shift.	Per input range	80
4Fu 8	Hot / Cool Symbol while compensation is active OFF= Hide symbol ON= Show symbol	ON/OFF	OFF

14.5 5Fu: Free heating or cooling (Economizer)

14.5.1 Summary

The aim of the economizer function is to reduce energy consumption by utilizing situations where cooling or heating requirements may be satisfied or supported by outdoor air.

14.5.2 Basic function

The economize function will first verify if there is demand from the loop. Once there is demand, it will compare the outdoor sensor with the return air sensor. If the situation is such that this would satisfy the demand, the outdoor damper will modulate. (for example if cooling mode, outdoor temperature or enthalpy is lower than the return air one.).

If in temperature sensor mode, it will check if the minimum difference outdoor temp to set point condition is fulfilled. If this is true, the economy cycle is activated for the time duration specified under 5FU5. If during this time the setpoint is reached, the counter will be reset. If not, mechanical cooling or heating will start once the delay is expired.

14.5.3 Hysteresis of 5FU4

5FU4 defines the minimum difference required between outdoor / indoor enthalpy or outdoor / loop setpoint temperature. Once these conditions are met and free heating / cooling is in effect only half of 5FU4 is required to keep them going. Once the difference is smaller than half of 5FU4, mechanical cooling will activate.

14.5.4 Activating free heating/cooling with 5FU0

To operate, the economizer needs to be assigned to a control loop with 5Fu0. There are several possibilities to determine if the condition for free heating or cooling is satisfied. The economizer operates differently depending on the sensors attached to it.

14.5.5 Based on two enthalpy sensors

Once there is heating or cooling demand, the economizer compares the enthalpy of return air with outdoor air. If the minimum difference condition defined with 5FU4 is met, mechanical heating or cooling is deactivated and the outdoor and return air dampers are modulated to achieve the predefined set point of the supply air. Once free heating or cooling is activated, only half of 5FU4 is required to maintain it. Mechanical cooling will resume, if the set point is not reached during the time specified in 5FU5 or difference drops below 5FU4/2.

The outdoor damper will modulate based on demand, as long as the outdoor enthalpy is below the return air enthalpy for free cooling or above it for free heating.

14.5.6 Based on two temperature sensors

Once there is heating or cooling demand, the economizer compares the setpoint with the outdoor air and return air temperature. If the minimum difference condition defined with 5FU4 is met, mechanical heating or cooling is deactivated and the outdoor and return air dampers are modulated to achieve the predefined set point of the supply air. Once free heating or cooling is activated, only half of 5FU4 is required to maintain it. Mechanical cooling will resume, if the setpoint is not reached during the time specified in 5FU5 or difference drops below 5FU4/2.

The outdoor damper will modulate based on demand, as long as the outdoor temperature is below the return air temperature for free cooling or above it for free heating.

With 5FU6 an interlock may be used to disable the economizer if the outdoor air humidity or outdoor air pollution is too high to provide free cooling.

14.5.7 Based on outdoor air temperature only

Once there is heating or cooling demand, the economizer compares the setpoint with the outdoor air temperature. If the minimum difference condition defined with 5FU4 is met, mechanical heating or cooling is deactivated and the outdoor and return air dampers are modulated to achieve the predefined set point of the supply air. Mechanical cooling will resume if the setpoint is not reached during the time specified in 5FU5.

With 5FU6 an interlock may be used to disable the economizer if the outdoor air humidity or outdoor air pollution is too high to provide free cooling.

14.5.8 Minimum required startup delay

All mechanical heating and cooling stages are required to have a minimum start up delay of 5 seconds enabled. This is in order to prevent unnecessary switching. In general, it is a good idea to have a 30 second delay on all outputs connected to the economizer module in order to prevent frequent switching due to changing weather conditions.

Important Note



All involved sensors must have the identical range settings (xu1 and xu2). This includes the sensor used for the control loop!

14.5.9 5FU Parameter reference

Parameter	Description	Range	Default
5Fu 0	Assign Economizer to a control loop 0 = economizer function is disabled 1 = assigned to control loop 1 - 2 = assigned to control loop 2	0 - 2	0
5Fu 1	Assign free heating or/and free cooling options 0 = economizer is disabled 1 = free heating is enabled 2 = free cooling is enabled 3 = free heating and free cooling is enabled	0 - 3	0
5Fu 2	Outdoor air sensor input (Temperature or Enthalpy): Input acc. hardware: 0 = disabled, 1 = UI1, 2 = UI2, etc. <i>Note: Data range must be identical to return air sensor selected in 5Fu3 and input sensor of loop selected in 5Fu0.</i>	0 - 12	0
5Fu 3	Return air sensor input (Temperature or Enthalpy): Input acc. hardware: 0 = disabled, 1 = UI1, 2 = UI2, etc. <i>Note: Data range must be identical to outdoor sensor selected in 5Fu2 and input sensor of loop selected in 5Fu0.</i>	0 - 12	0
5Fu 4	If temperature sensors are used: Choose difference between outside air temperature and loop setpoint required to activate free heating or cooling. If enthalpy sensors are used: Choose difference between outside air enthalpy and return air enthalpy required to activate free heating or cooling <i>Note: in order to prevent frequent activation / deactivation of mechanical heating or cooling, once conditions are met to activate free heating or cooling, only half the value of 5FU4 is required to maintain it.</i>	Per input range	0
5Fu 5	Delay time to activate mechanical heating or cooling in case supply air set point cannot be reached through free heating or cooling.	00:00s...15:10h MM:SS...HH:MM	05:00 MM:SS
5Fu 6	Disable economizer in case one of the selected interlocks/alarms is active. The interlocks may be assigned to outdoor humidity or pollution sensors	Triangle shown = interlock selected	▽▽▽▽▽▽▽▽

15 Time Scheduling

Up to 12 schedules based on time and day of the week may be programmed (Pr01 through Pr12). Schedules may change controller operation mode (ON/OFF, occupied, unoccupied), change fan state, directly position an output, or change a loop setpoint.

Summer / winter time changeover may be activated using user parameters.



The section "X2-" on page 3 gives an overview of the X2 devices that support time scheduling.

Note on Accuracy

Warning: The TCX2-40863 and X2 devices with a "C" addition (e.g. TRI2-FU-TH-221.202C) have a real-time clock with a maintenance-free power backup. This clock is accurate to two seconds a day.



Other TCX2 series devices may have no time functions or if they do, they calculate the time based on the processor's internal clock speed. This time source is accurate to approx. 2 minutes per day. If the controller uses its time program functions, it is therefore necessary to synchronize the time of these controllers at least every 24 hours with an exact time base.



Important Note

A blinking clock symbol on the terminal display indicates that the time has not been set or the unit was without power for longer than 48 hours. The time needs to be set to allow time schedules to operate.

15.1 Daily / Weekly time schedules

For details on how to set weekly time schedules with an operation terminal



- For X2 devices with button display refer to: "X2 operation manual for button display", document no. 70 - 00 - 0950.
- For X2 devices with touch button display refer to: "X2 Operation Manual for Touch Display", document no. 70 - 00 - 0951.

The operation instructions can be found on the Vector Controls home page www.vectorcontrols.com in the general X2 description or in the download section of the corresponding X2 product.



If the schedule type xTS 0 is set to 3 (analog output value), make sure that the analog output parameter xA 00 is also set to 6 (time schedules).

If the schedule type xTS 0 is set to 5 (binary output value), make sure that the digital output parameter xd 01 is also set to 6 (time schedules).

15.1.1 Parameter reference for daily / weekly time scheduling

Parameter	Description	Range	Default
xTS 0	Schedule type: 0 = Schedule is not active 1 = Controller Operation Mode 2 = Control Loop Setpoint 3 = Analog Output Value 4 = Fan State Control 5 = Binary Output Value 6 = Holiday Period	0 - 6	0
xTS 1	Time of the day from 00:00 to 23:45 (15-minute step)	00:00 ... 23:45 HH:MM ... HH:MM	00:00 HH:MM
xTS 2	Select the day of the week the schedule should apply to. ▽▽▽▽▽▽▽ Days: 1 2 3 4 5 6 7	Triangle shown = day selected	▽▽▽▽▽▽▽
xTS 3	Select the point this alarm should affect	0 - 6	1
xTS 4	The value to be applied.	0 - 100	0

15.2 Annual time schedules (holidays)

While an annual schedule (holiday) is active, the controller operating mode will change to OFF. Manual change of operation mode to ON for a certain duration is possible if it is enabled.



To enable manual change of operation mode, set the reset timeout in user parameter UP18.



Annual schedules have priority over other schedules. While an annual schedule is active, the weekly schedules will be inactive.

For details on how to set annual time schedules with an operation terminal



- For X2 devices with button display refer to: "X2 operation manual for button display", document no. 70 - 00 - 0950.
- For X2 devices with touch button display refer to: "X2 Operation Manual for Touch Display", document no. 70 - 00 - 0951.

The operation instructions can be found on the Vector Controls home page www.vectorcontrols.com in the general X2 description or in the download section of the corresponding X2 product.

15.2.1 Parameter reference for annual time scheduling

Parameter	Description	Range	Default
xTS 0	Schedule type: 0 = Schedule is not active 1 = Controller Operation Mode 2 = Control Loop Setpoint 3 = Analog Output Value 4 = Fan State Control 5 = Binary Output Value 6 = Holiday Period	0 - 6	0
xTS 1	Starting month	1 - 12	1
xTS 2	Starting day	1 - 31	1
xTS 3	Finishing month	1 - 12	1
xTS 4	Finishing day	1 - 31	1

16 Appendix

16.1 Change log V1.7A (from V1.6A)

- Add anti creep function and reconditioning function for RH sensors
- Add sensor input option Formaldehyde (SRD2)
- Add UP25, UP26, UP27, UP28 for SRD2 display options
- Add UP29 (installation altitude) for ambient pressure dependencies
- Add VI option ux00 = 5 for touch button input for SRD2-xxx-TOP(IR)
- Add I/O module mode for AO, DO, FAN
- Add new X2 devices TCX2-00863 (I/O modules)
- Add new TCV2 device
- Add new mode for 3-point floating control using on/off sequence instead of PI.
- Add override mode

16.2 Change log V1.6A (from V1.5A)

- SRD2 product types added.
- SRD2 idle display added.
- Low, medium and high-level display function added (SRD2 only).
- Passive infrared sensor PIR and dust sensor support added.
- Passive input description RT/DI (NTC) improved.
- Light control mode for motion detection added and description of toggle and dimmer mode updated.
- Time scheduling description improved.

16.3 Change log V1.5A (from V1.4)

- Virtual Inputs: A new setting was created to allow for use of accessory devices such as AEI-4UI. These accessories allow to add physical inputs to X2 devices.
- Extended delays for alarms are extended up to 10 days. Backwards compatibility: alarm delays of less than 8 hours were not affected. For longer than 8 hours they are increased with each step by first 4, then 8 and finally 12 hours. Therefore it is now possible to create alarms with a delay of up to 252 hours. This allows to create an alarm if for example setpoints are not met for an extended period of time.
- Binary outputs in PWM or 3-point-mode may now as well have an intermediate alarm setting. The run time alarm xd10 is used for this purpose. If one alarm is simultaneously assigned to both xd06 and xd07 instead of switching the output to 0 or 100% it will go to the level defined in xd10.
- Reverse sequences for analog outputs allowing for control of 6-way valves and air-side dampers. One sequence can be set to operate from 0 - 5V and the other from 5-10V with 5 V being the off position and for example 0V the full cooling and 10V the full heating position.
- Improved PI control setting. It is now possible to set the reset time by setting the Integral interval parameter to 0. Instead of entering KI the user can now specify the reset time that follows general control theory.
- Analog output in step mode. The limits of the analog output may be changed depending on which binary stages are active. This allows to complement several compressors with a modulating stage to allow for flawless demand-based load control.
- Repeated write requests with identical values to EEPROM from bus modules are ignored.
- Absolute humidity can now be calculated as new option of special function virtual inputs
- Thermodynamic conversion for refrigerants: pressure to temperature conversions are added to special function of virtual inputs.
- Scale factor is added to special function of virtual inputs
- Better (correct) handling of inputs with different multiplication setting for sensors and virtual inputs in special function mode.
- Enable controller through alarms or interlocks with 1FU8. An alarm selection register is added to activate controller if an alarm or interlock is active. This may be used for an after hours override contact or as frost protection. When enabled or disabled with alarms. The controller will return to the previous active mode after the alarm goes away.

Smart Sensors and Controls Made Easy!

Quality - Innovation – Partnership

Vector Controls GmbH
Switzerland

info@vectorcontrols.com

www.vectorcontrols.com

