



SCC2-P Air Differential Pressure Controller and Sensor

The SCC2-P is a programmable controller and sensor with communication capabilities. Each control loop may use 2 PI sequences and 2 binary stages. The SCC2-P comes with a built-in RS485 communication interface that allows peer-to-peer communication with an operation terminal such as OPT1-(2TH)-VC. Complete parameter sets may be copied by use of an accessory called AEC-PM2 or exchanged with a PC using an RS485-USB converter and the EasySet program. The SCC2-P uses the universal X2 operating system. Communication options are realized with Modbus TCP/RTU/ASCII and BACnet MS/TP or BACnet IP over WIFI.

Applications

- Pressure measurement in the field of heating, ventilation and air conditioning
- Measuring of air flow velocity
- Measuring and control of positive or negative pressure for example for clean rooms
- Supervision of critical pressures

Features

- Measures air differential pressure
- Pressure measurement from ± 125 Pa up to ± 2500 Pa (± 0.5 in H_2O to ± 10 in H_2O)
- "Zeroing" of differential pressure sensor supported
- Two universally configurable control loops:
 - Differential, averaging, min and max or square root functions.
 - Transmitter function for sensors and set points
- Universal analog outputs (VDC, mA)
- Relay output with a normally open and a normally closed contact (SPDT)
- 8 freely assigned alarm conditions, selectable state of outputs on alarm condition
- Password protected programmable user and control parameters

Product Testing and Certification



Declaration of
Conformity

Information on the conformity of our products can be found on our website
www.vectorcontrols.com on the corresponding product page under "Downloads".

Types and Ordering

Product Name	Product No.	Loop	DO	AO	Functions	AO1	AO2
SCC2-P2-200.101U-OP	40-300207	2	1	1	Differential pressure sensor and built-in display Pressure range ± 100 Pa (± 0.4 in H ₂ O)	Diff P	-
SCC2-P3-200.101U-OP	40-300208	2	1	1	Differential pressure sensor and built-in display Pressure range ± 500 Pa (± 2 in H ₂ O)	Diff P	-
SCC2-P2-200.101U-MOD	40-300210	2	1	1	Differential pressure sensor Pressure range ± 100 Pa (± 0.4 in H ₂ O) Communicating with Modbus RTU or ASCII	Diff P	-
SCC2-P3-200.101U-MOD	40-300211	2	1	1	Differential pressure sensor Pressure range ± 500 Pa (± 2 in H ₂ O) Communicating with Modbus RTU or ASCII	Diff P	-
SCC2-P4-200.101U-MOD	40-300300	2	1	1	Differential pressure sensor Pressure range ± 2500 Pa (± 10 in H ₂ O) Communicating with Modbus RTU or ASCII	Diff P	-
SCC2-P2-200.101U-BAC	40-300213	2	1	1	Differential pressure sensor Pressure range ± 100 Pa (± 0.4 in H ₂ O) Communicating with BACnet MS/TP	Diff P	-
SCC2-P3-200.101U-BAC	40-300214	2	1	1	Differential pressure sensor Pressure range ± 500 Pa (± 2 in H ₂ O) Communicating with BACnet MS/TP	Diff P	-

AO1 and AO2 are the analog outputs of the controller/sensor. The device is pre-programmed ex works as a transmitter. The sensors are assigned to the analog outputs according to the table.

Accessories

Product Name	Product No.	Description
<i>Built-in Operation Terminal</i>		
OPC2-S	40-500109	Optional built-in operation display for SCC2-P devices. Same display as order option "OP".
<i>External Operation Terminal</i>		
OPT1-FA-TNV-VC	40-500136	A large range of external operation terminals may be found on our website www.vectorcontrols.com . All -VC operation terminals work with this controller.
OPT1-FA-HTNV-VC	40-500135	
OPA2-VC	40-500007	
OPA2-2T-VC	40-500047	
OPA2-2HT-VC	40-500023	
OPF2-2T-VC	40-500159	
OPF2-2TH-VC	40-500158	
<i>Memory</i>		
AEC-PM2	40-500130	Plug-In memory module for fast copying of parameter sets
<i>Probe</i>		
AMP-1	40-510087	Differential pressure probes with 0.5m tube \varnothing 6mm

Safety



DANGER! Safety advice

This device is for use as an operating controller or sensor. It is not a safety device. Where a device failure could endanger human life and property, it is the responsibility of the client, installer and system designer to add additional safety devices to prevent such a device failure. Ignoring specifications and local regulations may cause equipment damage and endangers life and property. Tampering with the device and misapplication will void warranty.

Technical specifications

Power supply	Power requirements	24 VAC ±10%, 50/60 Hz, 12..34 VDC			
	Power consumption	Max. 5 VA			
	Safety extra low voltage (SELV)	HD 384, Class II			
	Electrical connection Wire size:	Screw terminal connectors for wire 0.75...1.5 mm ² (AWG 20...16)			
Signal inputs	Differential pressure sensor Static sensing type: Ceramic Measurement range	SCC2-P2	SCC2-P3	SCC2-P4	
		± 125 Pa (± 0.5 in H ₂ O)	± 500 Pa (± 2.0 in H ₂ O)	± 2500 Pa (± 10 in H ₂ O)	
	Error band after zeroing	< 1.25 % FSS	< 1%FSS	< 1 %FSS	
	Proof pressure (overload pressure)	7 kPa (1.0 psi)	14 kPa (2 psi)	14 kPa (2 psi)	
	Burst pressure	20 kPa (2.9 psi)	70 kPa (10 psi)	70 kPa (10 psi)	
Signal outputs	Analog outputs Output signal Resolution Maximum load	AO1 to AO2 0...10 VDC or 0...20 mA 9.76 mV or 0.019 mA (10 bit) Voltage: ≥1kΩ Current: ≤250Ω			
	Relay outputs: AC Voltage DC Voltage	0...48 VAC, full-load current 2A. 0...30 VDC, full-load current 2A			
	Insulation strength between relays contacts and system electronics: between neighboring contacts:	1500 VAC to EN 60 730-1 800 VAC to EN 60 730-1			
	Connection to remote terminal Hardware interface Cabling	RS485 in accordance with EIA/TIA 485 Twisted pair (STP) cable			
	Environment	Operation Climatic conditions Temperature Humidity	To IEC 721-3-3 class 3K5 0...50 °C (32...122 °F) <85 % RH non-condensing		
Transport & storage Climatic conditions Temperature Humidity Mechanical conditions		To IEC 721-3-2 and IEC 721-3-1 class 3K3 and class 1K3 0...50 °C (32...122 °F) <95 % RH non-condensing class 2M2			
Standards		Degree of protection	IP65 to EN 60 529		
		Pollution class	II (EN 60 730-1)		
	Safety class:	III (IEC 60536)			
	Overvoltage category	II (EN 60 730-1)			
General	Material	Flame retardant PC+ABS plastic (UL94 class V-0)			
	Dimensions (H x W x D)	47 x 98 x 90 mm (1.9 x 3.9 x 3.5 in)			
	Weight (including package) Product type -OP Product type -MOD/-BAC	222g (7.8 oz) 196g (6.9 oz)			

Technical specification communication for -MOD and -BAC types

Network	Hardware interface	RS485 in accordance with EIA/TIA 485
	Max nodes per network	128
Modbus (-MOD)	Max nodes per segment	64 (Vector devices only)
	Conductors	Shielded Twisted Pair (STP) cable
	Impedance	100 - 130 ohm
	Nominal capacitance	100 pF/m 16 pF/ft. or lower
	Galvanic isolation	The communication circuitry is isolated
	Line termination	A line termination resistance (120 ohm) shall be connected between the terminals (+) and (-) of the furthest node of the network
	Network topology	Daisy chain according EIA/TIA 485 specifications
	Recommended maximum length per chain	1200 m (4000 ft.)
	Communication standard	Modbus (www.modbus.org)
	Default setting	19200 baud rate, RTU 8 data bits, 1 even parity bit, 1 stop bit
Communication speed	4800, 9600, 19200, 38400	
Protocol: Data bits	RTU - 8 data bits, ASCII - 7 data bits,	
Parity - stop bit	no parity - 2 stops, even or odd parity - 1 stop	
BACnet (-BAC)	Communication standard	BACnet MS/TP over RS485 BTL tested and listed B-ASC
	Communication speed	9600, 19200, 38400, 57600, 76800, 115200



Technical specification for TCP/IP communication -WIM and -WIB types

Wi-Fi	Standards	Wi-Fi Alliance FCC/CE-RED/IC/TELEC/KCC/SRRC/NCC 802.11 b/g/n (802.11n up to 150 Mbps) A-MPDU and A-MSDU aggregation and 0.4 µs guard interval support
	Frequency range	2.4 GHz ~ 2.5 GHz
	Antenna	Internal
	Modbus TCP (-WIM)	Standard
BACnet/IP (-WIB)	Communication protocol	Modbus TCP (www.modbus.org)
	Transport Layer	TCP/IP
	TCP/IP Port	502
BACnet/IP (-WIB)	Communication standard	BACnet/IP BTL tested and listed B-ASC
	Transport Layer	UDP
	UDP Port	47808



Dimensions, mm (inch)

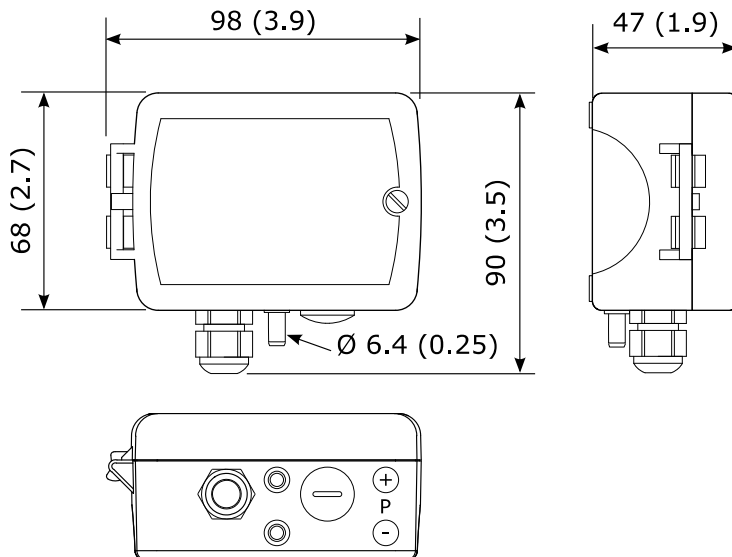

Sensors

Differential pressure sensor for –P-types

The controller measures the pressure by the use of a micro thermal flow sensor. The signal is temperature compensated and calibrated. The microprocessor samples the pressure once per second. It calculates an averaging signal over a preset number of seconds and generates an output signal based on minimum and maximum pressure values.

Square root function

The input signal is multiplied with a square root function. The signal curve will thus change to the typical square root shape. This is useful to directly measure and control air flows. As air flow is proportional to the square root of differential pressure. The picture on the right shows the shape of the square root function.

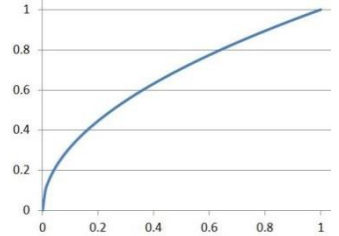

Signal fine tuning

The pressure-signal may be fine-tuned to fit your system. Define your signal through a minimum and maximum pressure limit. The output will then only react if the pressure is above the lower limit. The output signal will be spanned to the upper limit. The full output signal resolution may thus be used even only a fraction of the pressure sensor signal range is used. A 0-300 Pa transmitter may thus be converted into a 0-100 Pa transmitter. (Note: the sensing resolution will thus not be improved, only the output signal resolution)



For details see "X2 Engineering Manual", no. 70-00-0737.

Zeroing of Pressure Sensor

With the "Zeroing" function, it is possible to zero out a differential pressure that might be present at normal operation in a system. The "Zeroing" value is subtracted from the measurement at every sensor read. This allows for effective measuring the differential pressure in a system.



For optimal accuracy, we recommend repeating the "Zeroing" of the pressure sensor every 12 months.

Procedure

1. Open the SRD2 cover and power up the device.
2. Short press "ZERO" button on P-Sensor board.
3. For -P2 products: Status LED starts blinking.
For -P3 products: LED on P-Sensor board starts blinking.
4. Press "ZERO" button again.
5. After "Zeroing" is successful, LED lights up constant for 5 seconds.
If Zeroing is not successful (difference too large, signal not constant, etc)
The LED blinks for 10 seconds in 1 second interval.

Note: If "ZERO" button is not pressed again, the sensor will return to normal operation after 10 seconds.

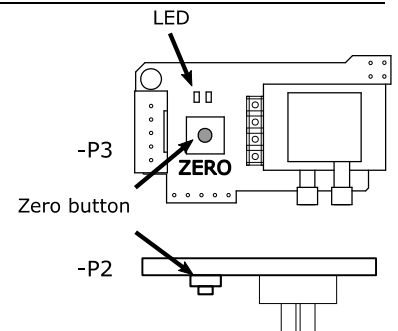

For details on how to open the device see "SCC2-P-200" install sheet, no. 70-00-0966.

Mounting and Installation

Mounting instructions



For details see: www.vectorcontrols.com

- "SCC2-P-200" install sheet, no. 70-00-0966

Connection diagram

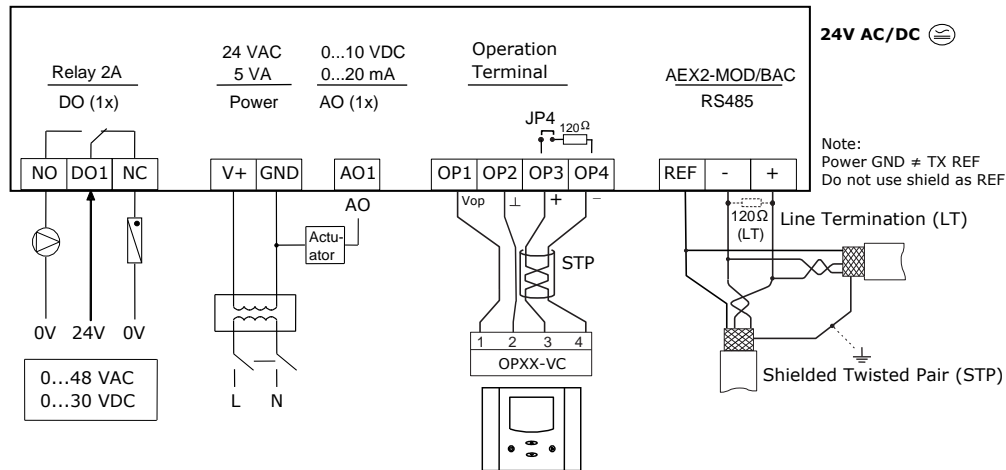

Jumper settings

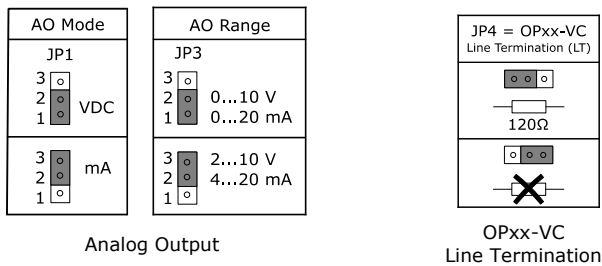

For details see: www.vectorcontrols.com

- "SCC2-P-200" install sheet, no. 70-00-0966

LED-indicators

A status LED is located inside of the controller housing. During normal operation the LED blinks briefly once every 5 seconds. If there is an alarm or fault condition it will blink every second. See also installation sheet point number D. The function of the system LED is explained in the engineering manual.

The Modbus slave or BACnet interface features a green LED and a red LED for indication of traffic on the RS-485 bus. The green LED is lit when an incoming packet is received, and the red LED is lit when an outgoing packet is transmitted to the bus. At power-up, both LED blink twice simultaneously as a sign of the boot process being completed. A constantly lit LED serves as an indication of a fault condition in the reception or sending process.

Wire type

An EIA-485 network shall use shielded, twisted-pair cable for data signalling with characteristic impedance between 100 and 130 ohms. Distributed capacitance between conductors shall be less than 100 pF per meter (30 pF per foot). Distributed capacitance between conductors and shield shall be less than 200 pF per meter (60 pF per foot). Foil or braided shields are acceptable.

Maximum length

The maximum recommended length per segment is 1200 meters (4000 feet) with AWG 18 (0.82 mm² conductor area) cable.

Operation and Configuration

▲ Documentation

This controller uses the latest generation X2 operating system. Detailed operation instructions for all devices equipped with this operating system can be found on our website.

Also available are programming instructions for technicians and an application database.

▲ Configuration



The device can be fully configured and commissioned using the EasySet program.

EasySet may be downloaded free of charge from our website www.vectorcontrols.com.

Documentation overview

Document Type	Document No.	Description
SCC2-P Data Sheet	70-00-0993	Product data sheet (this document)
SCC2-P-200 Install Sheet	70-00-0966	Mounting and installation manual for P type
X2 Operations Manual button display	70-00-0950	Operations instructions of X2 system with button display
X2 Engineering Manual	70-00-0737	Guidelines for configuring the X2 system
X2 Modbus Communication Module (-MOD type)	70-00-0290	Setup and configuration manual Modbus (no Modbus TCP)
X2 BACnet Communication Module (-BAC type)	70-00-0218	Setup and configuration manual BACnet (no BACnet/IP)

Note: The above list is not complete. The documents on the website are relevant.

BACnet (PICS)**Protocol Implementation Conformance Statement for BACnet MS/TP and BACnet IP network**

 The following is only valid for products with the **-BAC and -WIB** option.

Vendor Name: Vector Controls
Product Name: TRI2 Controls series
TRI2 product description: The TRI2 communicating BACnet controllers are designed as universal controls equipment suitable for a large number of applications. They may be used in zoning and other applications which are monitored by a BACnet MS/TP network.

▲ Supported BACnet Interoperability Blocks (BIBB)

The BACnet interface conforms to the B-ASC device profile (BACnet Application Specific Controller).
The following BACnet Interoperability Building Blocks (BIBB) is supported.

BIBB	Type	Name
DS-RP-B	Data sharing	Read property - B
DS-RPM-B	Data sharing	Read property multiple - B
DS-WP-B	Data sharing	Write property - B
DS-COV-B *1)	Data sharing	Change of value - B
DM-DCC-B	Device management	Device communication Control - B
DM-DDB-B	Device management	Dynamic device binding - B
DM-DOB-B	Device management	Dynamic object binding - B
DM-TS-B	Device management	Time synchronisation - B
DM-UTC-B	Device management	UTC Time synchronisation - B
DM-RD-B	Device management	Reinitialize device - B

*1) With -BAC, a maximum of 5 COV objects can be activated at the same time. This limitation does not apply to -WIB.

▲ Supported standard BACnet application services

- ReadProperty
- ReadPropertyMultiple
- WriteProperty
- DeviceCommunication (password protected)
- I-Am
- I-Have
- TimeSynchronisation
- UTCTimeSynchronisation
- ReinitializeDevice ("cold" or "warm") (password protected)

▲ Supported standard Object types

- Device
- Analog input
- Analog value
- Binary value
- Multi-state Value

X2 Functional Scope

The controller SCC2-200 has the following X2 functions and elements:

Group	Modules	QTY	Description
UP			User and display parameters
UI	01U to 05U	5	Sensor inputs for differential pressure
	06U to 09U	4	Virtual inputs for operation terminals, bus modules or special functions
AL	1AL to 8AL	8	Alarm conditions
LP	1L to 2L	2	Control loops
AO	1A	1	Analog output for mA, VDC
FAN	1F	1	Fan or lead lag modules, 1 to 3 fan speeds, up to 3 switching lead-lag stages each
DO	1d	1	Binary output with a normally open and a normally closed (SPDT) relays contact
FU	1FU	1	Remote Enable: Activation of the controller based on signal and alarm conditions
	2FU	1	Change Operation Mode: Switching occupied and unoccupied with control signals
	3FU	1	Heat/Cool Change: Switching heating and cooling based on a control signal
	4FU	1	Setpoint Compensation: Summer/winter compensation of setpoint
	5FU	1	Economizer (free heating or cooling due to the condition of outside and room air)
CO			Communication (if a communication module is available)
COPY			Copying complete parameter sets between run, default and external memory with up to 4 memory locations (AEC-PM2)



More detailed information on the X2 functions can be found in the "X2 Engineering Manual" on our website www.vectorcontrols.com.



For configuration see section "Operation and Configuration", page 7.

Smart Sensors and Controls Made Easy!

Quality - Innovation – Partnership

Vector Controls GmbH
Switzerland

info@vectorcontrols.com
www.vectorcontrols.com

