



Duct Controller and Sensor SDC2

The SDC2 is a programmable controller and sensor with communication capabilities. Each control loop may use 2 PI sequences and 2 binary stages. The SDC2 comes with a built in RS485 communication interface that allows peer-to-peer communication with an operation terminal such as OPT1-(2TH)-VC. Complete parameter sets may be copied by use of an accessory called AEC-PM2 or exchanged with a PC using an RS485-USB converter and the Easysset program. The SDC2 uses the universal X2 operating system.

Applications

- Ventilation control
- Temperature control
- Air humidifier and dehumidifier
- CO2 air quality control
- VOC air quality control
- Zone control

Functions

- Two universally configurable control loops:
 - Functions for dehumidifying, set point shift and cascade control
 - Multiple auxiliary functions: heat-cool auto changeover, automatic enable, set point compensation
 - Free heating and cooling with economizer function based on enthalpy or temperature
 - Differential, averaging, min and max functions, enthalpy and dew point calculations
 - Transmitter function for sensors and set points
- Measures:
 - Temperature
 - Humidity
 - CO2
 - VOC air quality
- Built-in humidity and temperature sensor (-TH type), CO2 sensor (-C type), VOC sensor (-Q type)
- Universal analog outputs (VDC, mA) and one relay with a normally open and a normally closed contact (SPDT)
- 8 freely assigned alarm conditions, selectable state of outputs on alarm condition
- Serial Modbus RTU/ASCII or BACnet MS/TP communication via isolated RS485
- Password protected programmable user and control parameters

Types and Ordering

Product Name	Product No.	LP	UI	DO	AO	Functions	AO1	AO2
SDC2-16-C-200.101U-1	40-300167	2	-	1	1	C = CO2 sensor TH = Temperature- and humidity sensor THQ = Temperature-, humidity- and VOC sensor THCQ = Temperature-, humidity-, CO2- and VOC sensor MOD = Communication with Modbus RTU or ASCII BAC = Communication with BACnet MS/TP	CO2	-
SDC2-16-TH-210.102U-1	40-300171	2	1	1	2		Temp.	RH
SDC2-16-TH-210.102U-MOD-1	40-300172	2	1	1	2		Temp.	RH
SDC2-16-TH-210.102U-BAC-1	40-300166	2	1	1	2		Temp.	RH
SDC2-16-THC-210.102U-1	40-300341	2	1	1	2		CO2	RH
SDC2-16-THC-210.102U-MOD-1	40-300174	2	1	1	2		CO2	RH
SDC2-16-THC-210.102U-BAC-1	40-300173	2	1	1	2		CO2	RH
SDC2-16-THQ-210.102U-1	40-300168	2	1	1	2		VOC	RH
SDC2-16-THQ-210.102U-MOD-1	40-300162	2	1	1	2		VOC	RH
SDC2-16-THQ-210.102U-BAC-1	40-300161	2	1	1	2		VOC	RH
SDC2-16-THCQ-210.102U-1	40-300164	2	1	1	2		CO2	VOC
SDC2-16-THCQ-210.102U-MOD-1	40-300165	2	1	1	2		CO2	VOC
SDC2-16-THCQ-210.102U-BAC-1	40-300163	2	1	1	2	CO2	VOC	

LP = Control loop, UI = Universal inputs, DO = Digital outputs, AO = Analog outputs

AO1 and AO2 are the analog outputs of the controller/sensor. The device is pre-programmed ex works as a transmitter. The sensors are assigned to the analog outputs according to the table.

Types and Ordering for Pre-Configured SDC2 Models

For a detailed description of how the pre-configured models work, see chapter "Pre-Configured Variants" on page 8.

Product Name	Product No.	Description	AO1	AO2	DO1
<i>Pre-Configured SDC2-16-TH Models (-Wx)</i>					
SDC2-16-TH-210.102U-1-W8	40-300171-8	W8 = Dew point sensor, ISO unit °C	See chapter "Pre-Configured Variants" on page 8		
SDC2-16-TH-210.102U-1-W28	40-300171-28	W28 = Dew point sensor, Imperial unit °F			
SDC2-16-TH-210.102U-1-W9	40-300171-9	W9 = Enthalpy sensor, ISO unit kJ/kg			
SDC2-16-TH-210.102U-1-W29	40-300171-29	W29 = Enthalpy sensor, Imperial unit BTU/lb			

Accessories

Product Name	Product No.	Description
<i>Built-in Operation Terminal</i>		
OPC2-S	40-500109	Optional built-in operation display for SDC2 devices
<i>External Operation Terminal</i>		
OPT1-xx	40-50xxxx	A large range of external operation terminals may be found on our website www.vectorcontrols.com . All -VC operation terminals work with this controller.
OPA2-xx	40-50xxxx	
<i>Memory</i>		
AEC-PM2	40-500130	Plug-In memory module for fast copying of parameter sets

Technical Specifications

Important notice and safety advice

This device is for use as an operating controller or sensor. It is not a safety device. Where a device failure could endanger human life and property, it is the responsibility of the client, installer and system designer to add additional safety devices to prevent such a device failure. Ignoring specifications and local regulations may cause equipment damage and endangers life and property. Tampering with the device and misapplication will void warranty.

Power supply	Operating voltage	24 VAC ±10%, 50/60 Hz, 12...34 VDC	
	Safety extra-low voltage (SELV)	HD 384, Class II	
	Power consumption	Max. 10 VA	
	Connector type	Screw Terminal connectors for wire 0.52...1.3 mm ² (AWG 20...16)	
Signal inputs	Temperature sensor	Bandgap sensor	
	Range	-40...70 °C (-40...158 °F)	
	Measuring accuracy	See Figure 1 under chapter sensors	
	Repeatability	± 0.1 °C, ± 0.2 °F	
	Humidity sensor	Capacity sensor element	
	Range	0...100% RH	
	Measuring accuracy	See Figure 2 under chapter sensors	
	Hysteresis	± 1%	
	Repeatability	± 0.1%	
	Stability	< 0.5% / year	
	CO2 sensor	Non-dispersive infrared (NDIR) waveguide technology with ABC automatic background calibration algorithm	
	Response time (90%)	2 Minutes	
	Measurement range	0 - 2000 ppm	
	Repeatability	± 20 ppm ± 1 % of measured value	
	Accuracy	± 40 ppm ± 3 % of measured value	
Pressure dependence	+ 1.6% reading per kPa deviation from normal pressure, 100 kPa		
Signal outputs	VOC sensor	MEMS metal oxide sensor with ABC automatic background calibration algorithm	
	Sensing range: TVOC (relative)	0 - 2000 ppb	
	CO2 equivalents (relative)	400 - 2000 ppm	
	Module	Automatic baseline correction	
	Passive input	UI6, Passive Temperature NTC or open contact	
	Type:	NTC (Sxx-Tn10) 10kΩ@25°C	
	Range	-40...100 °C (-40...212 °F)	
	Analog outputs	AO1 to AO2	
	Output signal	0...10 VDC or 0...20 mA	
	Resolution	9.76 mV or 0.019 mA (10 bit)	
Maximum load	Voltage: ≥1kΩ Current: ≤250Ω		
Connection to remote terminal	Relay outputs: AC Voltage (SPDT)	0...48 VAC, full-load current 2A	
	DC Voltage	0...30 VDC, full-load current 2A	
	Insulation strength between relays contacts and system electronics: between neighboring contacts:	1500V AC to EN 60 730-1 800V AC to EN 60 730-1	
Environment	Hardware interface	RS485 in accordance with EIA/TIA 485	
	Cabling	Shielded twisted pair (STC) cable	
Standards	Operation	To IEC 721-3-3	
	Climatic conditions	class 3K5	
	Temperature	0...50 °C (32...122 °F)	
	Humidity	<85 % RH non-condensing	
	Transport & storage	To IEC 721-3-2 and IEC 721-3-1	
	Climatic conditions	class 3K3 and class 1K3	
General	Temperature	-25...70 °C (-13...158 °F)	
	Humidity	<95 % RH non-condensing	
	Mechanical conditions	class 2M2	
	Degree of Protection	IP30 to EN 60 529 with CO2 / VOC sensor IP60 to EN 60 529 without CO2 / VOC sensor	
Standards	Pollution Class	II (EN 60 730-1)	
	Safety Class	III (IEC 60536)	
	Overvoltage Category	II (EN 60 730-1)	
	Material	Flame retardant PC+ABS plastic (UL94 class V-0)	
	Dimensions (H x W x D)	47 x 157 x 68 mm (1.9 x 6.2 x 2.7 in)	
	General	Weight (including package)	SDC2-16-C-200.101U-1: 290g (10.2 oz) SDC2-16-TH-210.102U-1: 290g (10.2 oz) SDC2-16-TH-210.102U-COM-1: 303g (10.7 oz) SDC2-16-THC-210.102U-COM-1: 310g (10.9 oz) SDC2-16-THQ-210.102U-1: 298g (10.5 oz) SDC2-16-THQ-210.102U-COM-1: 310g (10.9 oz) SDC2-16-THCQ-210.102U-1: 297g (10.5 oz) SDC2-16-THCQ-210.102U-COM-1: 310g (10.9 oz)
		COM = -MOD/-BAC	

Technical specification for serial communication, -MOD and -BAC types

Network	Hardware interface	RS485 in accordance with EIA/TIA 485
	Max nodes per network	128
	Max nodes per segment	64 (Vector devices only)
	Conductors	Shielded Twisted Pair (STP) cable
	Impedance	100 - 130 ohm
	Nominal capacitance	100 pF/m 16 pF/ft. or lower
	Galvanic isolation	The communication circuitry is isolated
	Line termination	A line termination resistance (120 ohm) shall be connected between the terminals (+) and (-) of the furthestmost node of the network
	Network topology	Daisy chain according EIA/TIA 485 specifications
	Recommended maximum length per chain	1200 m (4000 ft.)
Modbus (-MOD)	Communication standard	Modbus (www.modbus.org)
	Default setting	19200 baud rate, RTU 8 data bits, 1 even parity bit, 1 stop bit
	Communication speed	4800, 9600, 19200, 38400
	Protocol: Data bits Parity – stop bit	RTU - 8 data bits, ASCII – 7 data bits, no parity – 2 stops, even or odd parity – 1 stop
BACnet (-BAC)	Communication standard	BACnet MS/TP over RS485 BTL tested and listed B-ASC
	Communication speed	9600, 19200, 38400, 57600, 76800, 115200

Product testing and certification



Declaration of conformity

Information on the conformity of our products can be found on our website www.vectorcontrols.com on the corresponding product page under "Downloads".

Mounting and Installation

Sealing of cable entries



Important

All cable entries into the device must be sealed to prevent air drafts that could otherwise affect the sensors in the device and prevent correct measurements!

Installation instructions



For SDC2-200, refer to the installation sheet, document no. 70-00-0707 (www.vectorcontrols.com).

For SDC2-210, refer to the installation sheet, document no. 70-00-0664 (www.vectorcontrols.com).

Selection of actuators and sensors

Temperature sensors

Use Vector Controls NTC sensors to achieve maximum accuracy: SDB-Tn10-20 (duct), SRA-Tn10 (room), SDB-Tn10-20 + AMI-S10 as immersion sensor.

Actuators

Choose modulating actuators with an input signal type of 0/2-10 VDC.

3-point actuators with constant running time are recommended.

Binary auxiliary devices (e.g. pumps, fans, on/off valves, humidifiers, etc.)

Do not directly connect devices that exceed specified limits in technical specifications – observe startup current on inductive loads.

Connection diagram SDC2-200

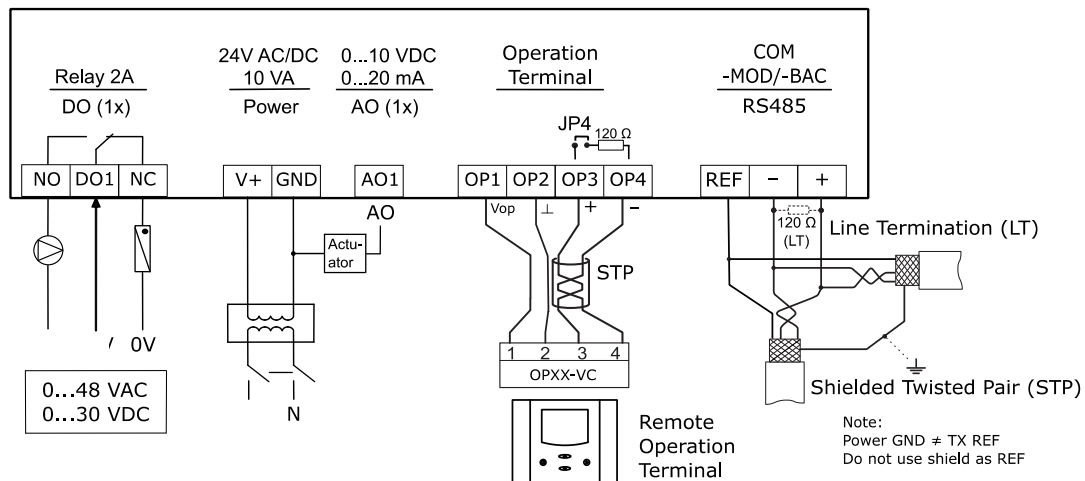

Connection diagram SDC2-210

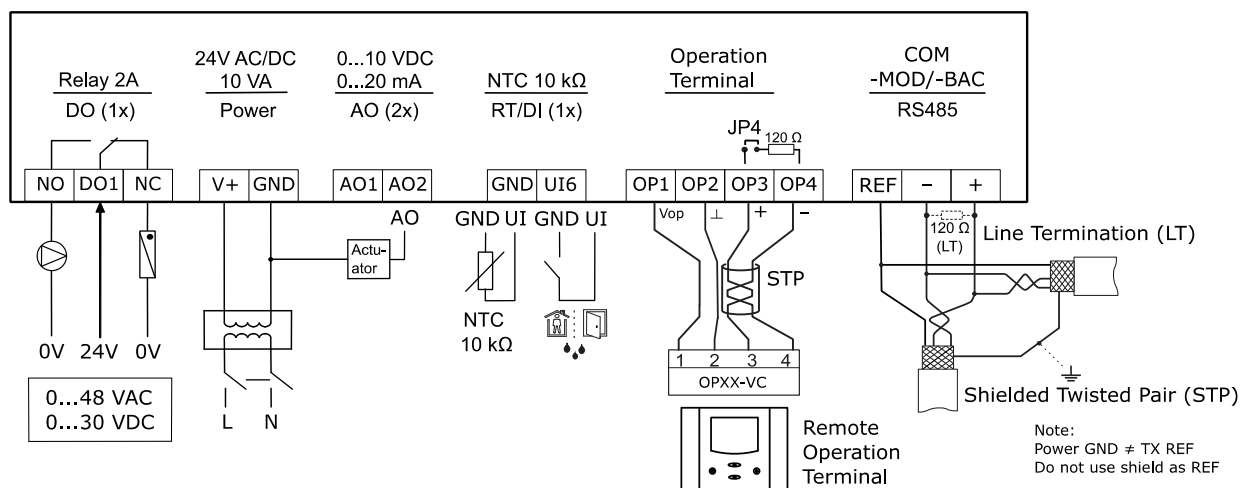

Jumper settings

SDC2-200			SDC2-210																																										
<table border="1"> <tr><td colspan="2">AO Mode</td></tr> <tr><td>JP1</td></tr> <tr><td>3 2 1</td></tr> <tr><td>VDC</td></tr> <tr><td>3 2 1</td></tr> <tr><td>mA</td></tr> </table>	AO Mode		JP1	3 2 1	VDC	3 2 1	mA	<table border="1"> <tr><td colspan="2">AO Range</td></tr> <tr><td>JP3</td></tr> <tr><td>3 2 1</td></tr> <tr><td>0...10 V</td></tr> <tr><td>0...20 mA</td></tr> <tr><td>3 2 1</td></tr> <tr><td>2...10 V</td></tr> <tr><td>4...20 mA</td></tr> </table>	AO Range		JP3	3 2 1	0...10 V	0...20 mA	3 2 1	2...10 V	4...20 mA	<table border="1"> <tr><td colspan="2">JP4 = OPxx-VC Line Termination (LT)</td></tr> <tr><td>120Ω</td></tr> <tr><td>X</td></tr> </table>	JP4 = OPxx-VC Line Termination (LT)		120Ω	X	<table border="1"> <tr><td colspan="2">AO Mode</td></tr> <tr><td>JP1/JP2</td></tr> <tr><td>3 2 1</td></tr> <tr><td>VDC</td></tr> <tr><td>3 2 1</td></tr> <tr><td>mA</td></tr> </table>	AO Mode		JP1/JP2	3 2 1	VDC	3 2 1	mA	<table border="1"> <tr><td colspan="2">AO Range</td></tr> <tr><td>JP3</td></tr> <tr><td>3 2 1</td></tr> <tr><td>0...10 V</td></tr> <tr><td>0...20 mA</td></tr> <tr><td>3 2 1</td></tr> <tr><td>2...10 V</td></tr> <tr><td>4...20 mA</td></tr> </table>	AO Range		JP3	3 2 1	0...10 V	0...20 mA	3 2 1	2...10 V	4...20 mA	<table border="1"> <tr><td colspan="2">JP4 = OPxx-VC Line Termination (LT)</td></tr> <tr><td>120Ω</td></tr> <tr><td>X</td></tr> </table>	JP4 = OPxx-VC Line Termination (LT)		120Ω	X
AO Mode																																													
JP1																																													
3 2 1																																													
VDC																																													
3 2 1																																													
mA																																													
AO Range																																													
JP3																																													
3 2 1																																													
0...10 V																																													
0...20 mA																																													
3 2 1																																													
2...10 V																																													
4...20 mA																																													
JP4 = OPxx-VC Line Termination (LT)																																													
120Ω																																													
X																																													
AO Mode																																													
JP1/JP2																																													
3 2 1																																													
VDC																																													
3 2 1																																													
mA																																													
AO Range																																													
JP3																																													
3 2 1																																													
0...10 V																																													
0...20 mA																																													
3 2 1																																													
2...10 V																																													
4...20 mA																																													
JP4 = OPxx-VC Line Termination (LT)																																													
120Ω																																													
X																																													
Analog Output			Analog Output																																										
OPxx-VC Line Termination			OPxx-VC Line Termination																																										



SDC2-200 jumper locations are shown on the Installation Sheet, document no. 70-00-0707.
SDC2-210 jumper locations are shown on the Installation Sheet, document no. 70-00-0664
(www.vectorcontrols.com).

Wiring of communication (RS485)

Wire type

An EIA-485 network shall use shielded, twisted-pair cable for data signaling with characteristic impedance between 100 and 130 ohms. Distributed capacitance between conductors shall be less than 100 pF per meter (30 pF per foot). Distributed capacitance between conductors and shield shall be less than 200 pF per meter (60 pF per foot). Foil or braided shields are acceptable.

Maximum length

The maximum recommended length per segment is 1200 meters (4000 feet) with AWG 18 (0.82 mm² conductor area) cable.

LED-indicators

A status LED is located in the controller housing. During normal operation the LED blinks briefly once every 5 seconds. If there is an alarm or fault condition it will blink every second. See also installation sheet point number D. The function of the system LED is explained in the engineering manual.

Modbus LED (-MOD type)

The Modbus interface features a green LED and a red LED for indication of traffic on the RS-485 bus. The green LED is lit when an incoming packet is received, and the red LED is lit when an outgoing packet is transmitted to the bus. At power-up, both LED blink twice simultaneously as a sign of the boot process being completed. A constantly lit LED serves as an indication of a fault condition in the reception or sending process.

BACnet LED (-BAC type)

The BACnet interface features a green LED and a red LED for indication of traffic on the RS-485 bus. The green LED is lit when an incoming packet is received, and the red LED is lit when an outgoing packet is transmitted to the bus. At powerup, both LED blink twice simultaneously as a sign of the boot process being completed. A constantly lit LED serves as an indication of a fault condition in the reception or sending process.

Dimensions, mm (inch)

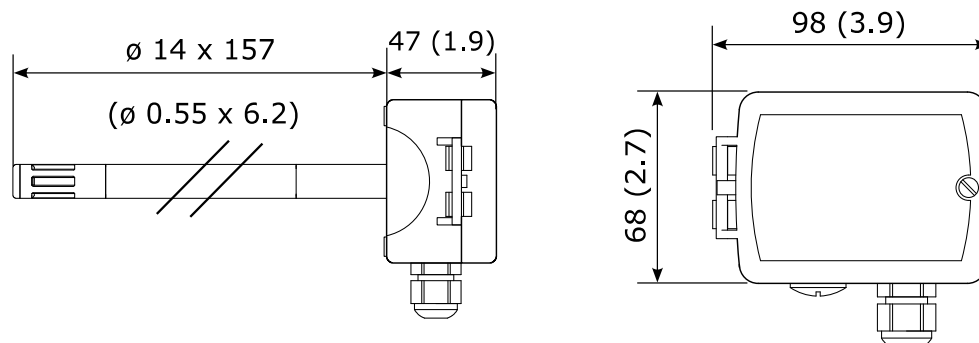

Sensors

Temperature sensors on -T- types

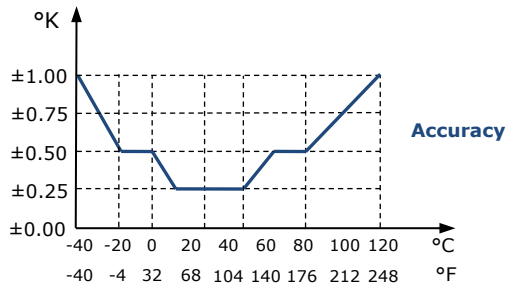

Figure 1: Max T-tolerance by sensor type

Temperature & Humidity from RH sensor on -HT- type

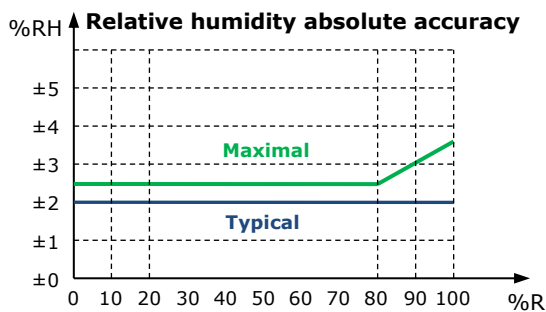

Figure 2: Max RH-tolerance at 25°C (77°F) per sensor type

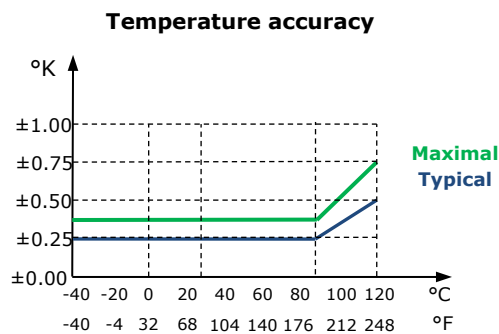

Figure 3: Max T-tolerance by sensor type

CO2 sensor for -C-types

The CO2 concentration is measured through non-dispersive infrared (NDIR) waveguide technology with ABC automatic background calibration algorithm. The applied measuring technology guarantees excellent reliability and long-term stability. The microprocessor samples the CO2 once per second. It calculates an averaging signal over a present number of seconds and generates the output signal.

Automatic baseline calibration ABC

The ABC background calibration constantly supervises the measured CO2 concentrations. The calibration function expects the CO2 values sink to 400 ppm when the room is not occupied. Over a period of several days the controller tries to reach this value step by step through recalibration of 30ppm per day max. In order to reach the given accuracy, it is required that the Sensor is for at least 3 weeks in operation.

i The ABC calibration works only in those applications where the CO2 concentration sinks regularly to fresh air levels of 400 ppm. For special applications such as green houses, animal farms, etc. the ABC calibration should be deactivated and the sensor should be manually calibrated. For details see "X2 Engineering Manual", section "Manual calibration of CO2 sensor", document no. 70-00-0737.

VOC (Air Quality Sensor) for -Q-types

Reliable evaluation of indoor air quality:

The sensing element used is a MOS (metal oxide semiconductor) based gas sensor component. It was specifically designed for a broad detection of reducing gases such as VOCs (volatile organic compounds) and CO (carbon monoxide) associated with bad air quality. The sensor has to run at least 24h for reliable VOC values. It has the following features:

- Sensing range: 400 – 2000 ppm CO2 equivalents and 0 – 2000 ppb TVOC equivalents
- High sensitivity and fast response
- Module with automatic baseline correction

Note

The VOC sensor is recommended as an actuator for multi-stage ventilation systems. The VOC values can be classified into the following air quality classes:

TVOC concentration [ppb]	0 – 60	60 – 200	200 – 610	610 – 1900	1900 – 2000
air quality class (EPA)	1	2	3	4	5
air quality	very good	good	moderate	unhealthy for sensitive groups	unhealthy

Pre-Configured Variants

Vector Controls offers a range of pre-configured SDC2 products for a wide variety of functions, including:

- Dew Point Sensor Function
- Enthalpy Sensor Function
- ...

The features of the preconfigured SDC2 products are explained in the following sections.

SDC2 Dew Point Pre-Configuration (-W8 / -W28 option)

When ordering the SDC2 with the -W8 or -W28 option, the SDC2 is preconfigured as a Dew Point Sensor. With the dew point configuration, the SDC2 provides the following features:

- Monitors the dew point or humidity level and activates a relay when the dew point or relative humidity exceeds the set limit.
- Stops condensation before it starts
- Analog output of dew point temperature and measured temperature
- Optional display (OPC2-S)

For ordering information, refer to the chapter "Types and Ordering for Pre-Configured SDC2 Models" on page 2.

Dew Point Function Settings

SDC2 Settings	-W8 (ISO Units)	-W28 (Imperial Units)
Output signal configuration		
AO1 Analog Output - Calculated dew point temperature	0...10 VDC = -40...60°C	0...10 VDC = -40...140°F
AO2 Analog Output - Current measured temperature	0...10 VCD = -40...60 °C	0...10 VCD = -40...140 °F
DO1 Digital Output (Changeover relay) - Dew point limit DRY - Dew point limit WET	NO to DO1 connected NC to DO1 connected	
Dew Point setting (default)		
Dew point limit WET - if current temperature is < dew point limit	2 °C	4 °F
Dew point limit DRY - if current temperature is > dew point limit	3°C	6 °F
Built-in display (OPC2-S)		
Standard Display - Dew point temperature - Current temperature	°C °C	°F °F

Wiring and Connection for Dew Point Pre-Configuration

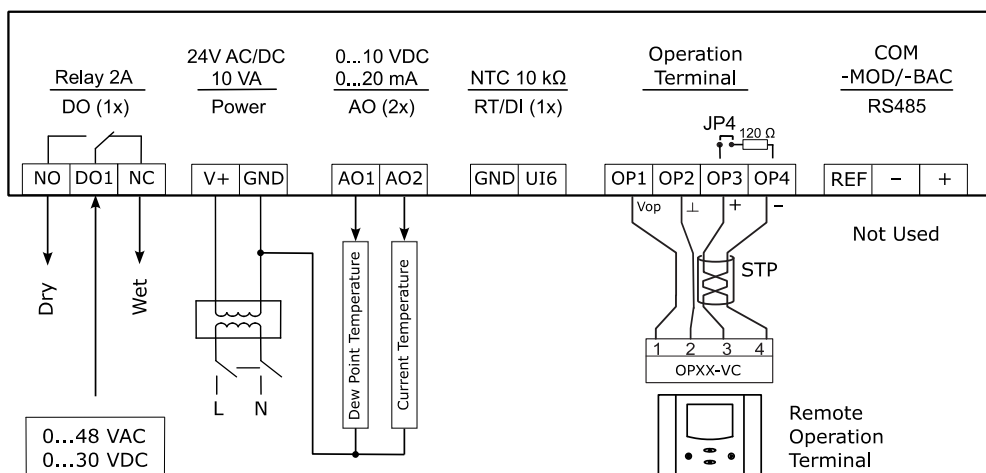

Adjusting the Dew Point Limits

To set the dew point limit values, refer to the parameter table below.

Configuration Parameters

The device can be fine-tuned by adjusting the software parameters. The parameters are set using the external operation terminal OPT1 / OPA2 or the free configuration tool EasySet.

Parameter	Description	Range	Default
1D 14	Dry: Reset current – dew point temperature	-40...215 °C/F	3°C
1D 15	Wet: Switching difference current - dew point temperature	-40...215 °C/F	2°C

SDC2 Enthalpy Pre-Configuration (-W9 / -W29 option)

When ordering the SDC2 with the -W9 or -W29 option, the SDC2 is preconfigured as an Enthalpy Sensor.

With the enthalpy configuration, the SDC2 provides the following features:

- The SDC2 calculates the Enthalpy (internal energy) of the current air
- Analog output of the Enthalpy value and relative humidity
- Optional display (OPC2-S)

For ordering information, refer to the chapter "Types and Ordering for Pre-Configured SDC2 Models" on page 2.

Enthalpy Function Settings

SDC2 Settings	-W9 (ISO Units)	-W29 (Imperial Units)
Output signal configuration		
AO1 Analog Output - Calculated Enthalpy of the humid air	0...10 VDC = 0...500 kJ/kg	0...10 VDC = 0...200 BTU/lb
AO2 Analog Output - Current measured temperature	0...10 VCD = -40...60 °C	0...10 VCD = -40...140 °F
DO1 Digital Output (Changeover relay)	Not active	
Built-in display (OPC2-S)		
Standard Display - Enthalpy of the air - Current temperature	kJ/kg °C	BTU/lb °F

Wiring and Connection for Enthalpy Pre-Configuration

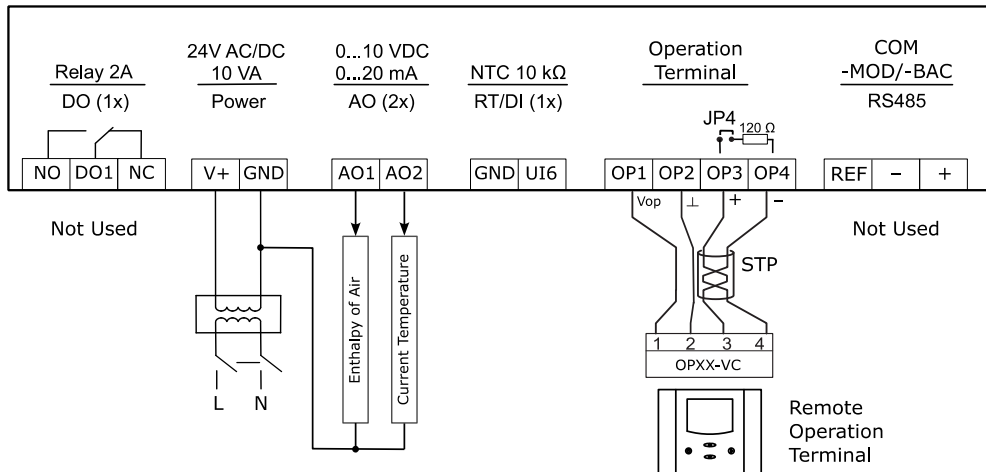

Operation and Configuration

Documentation

This controller uses the latest generation X2 operating system. Detailed operation instructions for all devices equipped with this operating system can be found on our website www.vectorcontrols.com. Also available are programming instructions for technicians and an application database.



More information on the X2 operating system can be found on our website www.vectorcontrols.com under "X2 Controls".

Configuration

Configuring with EasySet (free PC application)

We recommend to use the PC and the EasySet tool to easily configure the SDC2 to your needs. Connect the PC with the EasySet tool via the AEC-USB converter or use the PC's Wi-Fi communication to connect to the SDC2 (SDC2-WIM /-WIB types only). Refer to the SDC2 installation sheet for connection details and the X2 Engineering Manual for configuration details.



The device can be fully configured and commissioned using the EasySet program. EasySet may be downloaded free of charge from our website www.vectorcontrols.com.

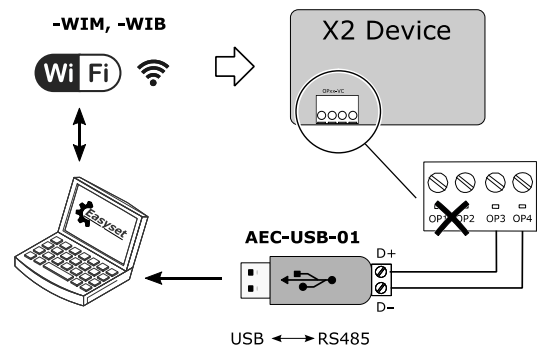

Configuring with operation terminal

Alternatively, the SDC2 can also be configured via an external operation terminal (OPT1-xx, OPA2-xx) to your needs. Connect the terminal to the OPxx-VC connectors on the SDC2. Refer to the SDC2 installation sheet and the X2 Engineering Manual for configuration details.



For more information on configuration, refer to the X2 Engineering Manual, document no. 70-00-0737.

Copy configuration to other SDC2 devices

Complete parameter sets may be copied using the accessory AEC-PM2 or exchanged with a PC using the EasySet tool and an RS485-USB converter or via Wi-Fi communication.

Copy configuration with the AEC-PM2 (plug-in memory)

To load the configuration into the AEC-PM2, we recommend using the EasySet "Copy Memory" function. Alternatively, an external operation terminal can be used to instruct the SDC2 to load the configuration into the AEC-PM2 (see X2 Engineering Manual and SDC2 Installation Sheet).

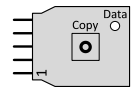

AEC-PM2

To copy the configuration to another SDC2, simply connect the AEC-PM2 plug-in memory to the SDC2 and press the copy button (see the SDC2 installation sheet for connection details).

Copy configuration with EasySet (free PC application)

To copy the configuration to another SDC2 device, connect the PC with the EasySet tool via the AEC-USB converter or use the PC's Wi-Fi communication to connect to the SDC2 (for SDC2-WIM /-WIB types only). Refer to the SDC2 installation sheet for connection details.



For more information on configuration, refer to the X2 Engineering Manual, document no. 70-00-0737.

Documentation overview

Document Type	Document No.	Description
SDC2 Data Sheet	70-00-0676	Product data sheet (this document)
SDC2-200 Install Sheet	70-00-0707	Mounting and installation manual
SDC2-210 Install Sheet	70-00-0664	Mounting and installation manual
X2 Operations Manual touch button display	70-00-0994	Operations instructions of X2 system with touch button and display
X2 Engineering Manual	70-00-0737	Guidelines for configuring the X2 system
X2 Modbus Communication Module (-MOD type)	70-00-0290	Setup and configuration manual Modbus (no Modbus TCP)
X2 BACnet Communication Module (-BAC type)	70-00-0218	Setup and configuration manual BACnet (no BACnet/IP)

Note: The above list is not complete. The documents on the website are relevant.

BACnet Protocol Implementation Conformance Statement (PICS)**BACnet MS/TP network**

 The following is only valid for products with the **-BAC** type option.

Vendor Name: Vector Controls
Product Name: SDC2 Controls series
SDC2 product description: The SDC2 communicating BACnet controllers are designed as universal controls equipment suitable for a large number of applications. They may be used in zoning and other applications which are monitored by a BACnet MS/TP network.

Supported BACnet Interoperability Blocks (BIBB)

The BACnet interface conforms to the B-ASC device profile (BACnet Application Specific Controller). The following BACnet Interoperability Building Blocks (BIBB) is supported.

BIBB	Type	Name
DS-RP-B	Data sharing	Read property - B
DS-RPM-B	Data sharing	Read property multiple - B
DS-WP-B	Data sharing	Write property - B
DM-DCC-B	Device management	Device communication Control - B
DM-DDB-B	Device management	Dynamic device binding - B
DM-DOB-B	Device management	Dynamic object binding - B
DM-TS-B	Device management	Time synchronization - B
DM-UTC-B	Device management	UTC Time synchronization - B
DM-RD-B	Device management	Reinitialize device - B

Supported standard BACnet application services

- ReadProperty
- ReadPropertyMultiple
- WriteProperty
- DeviceCommunication (password protected)
- I-Am
- I-Have
- TimeSynchronisation
- UTCTimeSynchronisation
- ReinitializeDevice ("cold" or "warm") (password protected)

Supported standard Object types

- Device
- Analog input
- Analog value
- Binary value
- Multi-state Value

X2 Functional Scope

The controller SDC2-200 has the following X2 functions and elements:

Group	Modules	QTY	Description
UP			User and display parameters
UI	01U to 05U	5	Sensor inputs for temperature, humidity, CO2 and VOC
	06U to 09U	4	Virtual inputs for operation terminals, bus modules or special functions
AL	1AL to 8AL	8	Alarm conditions
LP	1L to 2L	2	Control loops
Ao	1A	1	Analog output for mA, VDC
FAN	1F	1	Fan or lead lag modules, 1 to 3 fan speeds, up to 3 switching lead-lag stages each
do	1d	1	Binary output with a normally open and a normally closed (SPDT) relays contact
FU	1FU	1	Remote Enable: Activation of the controller based on signal and alarm conditions
	2FU	1	Change Operation Mode: Switching occupied and unoccupied with control signals
	3FU	1	Heat/Cool Change: Switching heating and cooling based on a control signal
	4FU	1	Setpoint Compensation: Summer/winter compensation of setpoint
	5FU	1	Economizer (free heating or cooling due to the condition of outside and room air)
Co			Communication (if a communication module is available)
COPY			Copying complete parameter sets between run, default and external memory with up to 4 memory locations (AEC-PM2)

The controller SDC2-210 has the following X2 functions and elements:

Group	Modules	QTY	Description
UP			User and display parameters
UI	01U to 05U	5	Sensor inputs for temperature, humidity, CO2 and VOC
	06U	1	Universal input for RT/DI
	07U to 10U	4	Virtual inputs for operation terminals, bus modules or special functions
AL	1AL to 8AL	8	Alarm conditions
LP	1L to 2L	2	Control loops
Ao	1A to 2A	2	Analog outputs for mA, VDC
FAN	1F	1	Fan or lead lag modules, 1 to 3 fan speeds, up to 3 switching lead-lag stages each
do	1d	1	Binary output with a normally open and a normally closed (SPDT) relays contact
FU	1FU	1	Remote Enable: Activation of the controller based on signal and alarm conditions
	2FU	1	Change Operation Mode: Switching occupied and unoccupied with control signals
	3FU	1	Heat/Cool Change: Switching heating and cooling based on a control signal
	4FU	1	Setpoint Compensation: Summer/winter compensation of setpoint
	5FU	1	Economizer (free heating or cooling due to the condition of outside and room air)
Co			Communication (if a communication module is available)
COPY			Copying complete parameter sets between run, default and external memory with up to 4 memory locations (AEC-PM2)

Operation manual and configuration

This controller uses the latest generation X2 operating system. Detailed operating instructions for all devices equipped with this operating system can be downloaded here: www.vectorcontrols.com/products/x2
Also available are programming instructions for technicians and an application database.

The device can be fully configured using EasySet.

EasySet may be downloaded free of charge from www.vectorcontrols.com.

Empty Page

Smart Sensors and Controls Made Easy!

Quality - Innovation – Partnership

Vector Controls GmbH
Switzerland

info@vectorcontrols.com
www.vectorcontrols.com

